

A-ONE 工具系统(二)

--用于电火花成型，工模具制造

深圳市精钻智能制造有限公司

地址: 深圳市光明区马田街道石围社区大田洋工业区1号A栋101

电话: 86-755-27296210 27296211 27296212

传真: 86-755-27296213

Q Q: 2850995008

全国服务热线: 400-880-9912

ShenZhen JingZuan Intelligent Manufacturing CO.,LTD

Add: No.101, Building A, Shiwei Datianyang Industrial Area, Matian Ave, Guangming Area, Shenzhen

TEL: 86-755-27296210 27296211 27296212

FAX: 86-755-27296213

Q Q: 2850995008

Hotline: +86 400-880-9912

苏州市精钻智能制造有限责任公司

SuZhou Jingzuan Intelligent Manufacturing Co.,LTD

苏州市相城区望亭镇何家角村杭桥路3号

ADD: No.3, Hangqiao Road, Hejiajiao Village, Wangting Town, Xiangcheng Area, Suzhou

电话 (TEL): 0512-6575 1221

传真 (FAX): 0512-6575 1222



A-ONE中文网站



A-ONE英文网站

Folio: 210mm*285mm 1/16

Sheets: 1.25 2 inset

Revision: 2022-06 first printing

Printing: 0-5000

Code: SZJZ - 3A 02-110

★ Final interpretation of all contents, text in the picture and text are for reference only, actual product, subject to change without notice. Please call +86 755 27296210/6211/6212.

★ 本画册最终解释权归本公司所有, 文中图片及文字仅供参考, 产品以实物为准, 如有变更, 恕不另行通知, 详情请致电 0755-27296210/6211/6212

★ 版权所有 翻版必究

E-mail: zgx@szjztools.com

Http://www.szjztools.com

Http://www.system3a.com



A-ONE 

公司简介

深圳市精钻智能制造有限公司自2000年成立以来，秉承“精益求精，钻石服务”的经营理念，不断引进先进的设备及技术，生产高品质、稳定可靠的产品，为客户创造更多价值。现有牧野（MAKINO）、哈斯（HAAS）数控加工中心；大隈（OKUMA）数控车床，琼格（JUNG）数控成型磨床、克林伯格（KELLENBERGER-100）数控内外圆磨床、摩尔（MOORE）坐标磨床及蔡司（ZEISS）三次元等先进的制造设备及检测仪器，经过20年多年的技术沉淀及经验积累，已发展成具有一定规模的生产企业。

公司主要生产：零点快换夹具系列；电极制造夹具系列；自定心虎钳及燕尾槽夹具系列；夹头、导套等轴类产品系列，广泛应用于模具电极制造和零件加工领域，适用于加工中心、数控车床、电火花机、线切割等设备，凭借产品丰富、品质稳定、价格合理，赢得客户的信赖与支持，产品远销美国、俄罗斯、德国、瑞士、意大利、法国、西班牙、以色列、日本、韩国等国家。

并于2022年苏州生产基地正式竣工投产，使用面积达25000平方米，为高品质、批量化生产提供强有力保证，并承接非标夹具设计、精密零件及OEM委托制造服务，助您开创事业新版图。

精钻公司始终坚持：为企业及行业发展有所贡献而奋斗，我们以此为目标，专注行业发展，洞察客户需求，综合综效，以双赢思维服务好每一位客户。

Company profile

Since its establishment in 2000, Shenzhen Jingzuan Intelligent Manufacturing Co., Ltd. has been adhering to the business philosophy of "Keep Improving, Diamond Service", constantly introducing advanced equipment and technology, producing high-quality, stable and reliable products, and creating more value for customers. The company currently has MAKINO and HAAS CNC machining centers; OKUMA CNC lathes, JUNG CNC forming grinders, KELLENBERGER-100 CNC internal and external cylindrical grinders, MOORE coordinate grinder, ZEISS three-dimensional, other advanced manufacturing equipment and testing instruments. After more than 20 years of technical precipitation and experience accumulation, it has developed into a certain scale of production enterprises.

The company mainly produces: zero-point quick change fixture series; electrode manufacturing fixture series; self-centering vise and dovetail fixture series; shaft product series such as collet chuck and guide sleeves, which are widely used in the field of mold electrode manufacturing and parts processing, suitable for machining centers, CNC lathes, EDM machines, wire cutting and other equipment. With rich products, stable quality and reasonable prices, it has won the trust and support of customers. The products are exported to the United States, Russia, Germany, Switzerland, Italy, France, Spain, Israel, Japan, South Korea and other countries.

The Suzhou production base will be completed and put into operation in 2022, with an area of 25,000 square meters, providing a strong guarantee for high-quality, mass production, and undertaking non-standard fixture design, precision parts and OEM commissioned manufacturing services to help you create a new business map.

Jingzuan Company always insists: strive to contribute to the development of the enterprise and the industry. We take this as the goal, focus on industry development, insight into customer needs, integrate comprehensive results, and serve every customer with a win-win thinking.



苏州工厂



深圳工厂

- A-ONE快速定位夹具系统使用简单，将柔性和刚性完美结合。通过客户长期使用，一起见证A-ONE快速定位夹具在使用中体现：耐用、稳定、可靠。
- 标准化的接口—实现铣削、钻削、车削、磨削、电火花成型、线切割机床以及测量和预调台高效转换，确保加工品质，提高生产效率。

- A-ONE fast positioning fixture system is easy to use and makes perfect combination of flexibility and rigidity. Through the long-term use of customers, we will witness the A-ONE quick positioning fixture in use: durable, stable and reliable.
- Standardized interfaces – highly efficient conversion among the milling, drilling, turning, grinding, EDM shaping, linear cutting machine, measuring and presetting station, which can ensure machining quality and improve the production efficiency.



苏州生产车间

SUZHOU PRODUCTION WORKSHOP



制造设备 Manufacturing facilities

为满足客户大工件生产需求，精钻苏州工厂投资购置：大行程生产设备及检测仪器，如：大隈龙门加工中心，轴向行程：2000*1600*450、牧野数控卧式加工中心，轴向行程：1520*1250*1350，X、Y、Z轴光栅反馈0.1μm，冈本精密平面磨床及海克斯康三坐标测量仪

In order to meet the needs of customers for the production of large workpieces, JingZuan Suzhou factory invested and purchased: large-travel production equipment and testing instruments, such as: Okuma Machining Center, axial stroke: 2000*1600*450, Makino CNC horizontal machining center, axial stroke: 1520*1250*1350, X, Y, Z axis grating feedback 0.1μm, Okamoto precision surface grinder and Hexagon three-coordinate testing equipment.

MAKINO 牧野卧式加工中心 a92 轴向行程：1520*1250*1350
X、Y、Z轴光栅反馈0.1μm

MAKINO 牧野卧式加工中心 a81NX 轴向行程：900*900*1020，X、Y、Z轴光栅反馈0.05μm

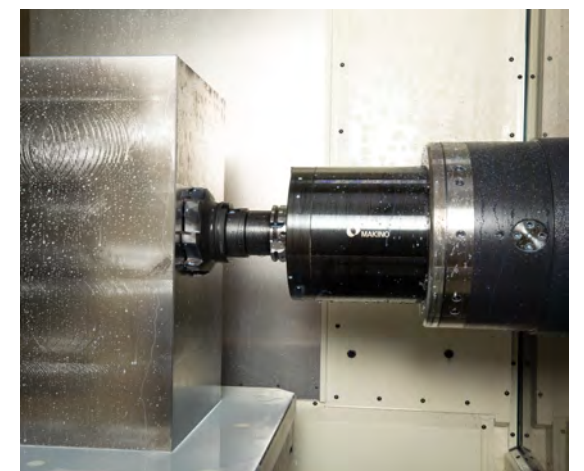

苏州生产车间

SUZHOU PRODUCTION WORKSHOP



OKUMA 大隈龙门加工中心 MCV-AII16*20 轴向行程: 2000*1600*450



OKAMOTO 冈本平面磨床 ACC105GX 工作台行程: 1150*540

苏州检测室

SUZHOU TESTING WORKSHOP



HEXAGON 海克斯康三坐标测量仪 SAGER 06.08.06
行程范围: 600*800*600, 长度测量误差: $E_0=0.6+L/400\mu\text{m}$, 重复精度: 0.5 μm



HEXAGON 海克斯康三坐标测量仪 Inspector Classic 12.22.10 行程范围: 1200*2200*1000

深圳生产车间

SHENZHEN PRODUCTION WORKSHOP



MAKINO加工中心 MAKINO Machining center



柔性生产线 Flexible production line

完整的、先进的生产加工设备、专职的技术人员及严格的生产工艺管控，保证了产品的交货期及配合客户应急的快速生产。

Complete, first-class processing equipment, professional technician and excellent manufacturing technique control, to ensure the product delivery and coordinate with emergency fasten manufacture as customer request.



OKUMA CNC 精加工 OKUMA CNC Precise machining



OKUMA 车床 OKUMA Lathe

深圳生产车间

SHENZHEN PRODUCTION WORKSHOP

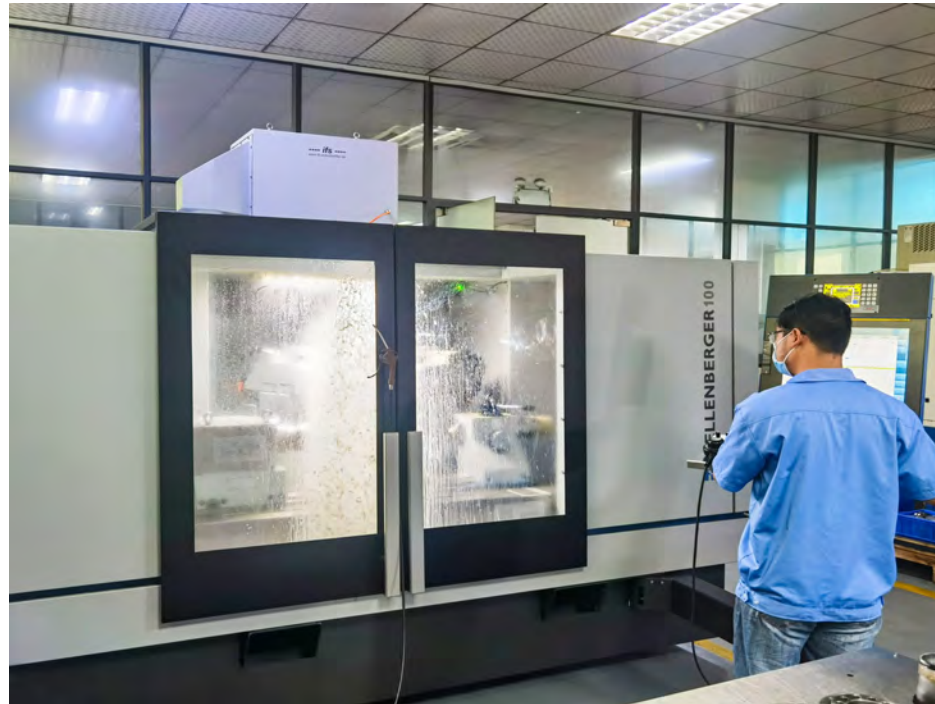

多达10种砂轮头架配置形式，所有砂轮头架均可进行直线或角向切入磨削，适用于外圆，内孔和端面磨削。控制系统的扩展软件，用于磨削标准非圆轮廓，例如：矩形，多边形，偏心圆，椭圆，半圆棒，扁平面等常见非圆轮廓。也用于磨削三棱形刀柄（COROMANT Capto），可进行圆周轮廓修正

Software extension on machine control. Simple program creation on machine control for grinding of standard non-circular contours such as Rectangle, Polygon, Eccentric, Ellipse, Rounded Bar, Flattening Subsequent Bar, Subsequent Square. Forms for polygon toolholders (COROMANT CAPTO) including extensive correction possibilities.

KELLENBERGER 100 — 完美的数控万能内外圆磨床
Perfect CNC universal inner and outer cylindrical grinding machine



MOORE 坐标磨车间 MOORE Coordinate grinding

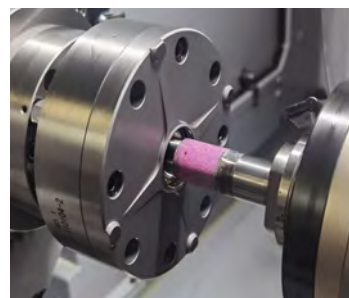

斯图特内外圆磨 STUDER Internal and external grinding



JUNG 琼格磨床 JUNG Grinding machine

专业 可靠 耐用 精密
 professional reliable durable precision



瑞士TESA测高仪
 Swiss TESA height indicator



瑞士TESA测高仪
 Swiss TESA height indicator

优良的品质保证 Excellent quality

公司全面推行ISO90001质量管理体系，并拥有德国ZEISS三坐标测量仪，ZEISS工具显微镜等检测设备，所有产品全检出货，为生产高精密的产品提供了强有力的保证。

We carried out the ISO90001 quality management system. The ZEISS coordinate measuring machine, ZEISS tool microscope and other advanced measuring equipment. All products are fully inspected to ensure the high precision.



ZEISS三坐标测量仪检测
 3A-110004零点卡盘
 ZEISS coordinate measuring machine detects Zero Point Chuck 3A-110004



ZEISS三坐标测量仪检测
 3A-200002旋转摆动式虎钳
 ZEISS coordinate measuring machine detects Rotatable Pendulum Vise 3A-200002



ZEISS三坐标测量仪检测
 ITS卡盘
 ZEISS coordinate measuring machine detects ITS Chuck



德国蔡司工具显微镜
 ZEISS tool microscope



万能工具显微镜
 ZEISS universal tool-measuring microscope

















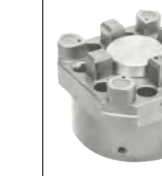









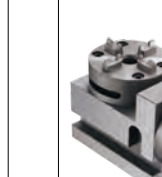





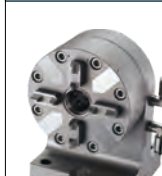



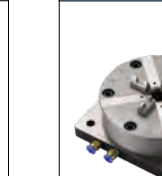
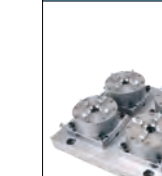
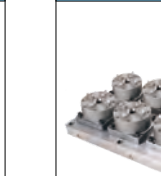

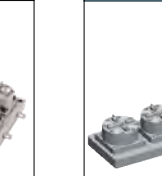
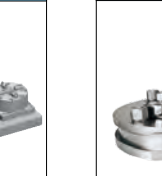































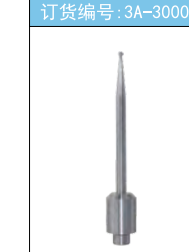









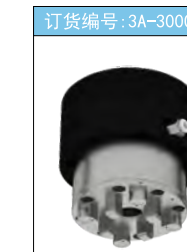



NIKON V-16A投影仪
 NIKON V-16A Projector













































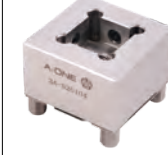





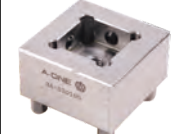















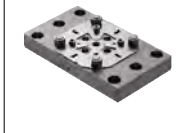









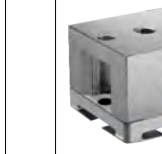

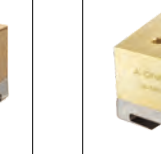

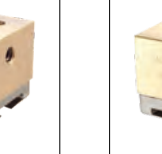









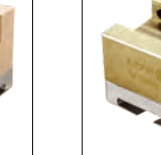
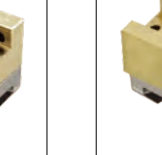











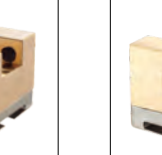



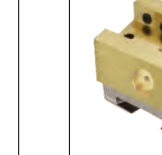

洛氏硬度计
 Rockwell hardness

ZEISS三坐标测量仪
 ZEISS coordinate measuring machine

订货编号: 3A-100001  页码:005	订货编号: 3A-100002  页码:005	订货编号: 3A-100003  页码:010	订货编号: 3A-100004  页码:011	订货编号: 3A-100005  页码:009	订货编号: 3A-100006/36  页码:009	订货编号: 3A-100070  页码:064	订货编号: 3A-100073  页码:065	订货编号: 3A-100075  页码:084	订货编号: 3A-100076  页码:066	订货编号: 3A-100077  页码:074	订货编号: 3A-100901  页码:006
订货编号: 3A-100007  页码:011	订货编号: 3A-100009  页码:010	订货编号: 3A-100011  页码:057	订货编号: 3A-100013  页码:057	订货编号: 3A-100019  页码:011	订货编号: 3A-100027  页码:012	订货编号: 3A-100902  页码:006	订货编号: 3A-100903  页码:065	订货编号: 3A-100904  页码:007	订货编号: 3A-100905  页码:016	订货编号: 3A-100923  页码:013	订货编号: 3A-100924  页码:015
订货编号: 3A-100028  页码:012	订货编号: 3A-100034  页码:012	订货编号: 3A-100031  页码:058	订货编号: 3A-100035  页码:07	订货编号: 3A-100039  页码:005	订货编号: 3A-100049/50  页码:008	订货编号: 3A-100925  页码:014	订货编号: 3A-100926  页码:014	订货编号: 3A-110927  页码:015	订货编号: 3A-110928  页码:016	订货编号: 3A-110018  页码:039	订货编号: 3A-110023  页码:037
订货编号: 3A-100051  页码:006	订货编号: 3A-100055  页码:017	订货编号: 3A-100056  页码:084	订货编号: 3A-100057  页码:007	订货编号: 3A-100061  页码:064	订货编号: 3A-100062  页码:064	订货编号: 3A-110025  页码:037	订货编号: 3A-110026  页码:038	订货编号: 3A-110027  页码:037	订货编号: 3A-110028  页码:038	订货编号: 3A-110029  页码:038	订货编号: 3A-110031  页码:038
订货编号: 3A-100063  页码:066	订货编号: 3A-100064  页码:067	订货编号: 3A-100065  页码:067	订货编号: 3A-100066  页码:068	订货编号: 3A-100067  页码:068	订货编号: 3A-100069  页码:013	订货编号: 3A-110037  页码:037	订货编号: 3A-110048  页码:039	订货编号: 3A-110084  页码:039	订货编号: 3A-110088  页码:066	订货编号: 3A-110099  页码:069	订货编号: 3A-110201  页码:040

订货编号: 3A-110401  页码: 008	订货编号: 3A-110402  页码: 008	订货编号: 3A-200001  页码: 010	订货编号: 3A-200003  页码: 046	订货编号: 3A-200040  页码: 056	订货编号: 3A-200127  页码: 071	订货编号: 3A-300053  页码: 040	订货编号: 3A-300054  页码: 084	订货编号: 3A-300055  页码: 072	订货编号: 3A-300056  页码: 056	订货编号: 3A-300058  页码: 045	订货编号: 3A-300059  页码: 072
订货编号: 3A-300001  页码: 039	订货编号: 3A-300002  页码: 040	订货编号: 3A-300003  页码: 057	订货编号: 3A-300004  页码: 045	订货编号: 3A-300005  页码: 056	订货编号: 3A-300007  页码: 056	订货编号: 3A-300057  页码: 051	订货编号: 3A-300075  页码: 053	订货编号: 3A-300076/78  页码: 053	订货编号: 3A-300077  页码: 053	订货编号: 3A-300079  页码: 052	订货编号: 3A-300080  页码: 052
订货编号: 3A-300008  页码: 046	订货编号: 3A-300010  页码: 046	订货编号: 3A-300013  页码: 050	订货编号: 3A-300016  页码: 045	订货编号: 3A-300017  页码: 047	订货编号: 3A-300018  页码: 047	订货编号: 3A-300081  页码: 052	订货编号: 3A-300083  页码: 051	订货编号: 3A-300090  页码: 058	订货编号: 3A-300093  页码: 048	订货编号: 3A-300095  页码: 070	订货编号: 3A-300099  页码: 085
订货编号: 3A-300019  页码: 058	订货编号: 3A-300022  页码: 040	订货编号: 3A-300025  页码: 035	订货编号: 3A-300027  页码: 084	订货编号: 3A-300036  页码: 049	订货编号: 3A-300037  页码: 050	订货编号: 3A-300102  页码: 048	订货编号: 3A-300105  页码: 070	订货编号: 3A-300106  页码: 070	订货编号: 3A-300107  页码: 036	订货编号: 3A-300117  页码: 048	订货编号: 3A-300118  页码: 071
订货编号: 3A-300042  页码: 047	订货编号: 3A-300043  页码: 047	订货编号: 3A-300048  页码: 048	订货编号: 3A-300049  页码: 072	订货编号: 3A-300050  页码: 049	订货编号: 3A-300052  页码: 040	订货编号: 3A-300150  页码: 071	订货编号: 3A-400001  页码: 021	订货编号: 3A-400002  页码: 021	订货编号: 3A-400003  页码: 021	订货编号: 3A-400006  页码: 073	订货编号: 3A-400005  页码: 042

订货编号: 3A-400007  页码: 043	订货编号: 3A-400008  页码: 073	订货编号: 3A-400009  页码: 059	订货编号: 3A-400010  页码: 042	订货编号: 3A-400013  页码: 035	订货编号: 3A-400022  页码: 035	订货编号: 3A-500116  页码: 026	订货编号: 3A-500123  页码: 026	订货编号: 3A-500124  页码: 027	订货编号: 3A-500127  页码: 027	订货编号: 3A-500128  页码: 027	订货编号: 3A-500132  页码: 027
订货编号: 3A-400021  页码: 036	订货编号: 3A-400036  页码: 057	订货编号: 3A-400038  页码: 043	订货编号: 3A-400039  页码: 043	订货编号: 3A-400043  页码: 073	订货编号: 3A-400054  页码: 035	订货编号: 3A-501100  页码: 022	订货编号: 3A-501103  页码: 022	订货编号: 3A-501104  页码: 023	订货编号: 3A-501105  页码: 023	订货编号: 3A-501108  页码: 024	订货编号: 3A-501109  页码: 024
订货编号: 3A-400079  页码: 021	订货编号: 3A-400083  页码: 042	订货编号: 3A-400084  页码: 060	订货编号: 3A-400090  页码: 073	订货编号: 3A-400096  页码: 036	订货编号: 3A-400108  页码: 074	订货编号: 3A-501110  页码: 025	订货编号: 3A-501115  页码: 025	订货编号: 3A-501116  页码: 026	订货编号: 3A-501123  页码: 026	订货编号: 3A-520103  页码: 028	订货编号: 3A-520104  页码: 028
订货编号: 3A-400141  页码: 067	订货编号: 3A-400201  页码: 059	订货编号: 3A-400202  页码: 059	订货编号: 3A-400203  页码: 059	订货编号: 3A-500100  页码: 022	订货编号: 3A-500103  页码: 022	订货编号: 3A-520105  页码: 029	订货编号: 3A-520108  页码: 029	订货编号: 3A-520109  页码: 030	订货编号: 3A-520110  页码: 030	订货编号: 3A-520115  页码: 031	订货编号: 3A-520116  页码: 031
订货编号: 3A-500104  页码: 023	订货编号: 3A-500105  页码: 023	订货编号: 3A-500108  页码: 024	订货编号: 3A-500109  页码: 024	订货编号: 3A-500110  页码: 025	订货编号: 3A-500115  页码: 025	订货编号: 3A-520117  页码: 032	订货编号: 3A-520118  页码: 032	订货编号: 3A-520119  页码: 033	订货编号: 3A-520124  页码: 033	订货编号: 3A-520131  页码: 034	订货编号: 3A-520132  页码: 034

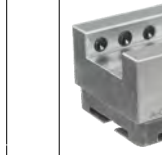
订货编号: 3A-521103  页码: 028	订货编号: 3A-521104  页码: 028	订货编号: 3A-521105  页码: 029	订货编号: 3A-521108  页码: 029	订货编号: 3A-521109  页码: 030	订货编号: 3A-521110  页码: 030	订货编号: 3A-531116  页码: 079	订货编号: 3A-531123  页码: 079	订货编号: 3A-540100  页码: 080	订货编号: 3A-540103  页码: 080	订货编号: 3A-540104  页码: 081	订货编号: 3A-540105  页码: 081
订货编号: 3A-521115  页码: 031	订货编号: 3A-521116  页码: 031	订货编号: 3A-521117  页码: 032	订货编号: 3A-521118  页码: 032	订货编号: 3A-521119  页码: 033	订货编号: 3A-520124  页码: 033	订货编号: 3A-540108  页码: 082	订货编号: 3A-540109  页码: 082	订货编号: 3A-540110  页码: 083	订货编号: 3A-540115  页码: 083	订货编号: 3A-540116  页码: 084	订货编号: 3A-540123  页码: 084
订货编号: 3A-530100  页码: 075	订货编号: 3A-530103  页码: 075	订货编号: 3A-530104  页码: 076	订货编号: 3A-530105  页码: 076	订货编号: 3A-530108  页码: 077	订货编号: 3A-530109  页码: 077	订货编号: 3A-541100  页码: 080	订货编号: 3A-541103  页码: 080	订货编号: 3A-541104  页码: 081	订货编号: 3A-541105  页码: 081	订货编号: 3A-541108  页码: 082	订货编号: 3A-541109  页码: 082
订货编号: 3A-530110  页码: 078	订货编号: 3A-530115  页码: 078	订货编号: 3A-530116  页码: 079	订货编号: 3A-530123  页码: 079	订货编号: 3A-531100  页码: 075	订货编号: 3A-531103  页码: 075	订货编号: 3A-541110  页码: 083	订货编号: 3A-541115  页码: 083	订货编号: 3A-541116  页码: 084	订货编号: 3A-541123  页码: 084	订货编号: 3A-10000349  页码: 013	
订货编号: 3A-531104  页码: 076	订货编号: 3A-531105  页码: 076	订货编号: 3A-531108  页码: 077	订货编号: 3A-531109  页码: 077	订货编号: 3A-531110  页码: 078	订货编号: 3A-531115  页码: 078						

基准卡盘及CNC夹具

Benchmark chuck and CNC jig

<http://www.szjztools.com>
<http://www.system3a.com>

最新产品信息、公司资讯等敬请浏览本公司主页

Please visit our homepage for the latest product information, company information, etc.

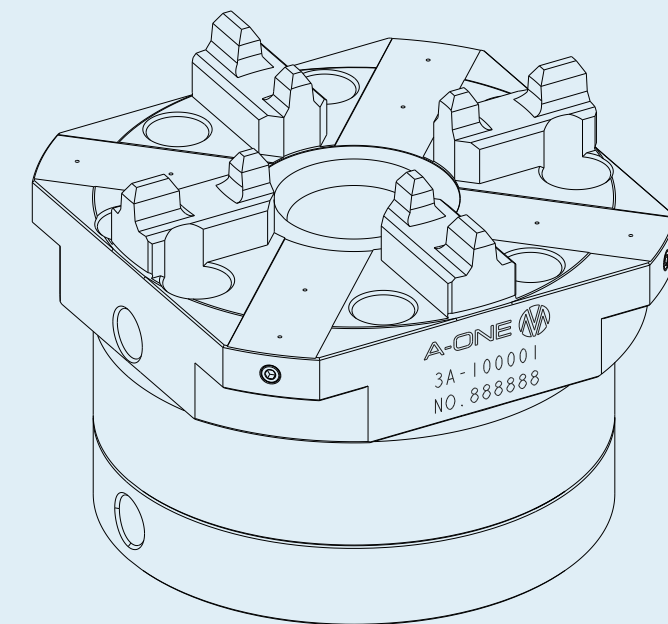

P.003~P.017

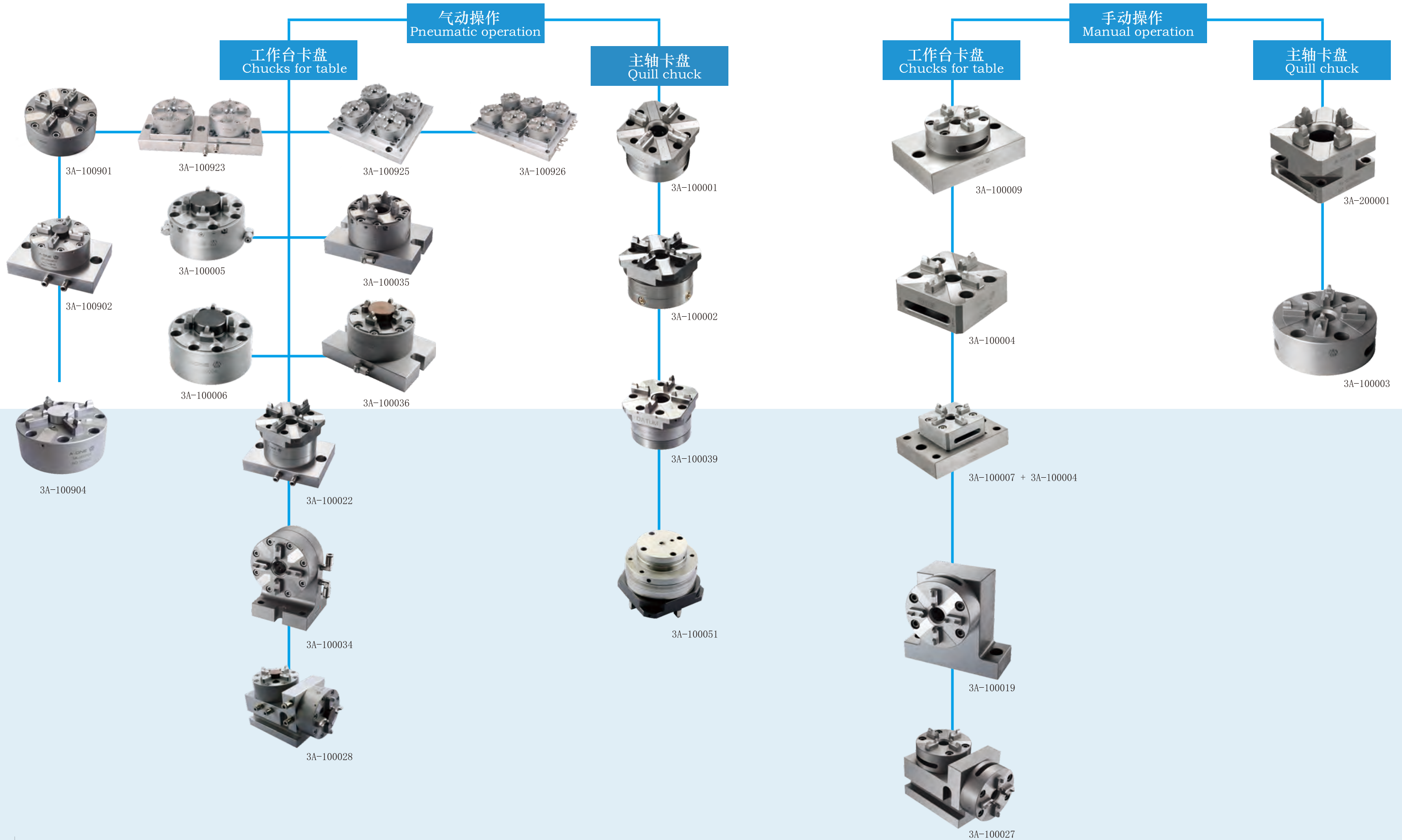

3A-100001 80型气动卡盘
Rapid-action chuck 80 automatic

- ▶ 规格 钢, 硬质
- ▶ 夹紧力 4000N
- ▶ 连接 用两条气流管路从背面
- ▶ 操作 气阀
- ▶ 应用 工作台或主轴

- ▶ Version Steel, hardened
- ▶ Clamping Power 4000N
- ▶ Connection At the rear with two lines
- ▶ Operation Air valves
- ▶ Application Used for working table or spindle

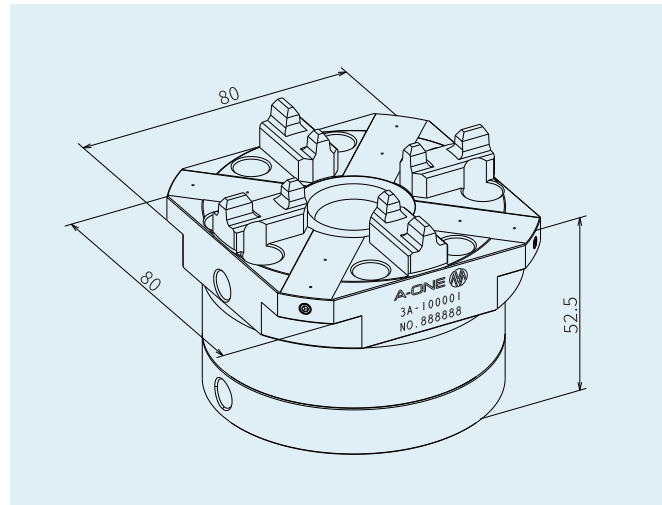

3A-100051 自动快速卡盘
Rapid-action chuck automatic

- ▶ 规格 钢, 硬质
- ▶ 夹紧力 2500N
- ▶ 连接 用两条气流管路从背面
- ▶ 操作 气阀
- ▶ 应用 用于有自动电极交换装置的电火花成型机床

- ▶ Version Steel, hardened
- ▶ Clamping Power 2500N
- ▶ Connection At the rear with two lines
- ▶ Operation Air valves
- ▶ Application EDM sinking machines with automatic electrode change

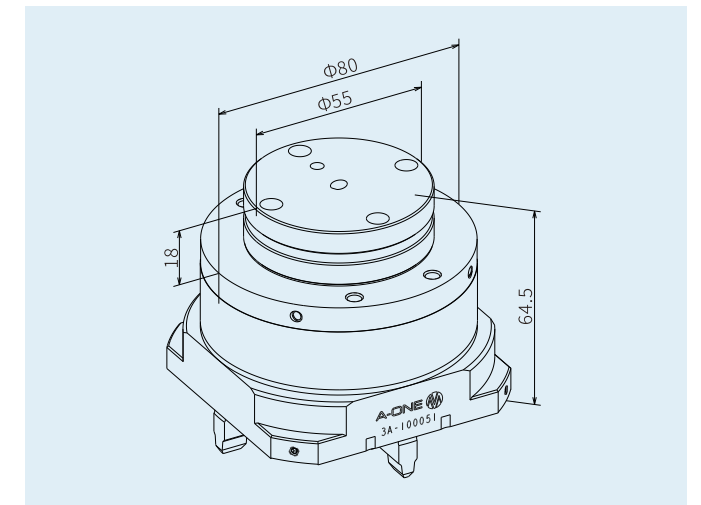

3A-100002 80型气动卡盘
Rapid-action chuck 80 automatic

- ▶ 规格 钢, 硬质
- ▶ 夹紧力 4000N
- ▶ 连接 侧面气枪操作或接气管
- ▶ 操作 气阀
- ▶ 应用 主轴或工作台、可用于车床

- ▶ Version Steel, hardened
- ▶ Clamping Power 4000N
- ▶ Connection The side air gun operation or trachea
- ▶ Operation Air valves
- ▶ Application On the machine spindle, working table or lathe

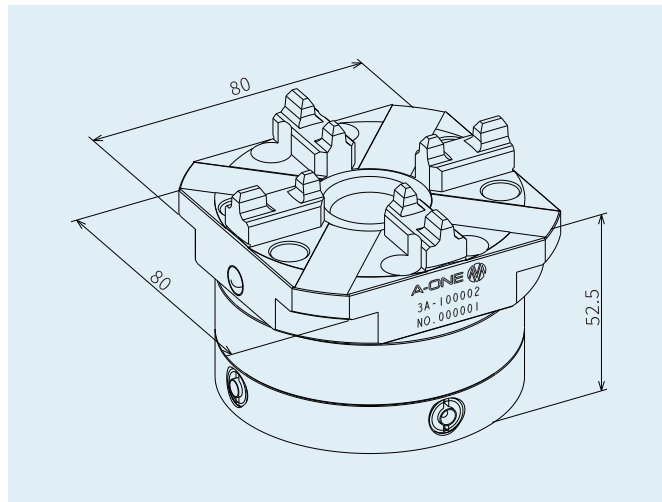

3A-100901 100型气动卡盘 (不含底板)
ITS chuck 100 p 102x102 (without plate)

- ▶ 规格 钢, 硬质
- ▶ 夹紧力 6000N
- ▶ 连接 用两条气流管路从背面
- ▶ 操作 气阀
- ▶ 应用 工作台或主轴

- ▶ Version Steel, hardened
- ▶ Clamping Power 6000N
- ▶ Connection At the rear with two lines
- ▶ Operation Air valves
- ▶ Application Used for working table or spindle

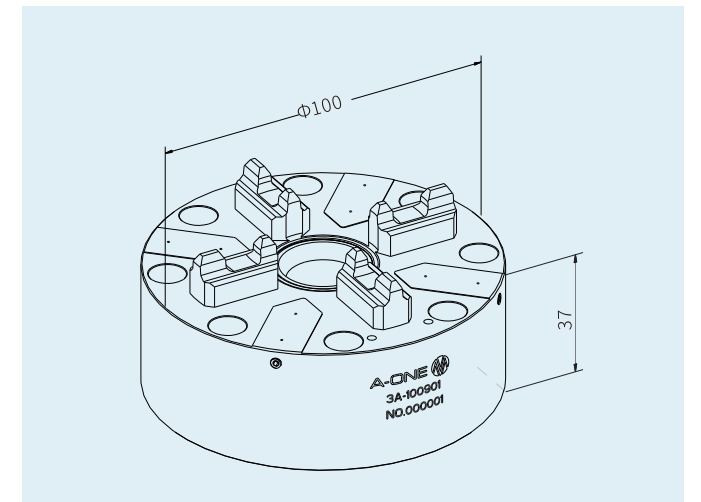

3A-100039 自动卡盘
Automatic chuck

- ▶ 规格 钢, 硬质
- ▶ 夹紧力 2500N
- ▶ 连接 用两条气流管路从背面
- ▶ 操作 气阀
- ▶ 应用 用于有自动电极交换装置的电火花成型机床、自动装料的机床和生产线

- ▶ Version Steel, hardened
- ▶ Clamping Power 2500N
- ▶ Connection At the rear with two lines
- ▶ Operation Air valves
- ▶ Application EDM sinking machines with automatic electrode change, machine tools with automatic loading, production lines

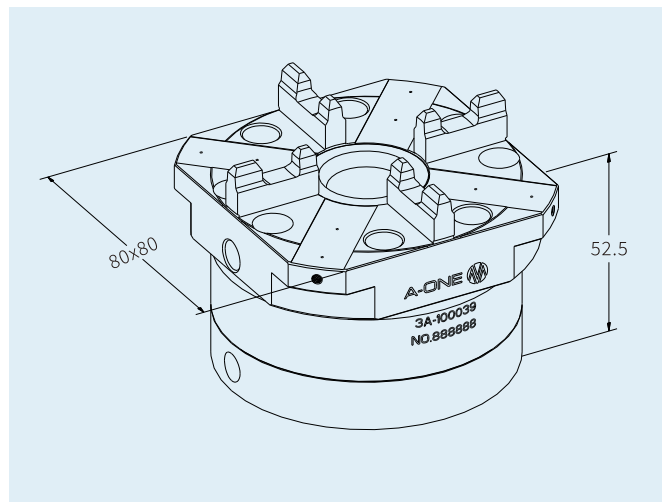

3A-100902 100型单中心气动卡盘 (含底板)
ITS chuck 100 P (with plate)

- ▶ 规格 钢, 硬质
- ▶ 夹紧力 6000N
- ▶ 连接 用两条气流管路从背面
- ▶ 操作 气阀
- ▶ 应用 工作台或主轴

- ▶ Version Steel, hardened
- ▶ Clamping Power 6000N
- ▶ Connection At the rear with two lines
- ▶ Operation Air valves
- ▶ Application Used for working table or spindle

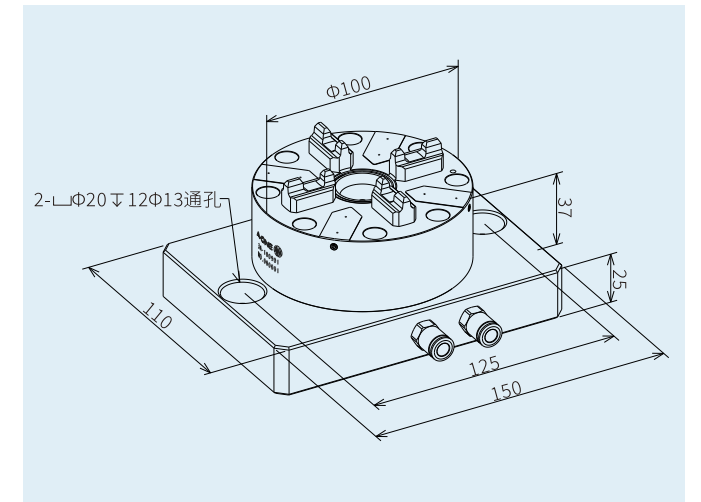

3A-100904 100型气动卡盘
Rapid-action chuck100 automatic

- ▶ 规格 不锈钢, 淬硬
- ▶ 夹紧力 6000N
- ▶ 连接 带气检、防反功能, 侧面/底面进气可选, 底面有定位精孔
- ▶ 操作 气阀
- ▶ 附图 参数(图1)
- ▶ Version Stainless steel, hardened
- ▶ Clamping Power 6000N
- ▶ Connection With air detection and anti reverse function, Side and bottom intake is available, Location hole at bottom
- ▶ Operation Air valves
- ▶ Attached diagram Parameter diagram (Figure 1)

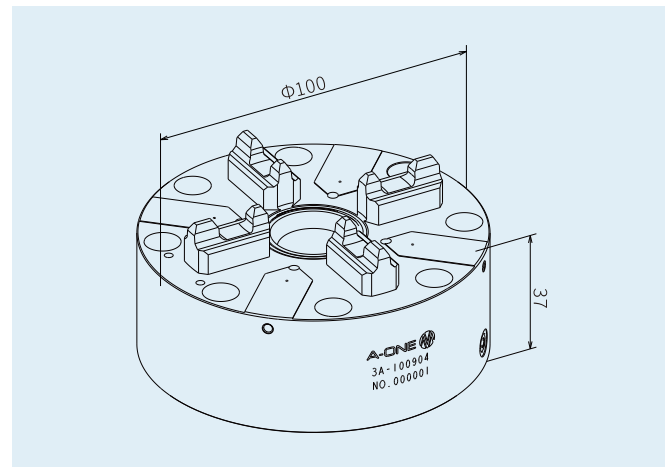

3A-100057 100型气动卡盘带底板
Rapid-action chuck100 automatic (with plate)

- ▶ 规格 不锈钢, 淬硬
- ▶ 夹紧力 6000N
- ▶ 连接 带气检、防反功能, 侧面/底面进气可选, 底面有定位精孔
- ▶ 操作 气阀
- ▶ Version Stainless steel, hardened
- ▶ Clamping Power 6000N
- ▶ Connection With air detection and anti reverse function, Side and bottom intake is available, Location hole at bottom
- ▶ Operation Air valves

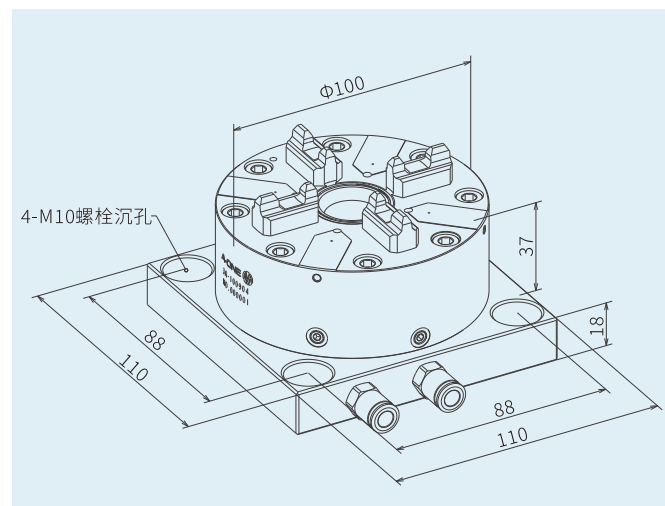

3A-100049 150强力气动卡盘
Power auto chuck 150

3A-100050 150强力气动卡盘带底板
Power auto chuck 150 (with plate)

- ▶ 规格 不锈钢, 淬硬
- ▶ 夹紧力 10000N
- ▶ 连接 侧面二线连接, 带底板, 4-M8螺丝安装过孔
- ▶ 操作 气阀
- ▶ Version Stainless steel, hardened
- ▶ Clamping Power 10000N
- ▶ Connection With 2 air tube on the side, With plate, Mounting 4-M8 screw on the plate
- ▶ Operation Air valves

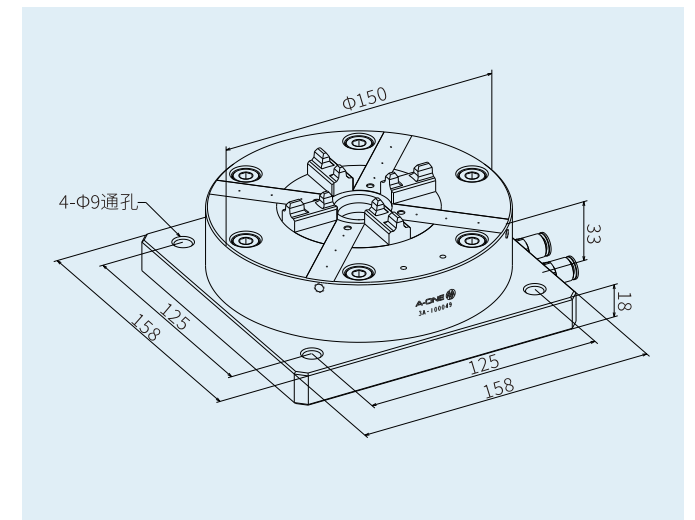

3A-110401 210卡盘
Chuck 210

- ▶ 规格 用于强力切削领域
- ▶ 连接 用两条气流管路从侧面或底部连接
- ▶ 操作 用气枪, 侧面吹气
- ▶ 应用 车床、铣床、磨床、电火花加工中心。夹持210托盘、ITSφ148托板。
- ▶ Version Used in the field of heavy cutting
- ▶ Connection From the side or bottom with two air flow lines
- ▶ Operation Blow from the side with an air gun
- ▶ Application Turning, milling, grinding and EDM machining center. Clamping pallet 210, ITS φ 148 pallet.



图1



3A-110402 210托盘
Pallet 210

- ▶ 规格 钢质, 带定位元件
- ▶ 应用 夹持工件/夹具, 配合210托盘使用
- ▶ Version Stainless steel, with centering segments
- ▶ Application Clamping workpiece/fixture, use with chuck 210

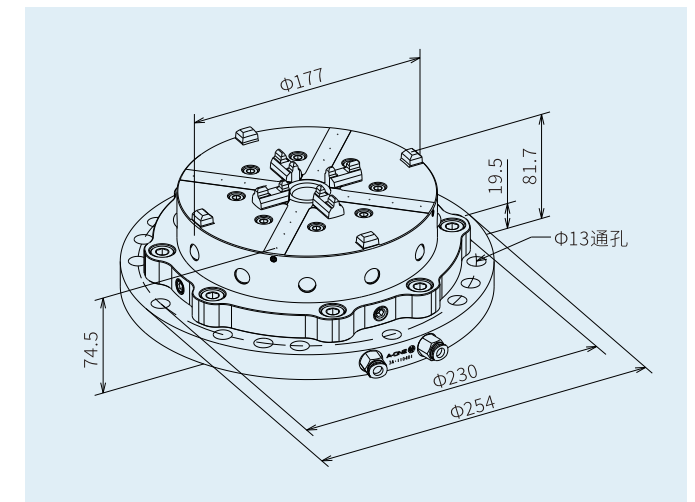
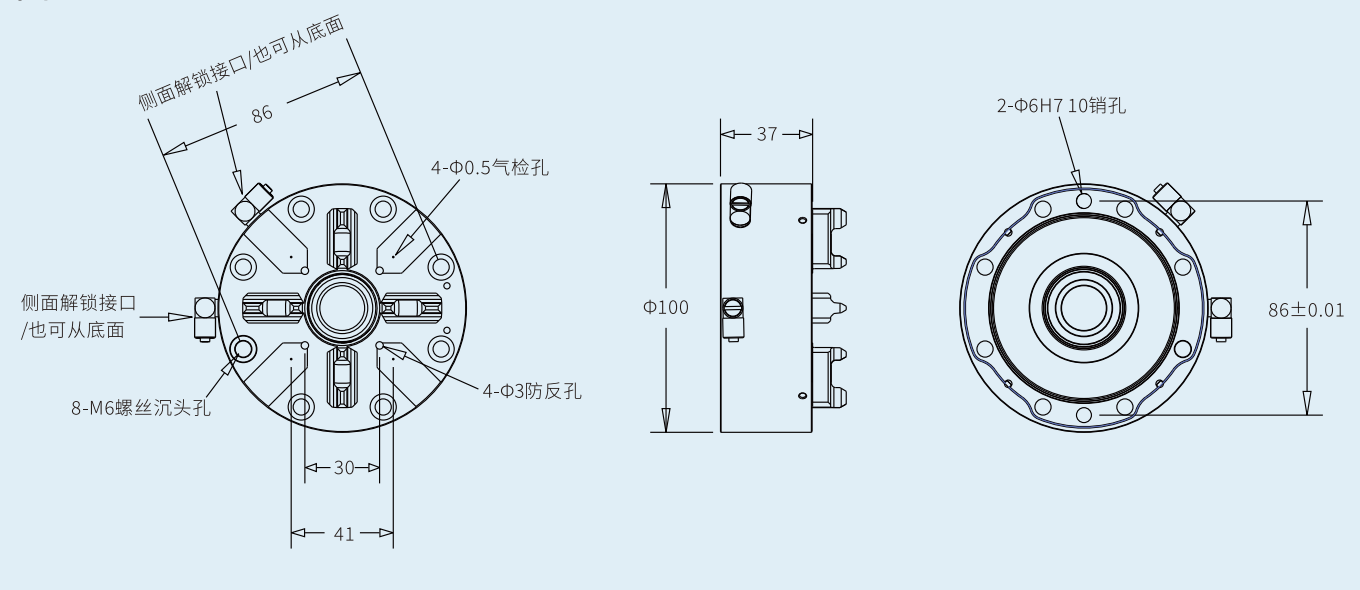
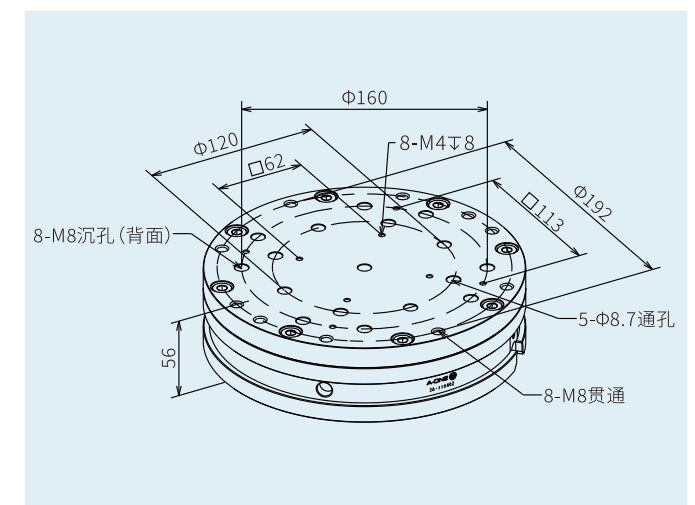

3A-100005 50型卡盘
ITS Chuck 50 Inox

- ▶ 规格 系统尺寸50, 不锈钢, 防腐蚀
 - ▶ 夹紧力 2800N
 - ▶ 连接 4-M6从背面或8个M5螺钉从正面
 - ▶ 应用 可用于客户设计的夹具
 - ▶ 注意 自动操作、气路从侧面或底部
- ▶ Version System size 50, stainless steel, corrosion-resistant
 - ▶ Clamping Power 2800N
 - ▶ Connection 4×M6 from bottom side or 8×M5 from front side
 - ▶ Application Can be used with customized tools
 - ▶ Note Automatically, on the side or at the bottom

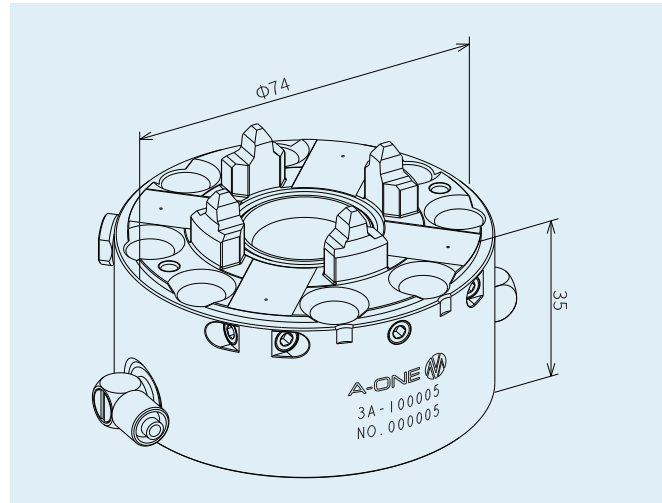

3A-200001 50型手动卡盘
Quick chuck 50

- ▶ 规格 系统尺寸 ITS 50, 手动, 防腐蚀
 - ▶ 连接 4个M8螺钉从背面或4个M6带螺母的柱头螺钉
 - ▶ 应用 在电火花机/线切割机床上装夹精铣和磨过的工件
 - ▶ 注意 夹紧力高达4000N
- ▶ Version System size ITS 50, manual, corrosion resistant
 - ▶ Connection 4×M8 from the rear or 4×M6 stud bolts with nuts
 - ▶ Application On EDM/WEDM centers for light milling and grinding workpiece
 - ▶ Note Clamping power up to 4000N

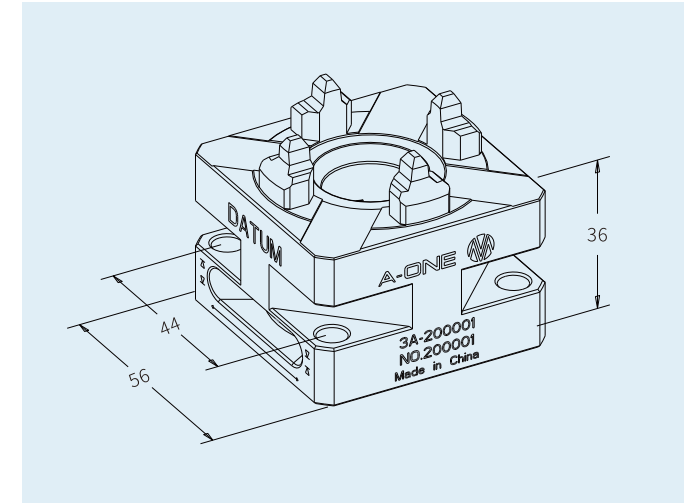

3A-100035 50型卡盘带底板
ITS Chuck 50 Inox with base plate

- ▶ 规格 系统尺寸50, 不锈钢, 防腐蚀
 - ▶ 夹紧力 2800N
 - ▶ 连接 4-M6从背面或8个M5螺钉从正面
 - ▶ 应用 可用于客户设计的夹具
 - ▶ 注意 自动操作、气路从侧面或底部
- ▶ Version System size 50, stainless steel, corrosion-resistant
 - ▶ Clamping Power 2800N
 - ▶ Connection 4×M6 from bottom side or 8×M5 from front side
 - ▶ Application Can be used with customized tools
 - ▶ Note Automatically, on the side or at the bottom

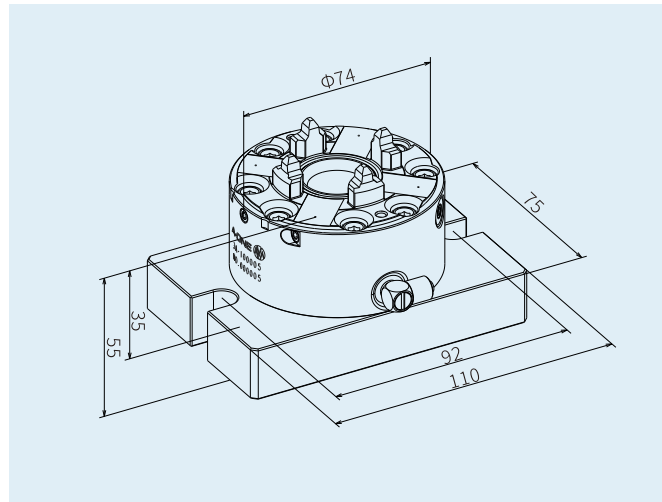

3A-100003 圆形手动卡盘
Quick chuck 100 P

- ▶ 规格 系统尺寸100, 手动, 防腐蚀
 - ▶ 夹紧力 10000N
 - ▶ 安装 用所附的4个M8螺钉
 - ▶ 应用 车床、铣床、磨床、电火花或线切割机
- ▶ Version System size 100, manual, corrosion-resistant
 - ▶ Clamping Power 10000 N
 - ▶ Mounting With four M8 bolts supplied
 - ▶ Application Turning, milling, grinding or EDM/WEDM machines, in dividers and fixtures

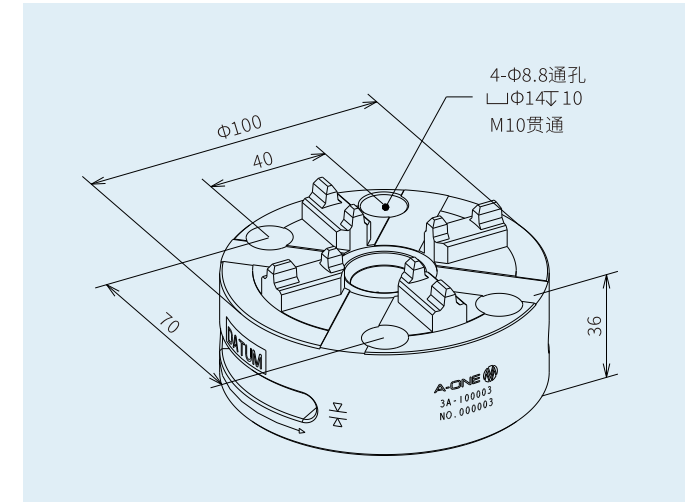

3A-100006 50型简易卡盘
ITS simple chuck 50

3A-100036 50型简易卡盘带底板
ITS simple chuck50 (with plate)

- ▶ 规格 系统尺寸50, 不锈钢, 防腐蚀, 带底板
 - ▶ 夹紧力 2800N
 - ▶ 连接 4-M6从背面或8个M5螺钉从正面
 - ▶ 应用 可用于客户设计的夹具
 - ▶ 注意 卡盘可以手动或自动操作、侧面进气
- ▶ Version System size 50, stainless steel, corrosion-resistant, with plate
 - ▶ Clamping Power 2800N
 - ▶ Connection 4×M6 from bottom side or 8×M5 from front side
 - ▶ Application Can be used with customized tools
 - ▶ Note Automatically or manually, on the side

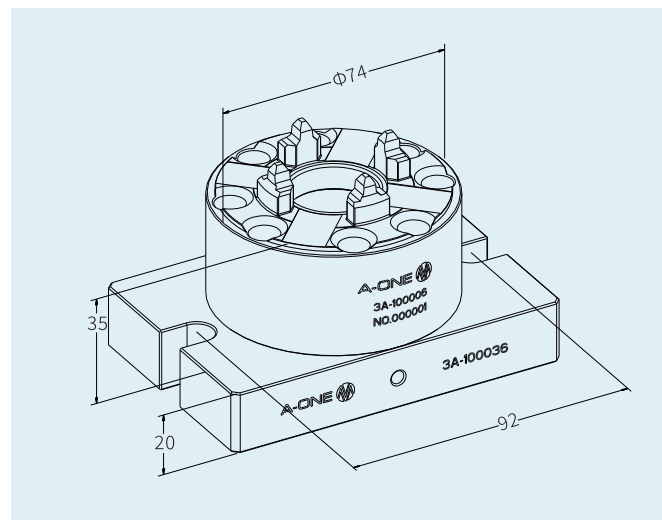

3A-100009 手动单中心卡盘
Quick chuck 100 P with base plate

- ▶ 规格 防腐蚀, 带底板
 - ▶ 夹紧力 10000N
 - ▶ 安装 用螺丝或压板
 - ▶ 应用 CNC加工中心用, 亦可用在铣床、磨床
- ▶ Version Corrosion-resistant, with plate.
 - ▶ Clamping Power 10000N
 - ▶ Mounting With bolts or plate
 - ▶ Application To be used on CNC lathe, Milling or grinding machine

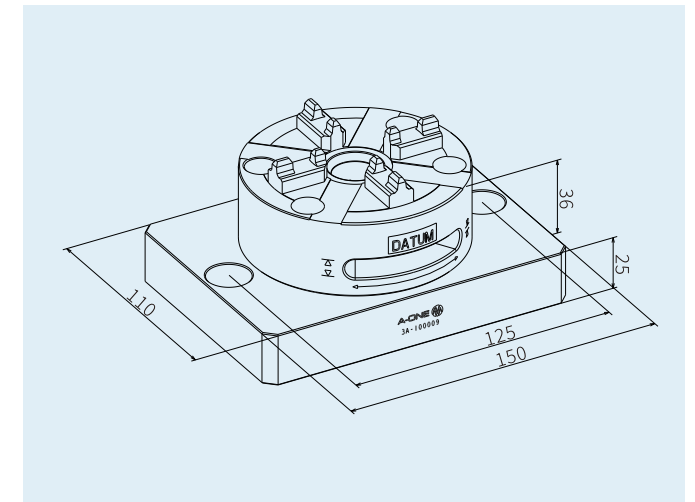

3A-100004 方型手动卡盘
Square manual chuck

- ▶ 规格 系统尺寸 90, 手动, 防腐蚀
- ▶ 夹紧力 10000N
- ▶ 安装 用所附的 4个M8螺钉
- ▶ 应用 车床、铣床、磨床、电火花或线切割机床
- ▶ Version System size 90, manual, corrosion-resistant
- ▶ Clamping Power 10000 N
- ▶ Mounting With four M8 bolts supplied
- ▶ Application Turning, milling, grinding or EDM/WEDM machines, in dividers and fixtures

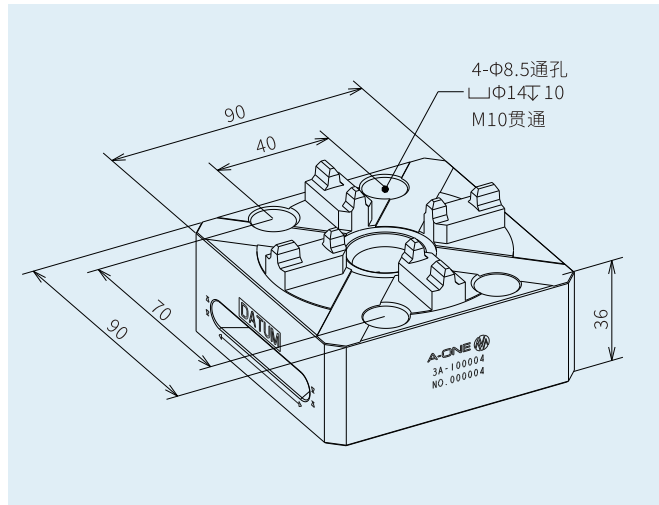

3A-100034 气动立式卡盘
Single auto chuck-horizontal

- ▶ 规格 钢, 硬质, 防腐蚀
- ▶ 安装 直接安装在工作台上
- ▶ 应用 用于CNC加工中心, 气动锁紧功能, 可侧向四面加工, 含卡盘
- ▶ Version Steel, hardened, corrosion-resistant
- ▶ Mounting To be mounted directly on the table of machining center
- ▶ Application To be used on CNC machining center, Power pneumatic lock, four sides of workpiece can be machined, with chuck

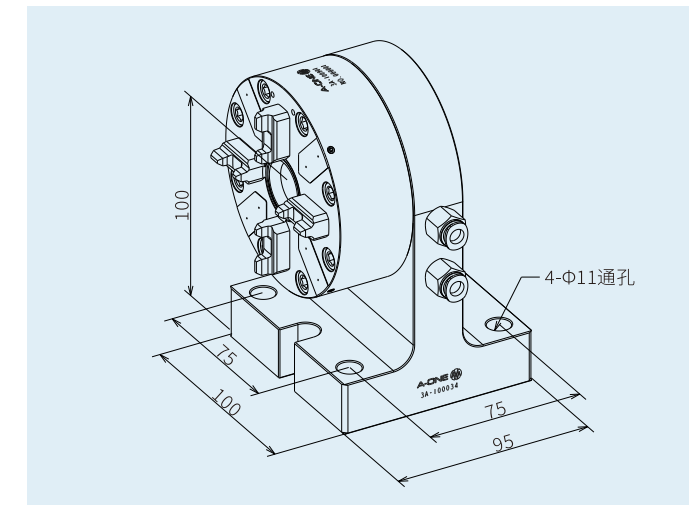

3A-100007 手动单中心卡盘底板
Base plate for single manual chuck

- ▶ 规格 手动锁紧功能, 单个基准接口, 卡盘需另购
- ▶ 连接 直接安装在工作台上
- ▶ 应用 适用于CNC、三次元检测台或其它机床
- ▶ Version Power manual lock, one air connections, manual chuck supplied separately
- ▶ Connection To be mounted directly on the table of machining center
- ▶ Application To be used on CNC lathe, coordinates measuring machine or other machines

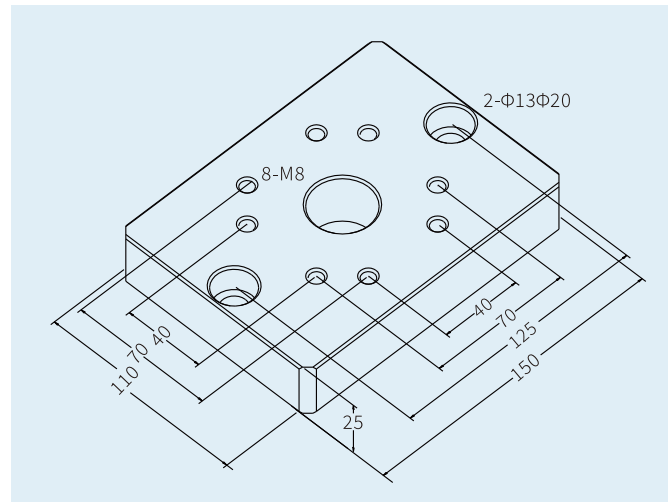

3A-100027 手动卡盘直角座
Square block for manual chuck

- ▶ 规格 钢, 硬质, 防腐蚀
- ▶ 应用 既可在水平又可在垂直位置安装1至2个3A-100003
- ▶ 注意 卡盘需另购
- ▶ Version Steel, hardened, corrosion-resistant
- ▶ Application For attaching 1 or 2 chucks 3A-100003 in horizontal and vertical position
- ▶ Note Chuck supplied separately

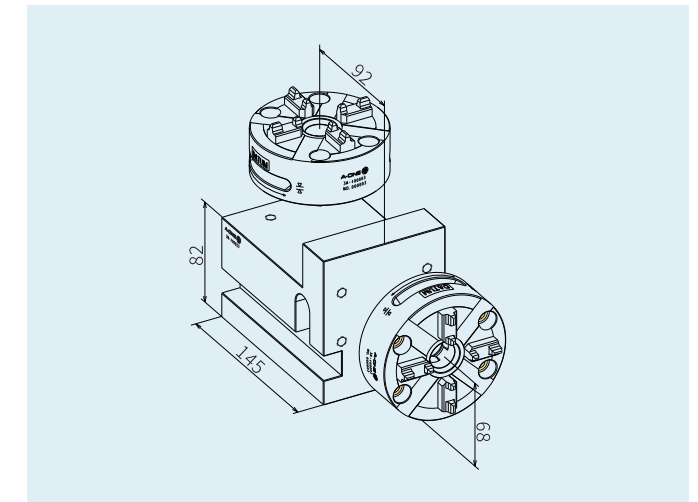

3A-100019 手动立式底座
Manual vertical base plate

- ▶ 规格 钢, 硬质, 防腐蚀
- ▶ 安装 直接安装在工作台上
- ▶ 应用 用于CNC加工中心, 手动锁紧功能, 可侧向四面加工, 卡盘需另购
- ▶ Version Steel, hardened, corrosion-resistant
- ▶ Mounting To be mounted directly on the table of machining center
- ▶ Application To be used on CNC lathe, Power manual lock, four sides of workpiece can be machined, manual chuck supplied separately

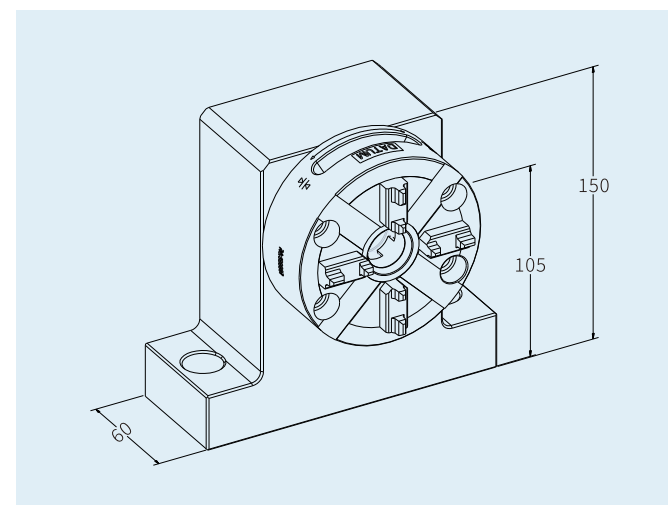

3A-100028 气动卡盘直角座
Square block for quick chuck 100P

- ▶ 规格 钢, 硬质, 防腐蚀
- ▶ 应用 既可在水平又可在垂直位置安装1至2个卡盘 3A-100901
- ▶ 注意 卡盘需另购
- ▶ Version Steel, hardened, corrosion-resistant
- ▶ Application For attaching 1 or 2 chucks 3A-100901 in horizontal and vertical position
- ▶ Note Chuck supplied separately

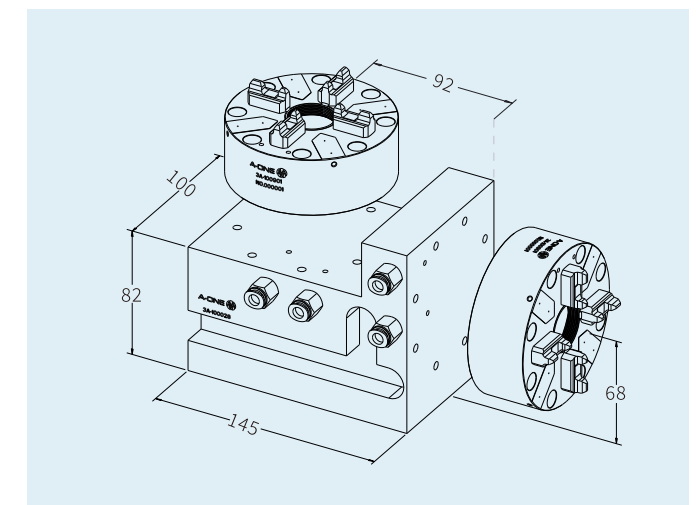

基准卡盘及CNC夹具
Benchmark chuck and CNC jig
气动、手动、工作台用
Pneumatic or manual Used on work table

3A-100069 强力气动卡盘直角座
Square block for power auto chuck

- ▶ 规格 钢, 硬质, 防腐蚀
- ▶ 应用 既可在水平又可在垂直位置安装1至2个3A-100049
- ▶ 注意 卡盘需另购
- ▶ Version Steel, hardened, corrosion-resistant
- ▶ Application For attaching 1 or 2 chucks 3A-100049 in horizontal and vertical position
- ▶ Note Chuck supplied separately

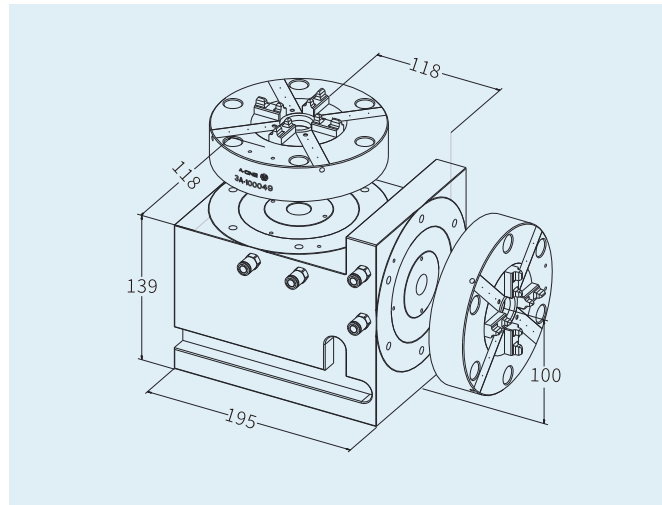

3A-100925 四中心100型气动卡盘
Auto chuck-quatro

- ▶ 规格 不锈钢, 淬硬, 气动控制0.6Mpa, 带清洁功能, 预制底板, 标准产品卡盘中心距140*120mm, 可根据客户要求订做, 价格另议
- ▶ 夹紧力 6000N
- ▶ 安装 直接安装在机床工作台上
- ▶ 应用 安装孔请参考安装说明书加工
- ▶ Version Stainless steel, hardened, pneumatic power 0.6Mpa, cleaning function, Base plate can be made in accordance Standard center to center distance 140*120mm, OEM Service available, the price is negotiable
- ▶ Clamping Power 6000N
- ▶ Mounting To be directly mounted on the table of machining center
- ▶ Application Please refer to the installation instructions for processing mounting holes

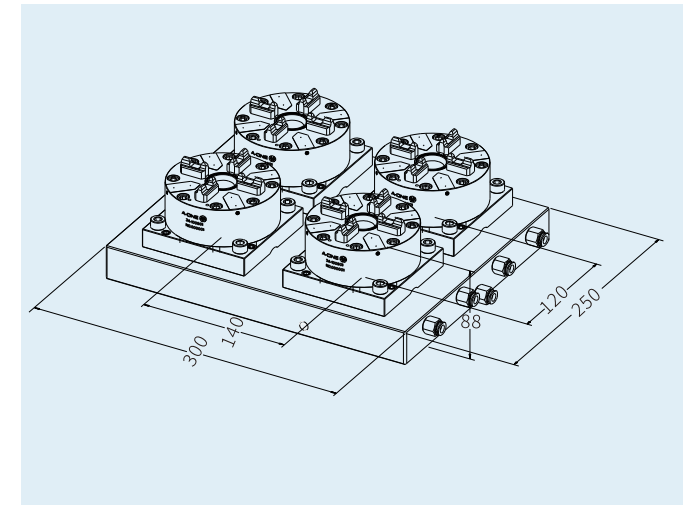

3A-10000349 强力T座
Powerful T base plate

- ▶ 规格 钢, 硬质, 防腐蚀
- ▶ 安装 直接安装在工作台上
- ▶ 应用 用于CNC加工中心, 气动锁紧功能, 可侧向四面加工, 卡盘需另购
- ▶ Version Steel, hardened, corrosion-resistant
- ▶ Mounting To be mounted directly on the table of machining center
- ▶ Application To be used on CNC machine center, Power pneumatic lock, four sides of workpiece can be machined, Chuck supplied separately

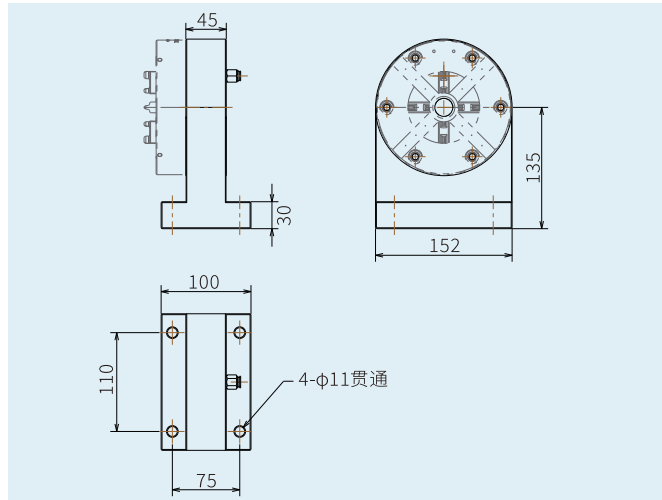

3A-100926 六中心100型气动卡盘
Auto chuck-hexa

- ▶ 规格 不锈钢, 淬硬, 气动控制0.6Mpa, 带清洁功能, 预制底板, 标准产品卡盘中心距140*120mm, 可根据客户要求订做, 价格另议
- ▶ 夹紧力 6000N
- ▶ 安装 直接安装在机床工作台上
- ▶ 应用 安装孔请参考安装说明书加工
- ▶ Version Stainless steel, hardened, pneumatic power 0.6Mpa, cleaning function, Base plate can be made in accordance Standard center to center distance 140*120mm, OEM Service available, the price is negotiable
- ▶ Clamping Power 6000N
- ▶ Mounting To be directly mounted on the table of machining center
- ▶ Application Please refer to the installation instructions for processing mounting holes

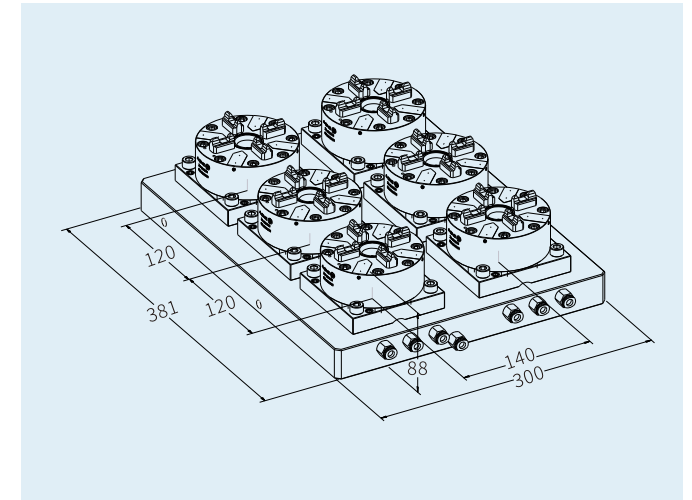

3A-100923 两中心100型气动卡盘
Auto chuck-double

- ▶ 规格 不锈钢, 淬硬, 气动控制0.6Mpa, 带清洁功能, 预制底板, 标准产品卡盘中心距140mm, 可根据客户要求订做, 价格另议
- ▶ 夹紧力 6000N
- ▶ 安装 直接安装在机床工作台上
- ▶ 应用 安装孔请参考安装说明书加工
- ▶ Version Stainless steel, hardened, pneumatic power 0.6Mpa, cleaning function, Base plate can be made in accordance Standard center to center distance 140mm, OEM Service available, the price is negotiable
- ▶ Clamping Power 6000N
- ▶ Mounting To be directly mounted on the table of machining center
- ▶ Application Please refer to the installation instructions for processing mounting holes

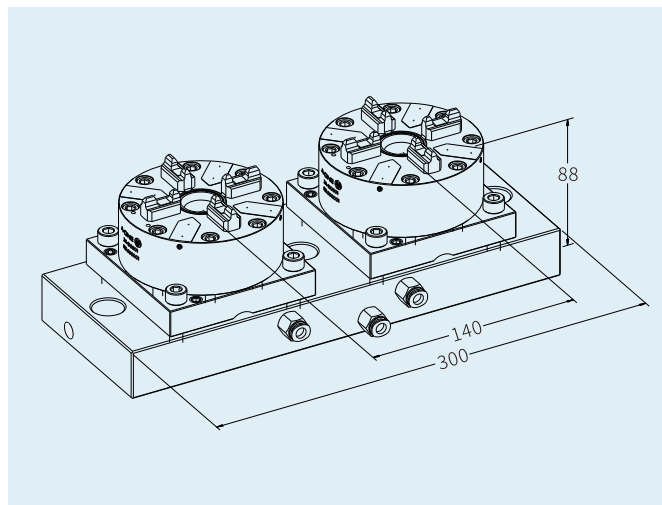

八中心100型气动卡盘
Eight-fold pneumatic chuck

- ▶ 规格 不锈钢, 淬硬, 气动控制0.6Mpa, 带清洁功能, 预制底板, 标准产品卡盘中心距140*120mm, 可根据客户要求订做, 价格另议
- ▶ 夹紧力 6000N
- ▶ 安装 直接安装在机床工作台上
- ▶ 应用 安装孔请参考安装说明书加工
- ▶ Version Stainless steel, hardened, pneumatic power 0.6Mpa, cleaning function, Base plate can be made in accordance Standard center to center distance 140*120mm, OEM Service available, the price is negotiable
- ▶ Clamping Power 6000N
- ▶ Mounting To be directly mounted on the table of machining center
- ▶ Application Please refer to the installation instructions for processing mounting holes

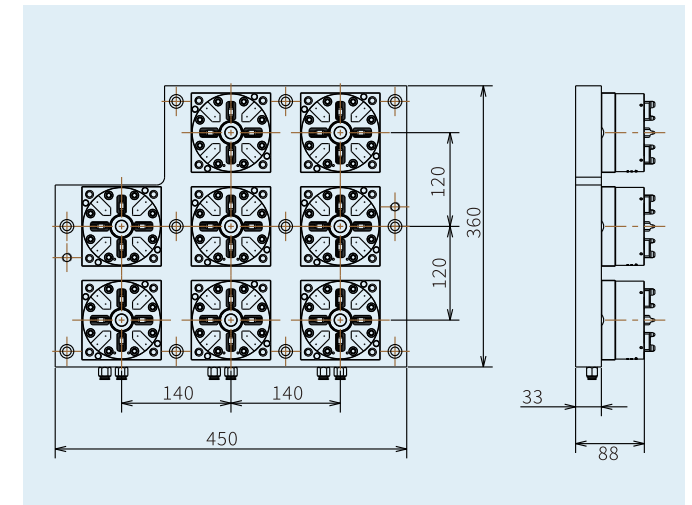

3A-100927 九中心100型气动卡盘
Nine-fold pneumatic chuck

- ▶ 规格 不锈钢, 淬硬, 气动控制0.6Mpa, 带清洁功能, 预制底板, 标准产品卡盘中心距140*120mm, 可根据客户要求订做, 价格另议
- ▶ 夹紧力 6000N
- ▶ 安装 直接安装在机床工作台上
- ▶ 应用 安装孔请参考安装说明书加工
- ▶ Version Stainless steel, hardened, pneumatic power 0.6Mpa, cleaning function, Base plate can be made in accordance Standard center to center distance 140*120mm, OEM Service available, the price is negotiable
- ▶ Clamping Power 6000N
- ▶ Mounting To be directly mounted on the table of machining center
- ▶ Application Please refer to the installation instructions for processing mounting holes

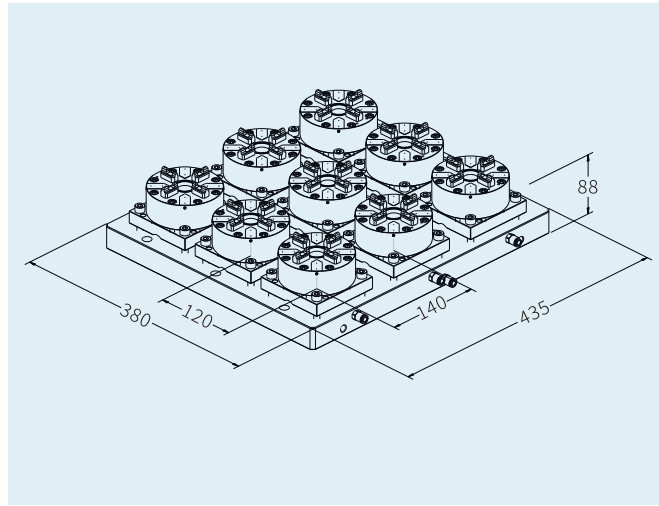

3A-100928 单列四位卡盘
Four-fold chuck

- ▶ 规格 不锈钢, 淬硬, 气动控制0.6Mpa, 带清洁功能, 预制底板, 标准产品卡盘中心距120mm, 可根据客户要求订做, 价格另议
- ▶ 夹紧力 6000N
- ▶ 安装 直接安装在机床工作台上
- ▶ 应用 安装孔请参考安装说明书加工
- ▶ Version Stainless steel, hardened, pneumatic power 0.6Mpa, cleaning function, Base plate can be made in accordance Standard center to center distance 120mm, OEM Service available, the price is negotiable
- ▶ Clamping Power 6000N
- ▶ Mounting To be directly mounted on the table of machining center
- ▶ Application Please refer to the installation instructions for processing mounting holes

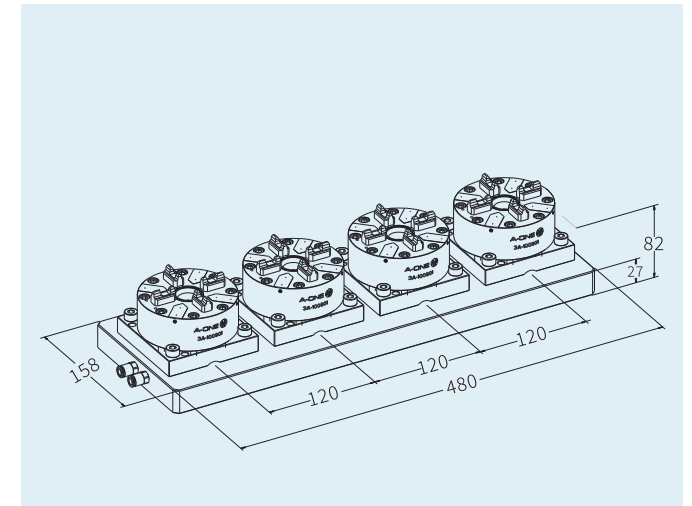

3A-100924 单列三位卡盘
Three-fold chuck

- ▶ 规格 不锈钢, 淬硬, 气动控制0.6Mpa, 带清洁功能, 预制底板, 标准产品卡盘中心距120mm, 可根据客户要求订做, 价格另议
- ▶ 夹紧力 6000N
- ▶ 安装 直接安装在机床工作台上
- ▶ 应用 安装孔请参考安装说明书加工
- ▶ Version Stainless steel, hardened, pneumatic power 0.6Mpa, cleaning function, Base plate can be made in accordance Standard center to center distance 120mm, OEM Service available, the price is negotiable
- ▶ Clamping Power 6000N
- ▶ Mounting To be directly mounted on the table of machining center
- ▶ Application Please refer to the installation instructions for processing mounting holes

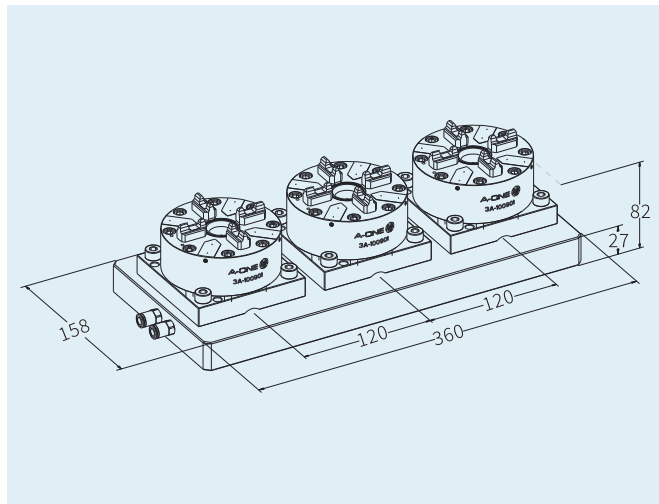

单列四位卡盘组合示意图
Three-fold chuck combination drawing

- ▶ 规格 排列组合参考图, 可按客户工作台大小组合
四中心组合 2x4、3x4、4x4
卡盘中心距 160*120mm
可根据客户要求订做, 价格另议
- ▶ Version Reference drawings
Combination can be customized according to customer's machine table
4-fold 2*4、3*4、4*4
Center to center distance 160*120mm
OEM Service available, the price is negotiable

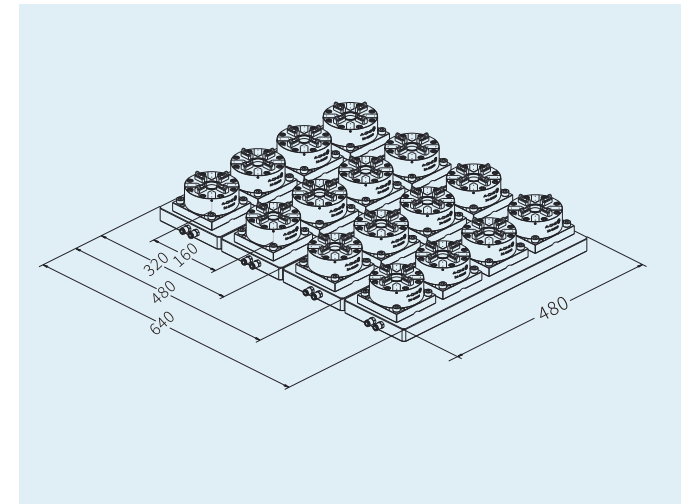

单列三位卡盘组合示意图
Three-fold chuck combination drawing

- ▶ 规格 排列组合参考图, 可按客户工作台大小组合
三中心组合 2x3、3x3、4x3
卡盘中心距 160*120mm
可根据客户要求订做, 价格另议
- ▶ Version Reference drawings
Combination can be customized according to customer's machine table
3-fold 2*3、3*3、4*3
Center to center distance 160*120mm
OEM Service available, the price is negotiable

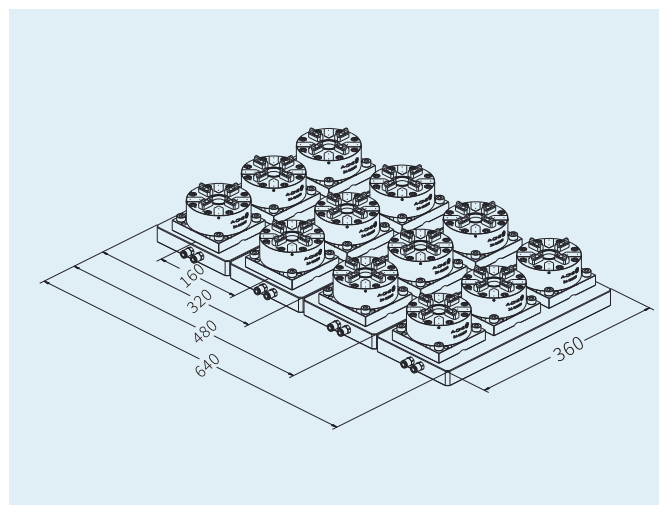

3A-100905 兼容卡盘
Multi-functional chuck

- ▶ 规格 钢, 硬质; V形刚性定位棱柱, 兼容ITS接口
- ▶ 夹紧力 6000N
- ▶ 连接 两条气路从背面
- ▶ 操作 气阀
- ▶ 应用 工作台或主轴, 也可用于客户自行设计的夹具
- ▶ Version Steel, hardened, V rigidity locating prim, compatible with ITS interface
- ▶ Clamping Power 6000N
- ▶ Connection At the rear with two lines
- ▶ Operation Air valves
- ▶ Application Used for working table or spindle, also can be used with customized tools

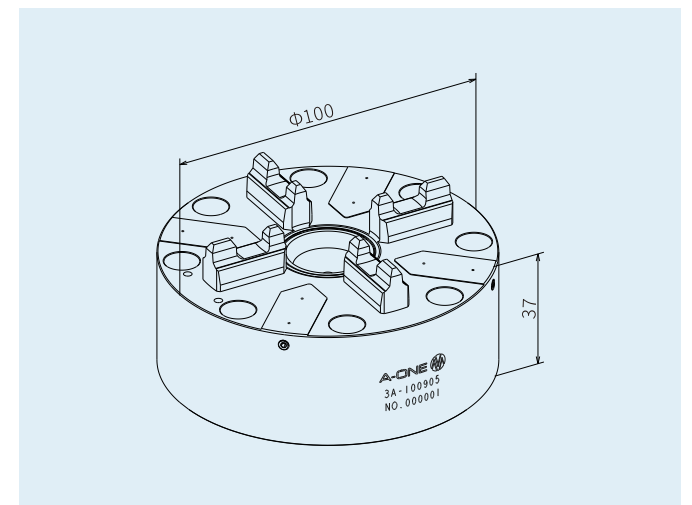

3A-100055 BT 快换卡盘
BT Quick change chuck

- ▶ 规格 特定型
- ▶ 应用 适用于特定数控机床BT台(如:Matsuura)
- ▶ 安装 4-M12从正面
- ▶ 注意 不含BT台

- ▶ Version Customized
- ▶ Application To be used on specific numerical control machine BT holder(For example : matsuura)
- ▶ Mounting 4-M12 from front side
- ▶ Note Order BT holder separately

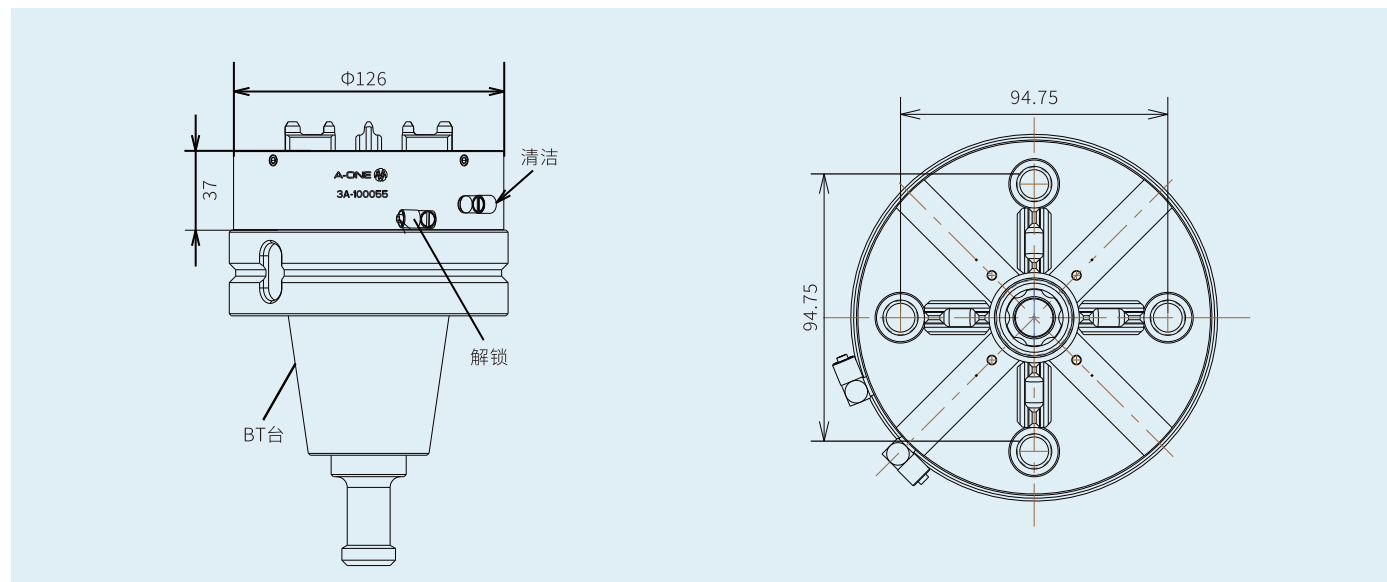

电极夹具座及电极附件

Standard electrode holder、Electrode combi

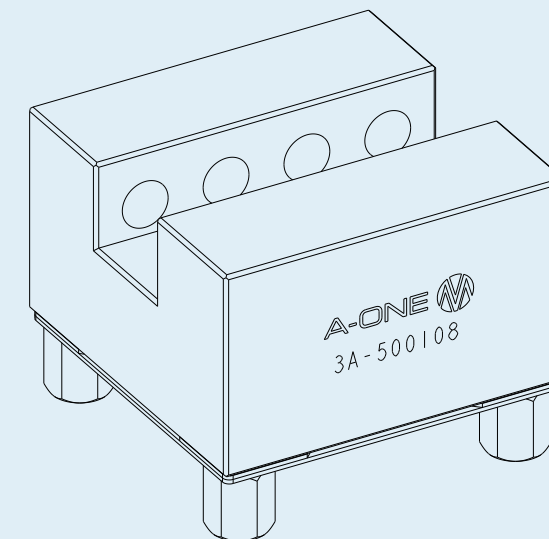

标准电极夹具座
Standard electrode holder

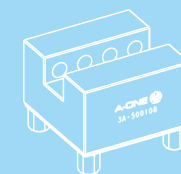

P.019~P.034

电极附件
Electrode combi

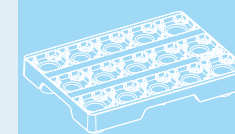

P.035~P.036

夹具座$\Phi 72$
Holder $\Phi 72$

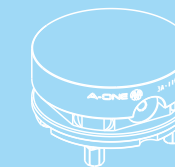

P.037~P.038

托板$\Phi 148G$
Pallet Kit $\Phi 148G$

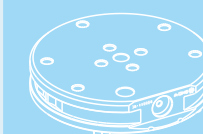

P.039~P.040

夹紧拉钉
Chucking spigots

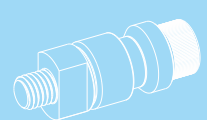

P.041~P.043

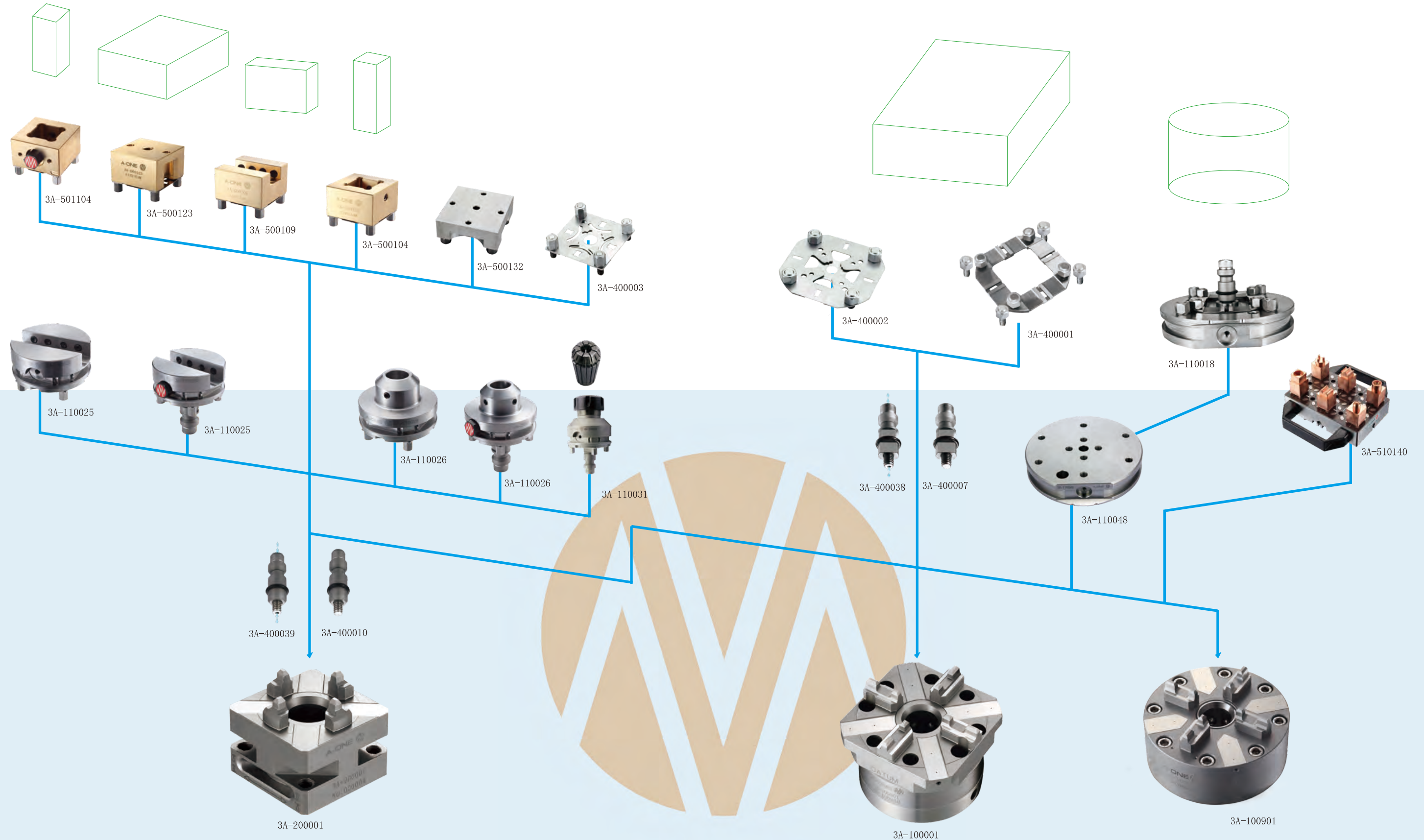

匹配。安装孔的布孔只需简单的用钻孔模板或用

定位片是夹持电极的最经济的基础件。它可直接装于电极毛坯或托板上。这样，电极的夹具也与ITS NC 编程的方法，直接在坯料上钻孔。

The centering plates are the most cost-effective base for clamping electrodes. They are mounted directly onto the blanks or pallets. This way, jigs and fixtures are also ITS compatible. The hole pattern for mounting is simply drilled into the blank with a drilling template, or by means of an NC program.

技术参数	Technical data	ITS 定位片	ITS centering plates
材料	Material	防腐蚀	corrosion-resistant
在卡盘上的系统精度	System accuracy in chuck	0.002mm	0.002mm
规格	Versions:		
定位片 50	Centering plate 50	小型电极	small electrode weights
定位片 100M8	Centering plate 100 M8	工件和电极	workpieces and electrodes
定位片 G	Centering palte 100 G	工件，切削加工中的夹具	workpieces, jigs and fixtures for chip-removal machining
操作	Handing	用 A-ONE 搬运系统或电极交换装置	with A-ONE handling systems or electrode changer.

3A-400001 强力定位片
Centering plate G Inox

- ▶ 规格 磨削，每组含8个M8的支撑脚
- ▶ 应用 工件，切削加工中的夹具
- ▶ 安装 按随附的安装说明而定
- ▶ Version Ground, including 8 supporting feet M8
- ▶ Application For workpieces, jigs and fixtures in chip-removal machining
- ▶ Mounting According to accompanying fitting instructions

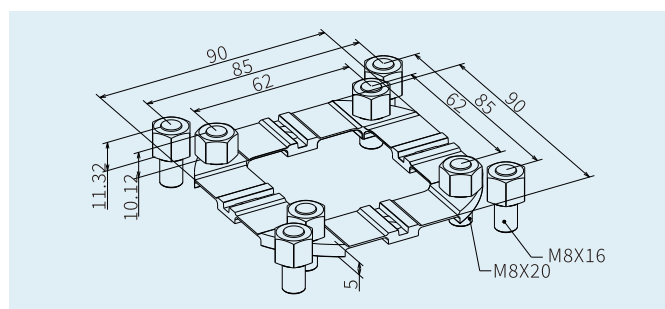

3A-400002 90型定位片
Centering plate 90 M8

- ▶ 规格 防腐蚀，每组含4个M8的支撑脚和4个M5螺钉
- ▶ 应用 工件和电极
- ▶ 安装 装于电极或工件托板上，也可直接安装于毛坯表面上
- ▶ Version Corrosion-resistant, including 4 supporting feet M8 and 4xM5 screws per plate
- ▶ Application Workpieces and electrodes
- ▶ Mounting Mounted on the electrode plate or workpiece, and on plane surface blank too

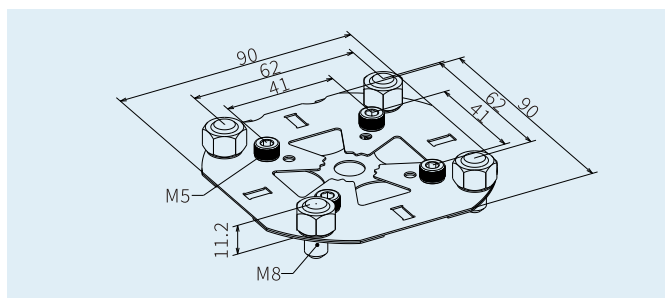

3A-400003 50型定位片
Centering plate 50

- ▶ 规格 防腐蚀，每组含4个支撑脚
- ▶ 应用 工件和电极
- ▶ 安装 装于电极或工件托板上，也可直接安装于毛坯表面上
- ▶ Version Corrosion-resistant, including 4 supporting feet per plate
- ▶ Application Workpieces and electrodes
- ▶ Mounting Mounted on the electrode plate or workpiece, and on plane surface blank too

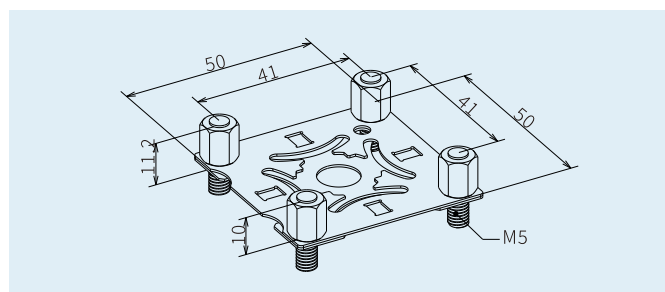

3A-400079 50*90型定位片
50*90 Centering plate

- ▶ 规格 防腐性，每组含4个支撑脚和4个M5螺钉
- ▶ 应用 特别适合长方形工件或电极生产
- ▶ 安装 安装于电极或工件托板上
- ▶ Version Corrosion-resistant, including 4 supporting feet and 4xM5 screw per plate
- ▶ Application Especially suited for producing oblong workpiece or electrode
- ▶ Mounting Mounted on the workpiece plate or electrode

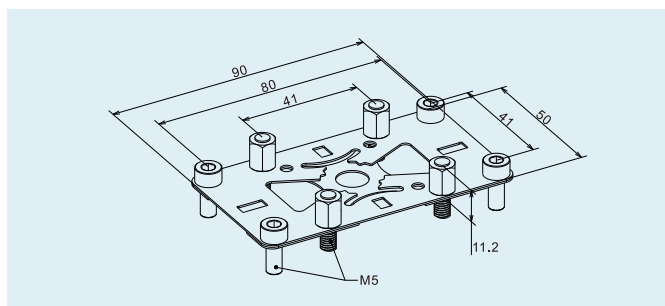

标准电极夹头用于电极的整个加工和储存过程中。经济实惠，用户可储备大量这样的夹头以供备用。标准夹具供货时不带夹紧螺钉。Standard electrode holders are used to contain electrodes for the entire machining cycle and for storage. Their economical unit price enables users to stock such holders in large quantities. The standard fixture are supplied without chucking spigots.

技术参数	Technical data	ITS标准电极夹头	ITS standard electrode holders
材料	Material	主体：铜	Body: copper
在卡盘上的系统精度	System accuracy in chuck	定位片：防腐蚀	Centering plate: corrosion-resistant
建议最大电极载重	Recommended max. weight with electrode	0.002mm	0.002mm
操作	Handling	20kg/44lbs	20kg/44lbs
		用 A-ONE 搬运系统或电极交换装置	With A-ONE Handling systems or electrode changer.

3A-500100 铜电极夹具座
Uniblank

- ▶ 规格 一套12个，主体未加工
- ▶ 应用 安装各种形状的电极和工件
- ▶ 安装 按实际需要
- ▶ Version Set of 12 units, fitted without machining of body
- ▶ Application To mount electrodes and workpieces of various shapes
- ▶ Mounting As required

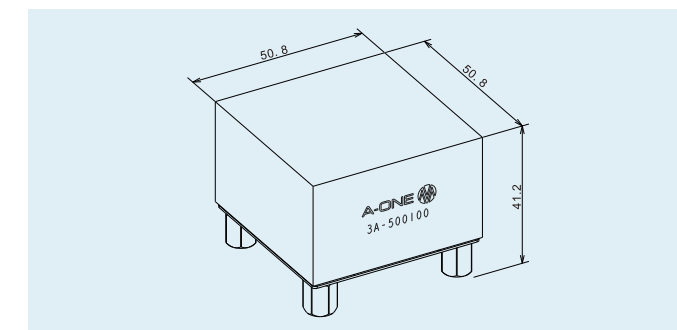

3A-501100 铜电极夹具座
Uniblank

- ▶ 规格 一套12个，预留安装数据承载器位置。单独订购芯片 3A-400054
- ▶ Version Set of 12 units, prepared for the installation of the code carrier. Order chip 3A-400054 separately

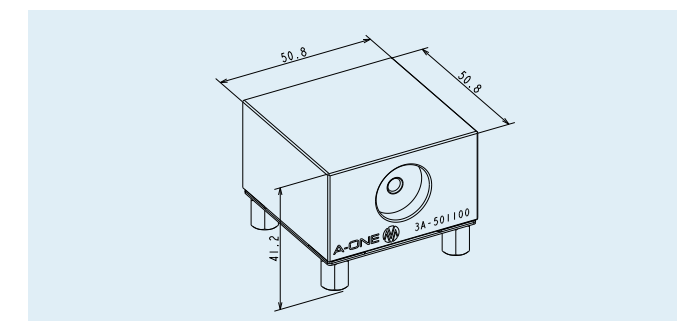

3A-500103 铜电极夹具座
Prisround

- ▶ 规格 一套12个，每个包含2个固定螺钉
- ▶ 应用 用于夹持最大20mm正方形电极或工件
- ▶ Version Set of 12 units, Each contains 2 fixed screws
- ▶ Application For holding the largest 20mm square electrode or workpiece

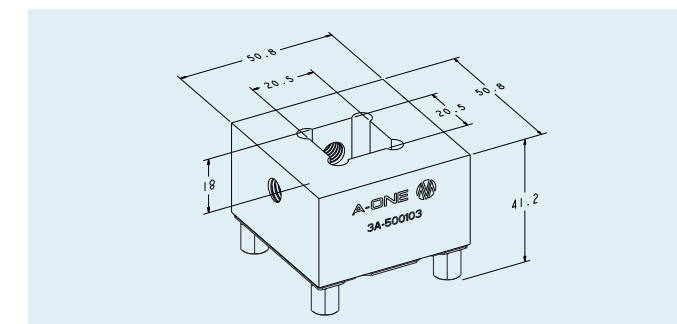

3A-501103 铜电极夹具座
Prisround

- ▶ 规格 一套12个，预留安装数据承载器位置。单独订购芯片 3A-400054
- ▶ Version Set of 12 units, prepared for the installation of the code carrier. Order chip 3A-400054 separately

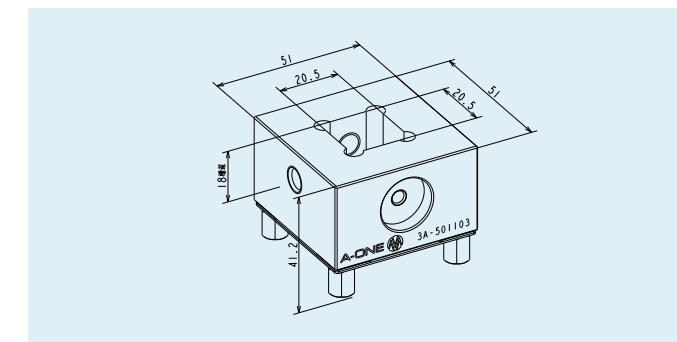

标准电极夹具座(铜)
Standard electrode holder(brass)

3A-500104 铜电极夹具座
Prisround

- ▶ 规格 一套12个, 每个包含2个固定螺钉
- ▶ 应用 用于夹持最大25mm正方形电极或工件
- ▶ Version Set of 12 units, Each contains 2 fixed screws
- ▶ Application For holding the largest 25mm square electrode or workpiece

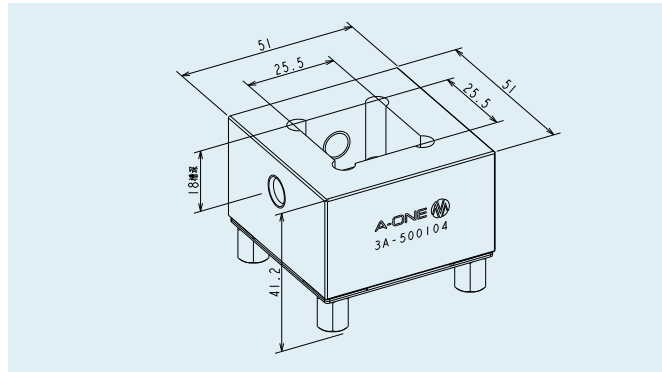

3A-500108 铜电极夹具座
Uniholder

- ▶ 规格 一套12个, 每个包含4个固定螺钉
- ▶ 应用 用于夹持最大15mm长方形电极或工件
- ▶ Version Set of 12 units, Each contains 4 fixed screws
- ▶ Application For holding the largest 15mm oblong electrode and workpiece

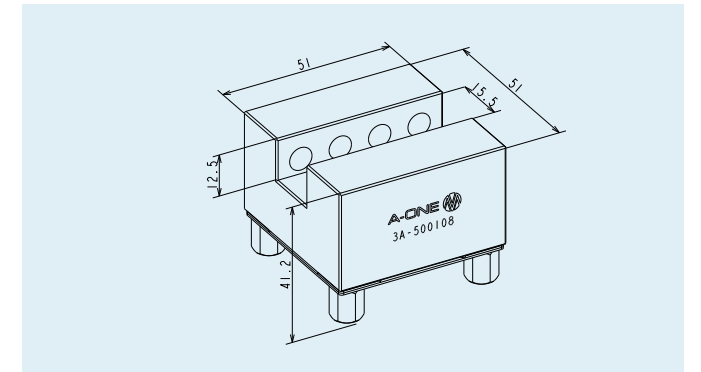

3A-501104 铜电极夹具座
Prisround

- ▶ 规格 一套12个, 预留安装数据承载器位置。单独订购芯片 3A-400054
- ▶ Version Set of 12 units, prepared for the installation of the code carrier. Order chip 3A-400054 separately

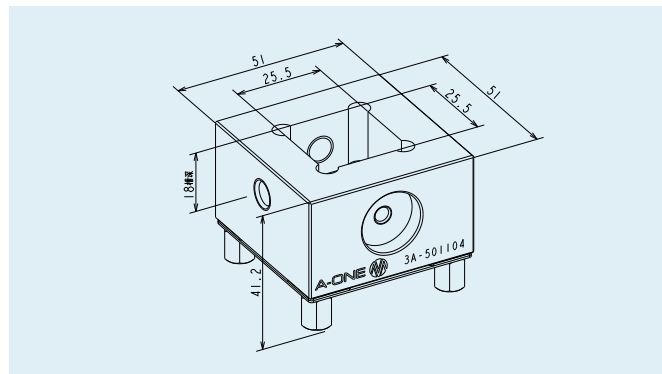

3A-501108 铜电极夹具座
Uniholder

- ▶ 规格 一套12个, 预留安装数据承载器位置。单独订购芯片 3A-400054
- ▶ Version Set of 12 units, prepared for the installation of the code carrier. Order chip 3A-400054 separately

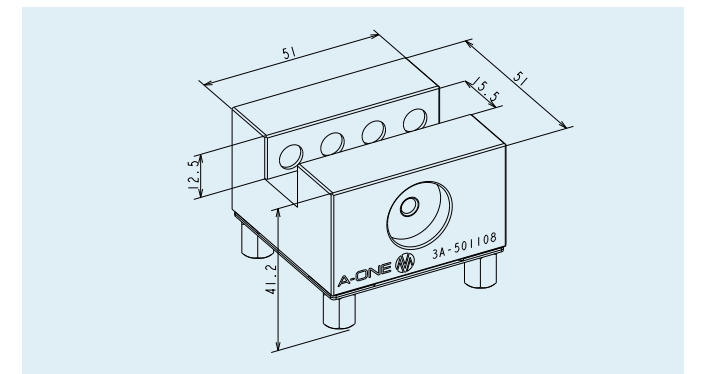

3A-500105 铜电极夹具座
Prisround

- ▶ 规格 一套12个, 每个包含2个固定螺钉
- ▶ 应用 用于夹持最大30mm正方形电极或工件
- ▶ Version Set of 12 units, Each contains 2 fixed screws
- ▶ Application For holding the largest 30mm square electrode or workpiece

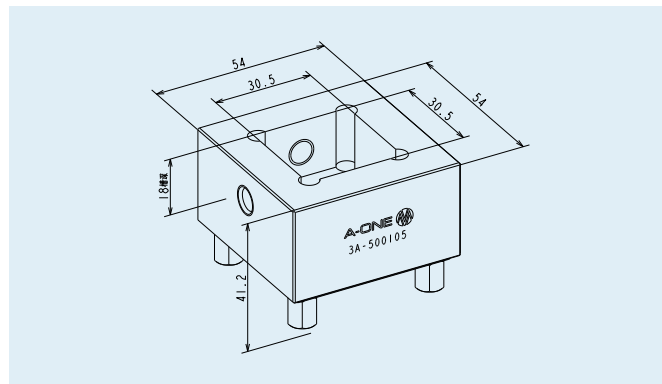

3A-500109 铜电极夹具座
Uniholder

- ▶ 规格 一套12个, 每个包含4个固定螺钉
- ▶ 应用 用于夹持最大20mm长方形电极或工件
- ▶ Version Set of 12 units, Each contains 4 fixed screws
- ▶ Application For holding the largest 20mm oblong electrode and workpiece

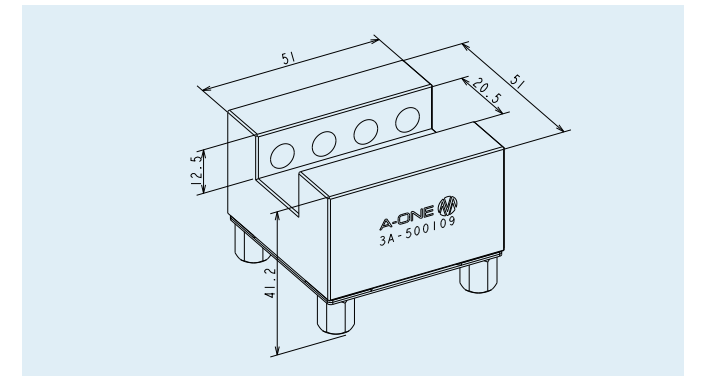

3A-501105 铜电极夹具座
Prisround

- ▶ 规格 预留安装数据承载器位置。单独订购芯片 3A-400054
- ▶ Version Prepared for the installation of the code carrier. Order chip 3A-400054 separately

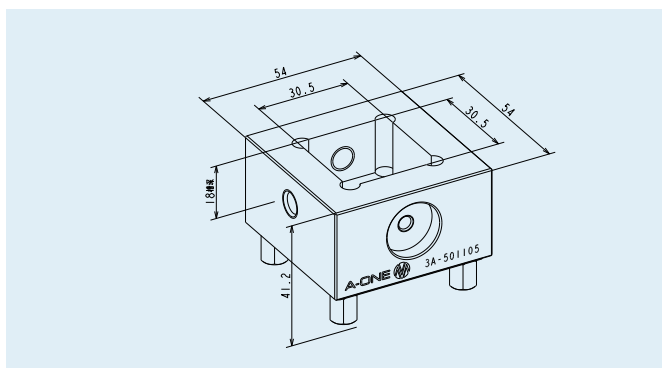

3A-501109 铜电极夹具座
Uniholder

- ▶ 规格 一套12个, 预留安装数据承载器位置。单独订购芯片 3A-400054
- ▶ Version Set of 12 units, prepared for the installation of the code carrier. Order chip 3A-400054 separately

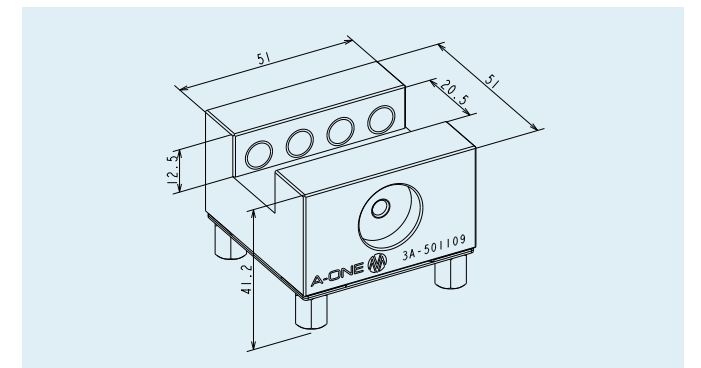

3A-500110 铜电极夹具座
Uniholder

- ▶ 规格 一套12个, 每套包含4个固定螺钉
- ▶ 应用 用于夹持最大25mm长方形电极或工件
- ▶ Version Set of 12 units, Each set contains 4 fixed screws
- ▶ Application For holding the largest 25mm oblong electrode and workpiece

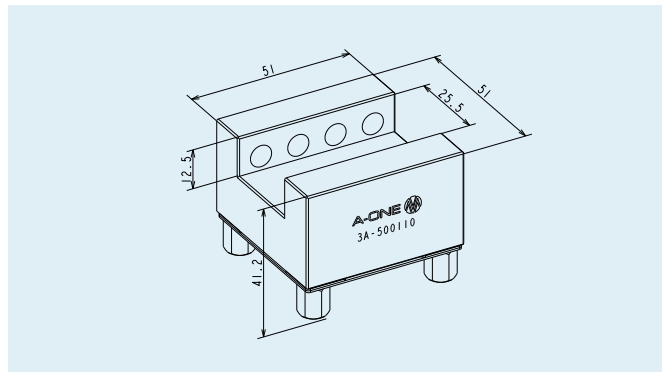

3A-500116 铜电极夹具座
Uniholder

- ▶ 规格 一套12个, 每个包含4个固定螺钉
- ▶ 应用 用于夹持最大35mm长方形电极或工件
- ▶ Version Set of 12 units, Each contains 4 fixed screws
- ▶ Application For holding the largest 35mm oblong electrode and workpiece

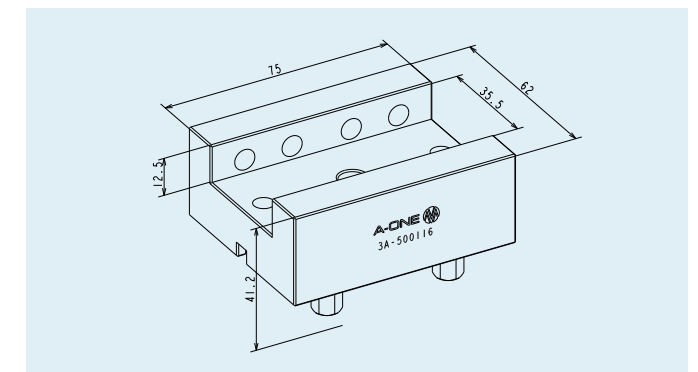

3A-501110 铜电极夹具座
Uniholder

- ▶ 规格 预留安装数据承载器位置。单独订购芯片3A-400054
- ▶ Version Prepared for the installation of the code carrier. Order chip 3A-400054 separately

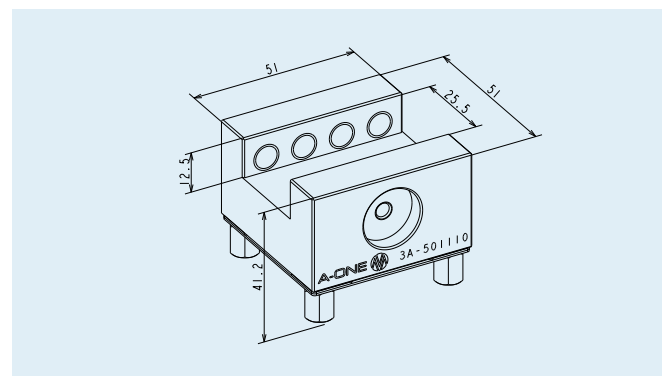

3A-501116 铜电极夹具座
Uniholder

- ▶ 规格 预留安装数据承载器位置。单独订购芯片3A-400054
- ▶ Version Prepared for the installation of the code carrier. Order chip 3A-400054 separately

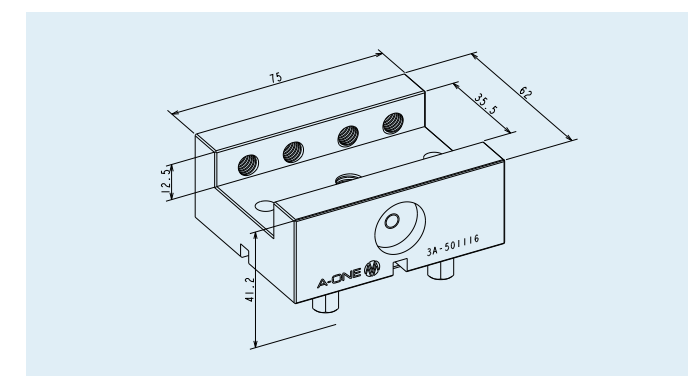

3A-500115 铜电极夹具座
Uniholder

- ▶ 规格 一套12个, 每个包含4个固定螺钉
- ▶ 应用 用于夹持最大30mm长方形电极或工件
- ▶ Version Set of 12 units, Each contains 4 fixed screws
- ▶ Application For holding the largest 30mm oblong electrode or workpiece

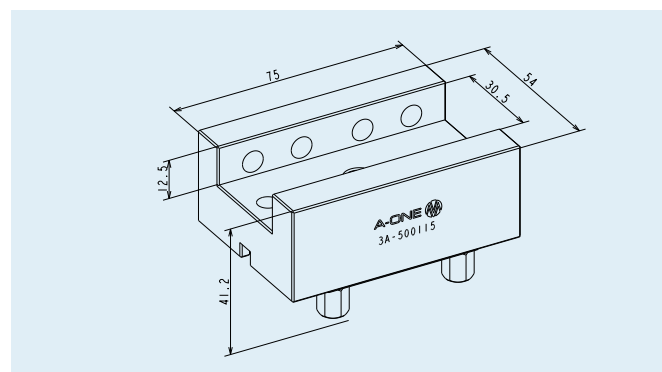

3A-500123 铜电极夹具座
Uniplate

- ▶ 规格 50.8 x 50.8mm表面平
- ▶ 应用 安装基准表面大于50mm的电极或工件
- ▶ Version 50.8x50.8mm surface
- ▶ Application To mount electrodes and workpieces with shaft sizes of up to 50mm

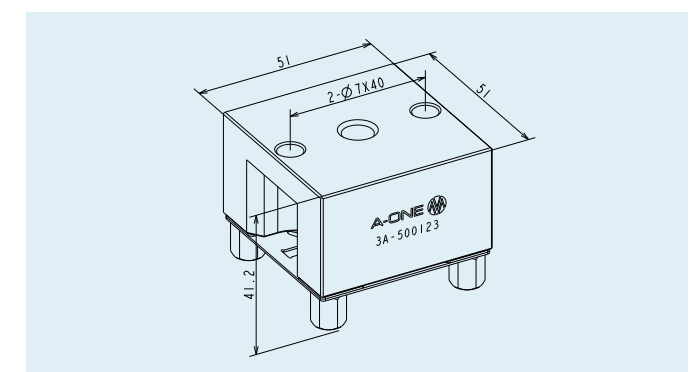

3A-501115 铜电极夹具座
Uniholder

- ▶ 规格 预留安装数据承载器位置。单独订购芯片3A-400054
- ▶ Version Prepared for the installation of the code carrier. Order chip 3A-400054 separately

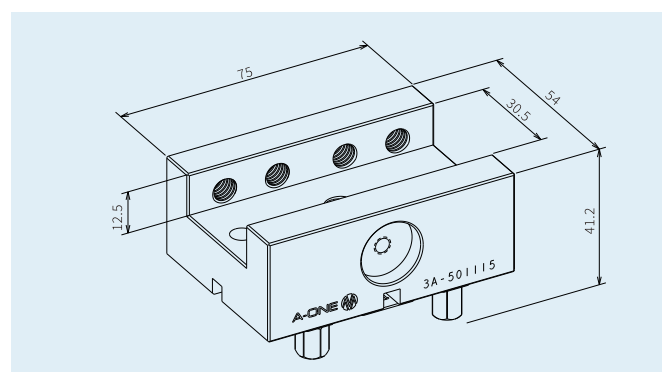

3A-501123 铜电极夹具座
Uniplate

- ▶ 规格 预留安装数据承载器位置。单独订购芯片3A-400054
- ▶ Version Prepared for the installation of the code carrier. Order chip 3A-400054 separately

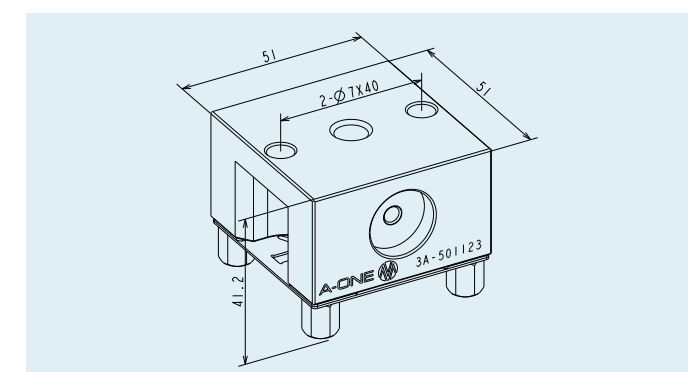

标准电极夹具座(铝)
Standard electrode holder(aluminum)

3A-500124 铜电极夹具座
Uniplate

- ▶ 规格 50.8x75mm表面平
- ▶ 应用 安装基准表面大于75mm的电极或工件
- ▶ Version 50.8x75mm surface
- ▶ Application To mount electrodes and workpieces with shaft sizes of up to 75mm

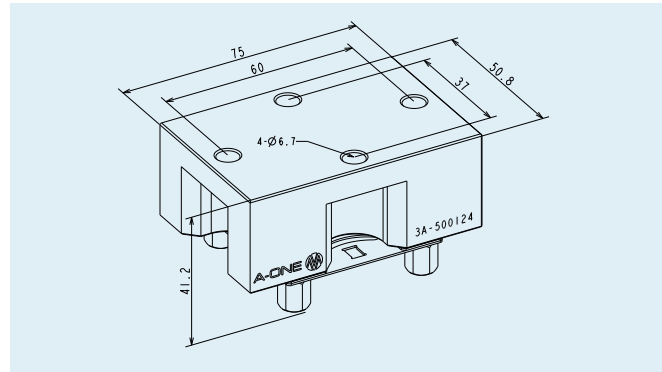

3A-500132 铝质万用块80×80mm
Uniplate alu 80×80mm

- ▶ 规格 一套4个, 铝质, 系统尺寸100mm, 带M8支撑脚
- ▶ 应用 安装基准表面大于70mm的电极和工件
- ▶ 安装 用4个M6螺钉与基准面相连
- ▶ Version Set of 4units, aluminum, system size 100mm, with M8 supports feet
- ▶ Application To mount electrodes and workpieces with a base surface of more than 70mm
- ▶ Mounting With 4 x M6 bolts into the base surface

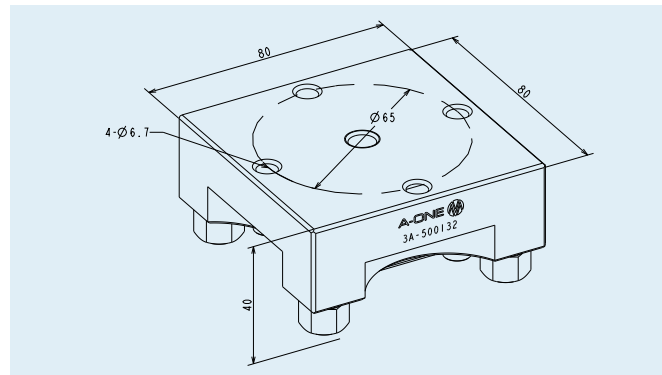

3A-500127 铝电极夹具座
Aluminum electrode holder

- ▶ 规格 65x100mm表面平
- ▶ 应用 安装基准表面大于100mm的电极或工件
- ▶ Version 65x100mm surface
- ▶ Application To mount datum surface is greater than 100mm electrode or workpiece

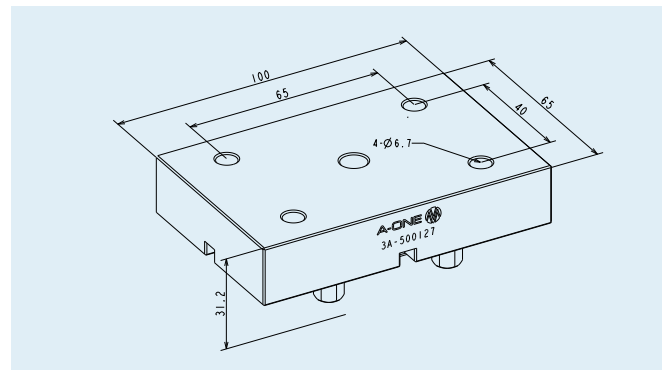

3A-500128 铝电极夹具座
Aluminum electrode holder

- ▶ 规格 100x100mm表面平, 90型定位片
- ▶ 应用 安装基准表面大于100mm的电极或工件
- ▶ Version 100x100mm surface, type 90 locating surface
- ▶ Application The mounting datum plane is greater than 100mm electrode or ten workpiece

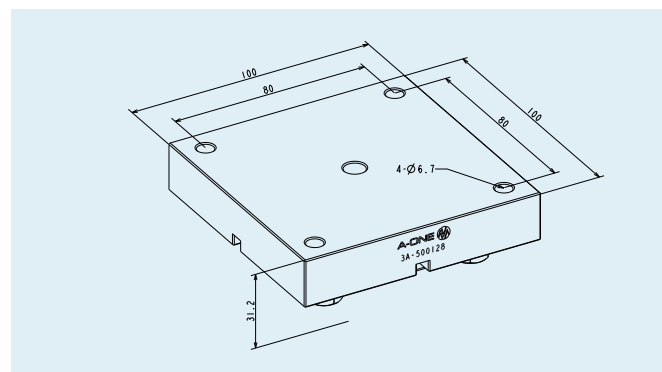

标准电极夹具座(钢)
Standard electrode holder(steel)

3A-520103 钢电极夹具座
Steel holder

- ▶ 材质 S136H
- ▶ 硬度 HRC30-36
- ▶ 规格 一套12个, 每个包含2个固定螺钉
- ▶ 应用 用于夹持最大20mm正方形电极或工件
- ▶ Material S136H
- ▶ Hardness HRC30-36
- ▶ Version Set of 12 units, Each contains 2 fixed screws
- ▶ Application For holding the largest 20mm square electrode or workpiece

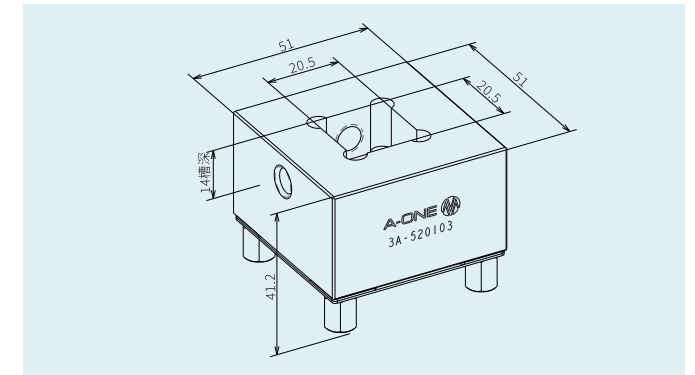

3A-521103 钢电极夹具座
Steel holder

- ▶ 规格 一套12个, 预留安装数据承载器位置。单独订购芯片 3A-400054
- ▶ Version Set of 12 units, prepared for the installation of the code carrier. order chip 3A-400054 separately

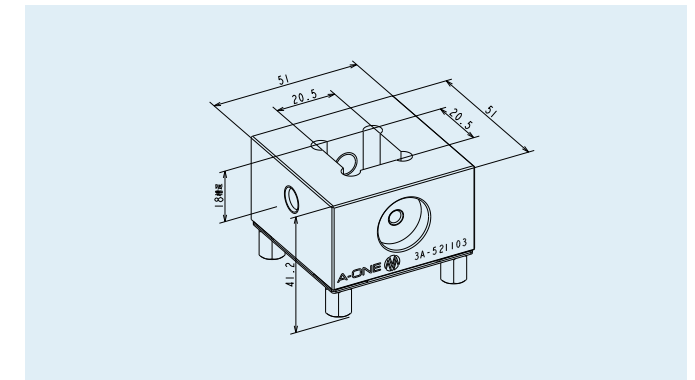

3A-520104 钢电极夹具座
Steel holder

- ▶ 材质 S136H
- ▶ 硬度 HRC30-36
- ▶ 规格 一套12个, 每个包含2个固定螺钉
- ▶ 应用 用于夹持最大25mm正方形电极或工件
- ▶ Material S136H
- ▶ Hardness HRC30-36
- ▶ Version Set of 12 units, Each contains 2 fixed screws
- ▶ Application For holding the largest 25mm square electrode or workpiece

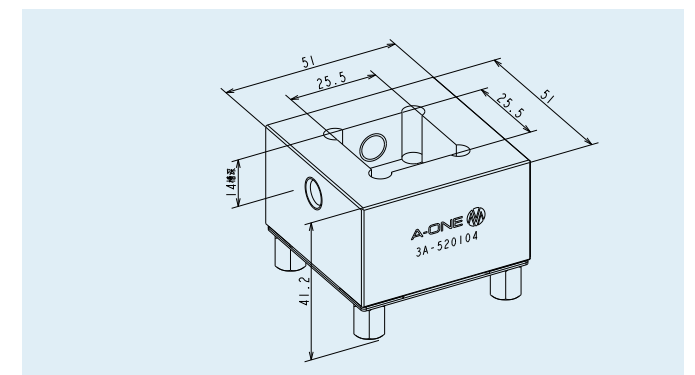

3A-521104 钢电极夹具座
Steel holder

- ▶ 规格 一套12个, 预留安装数据承载器位置。单独订购芯片 3A-400054
- ▶ Version Set of 12 units, prepared for the installation of the code carrier. Order chip 3A-400054 separately

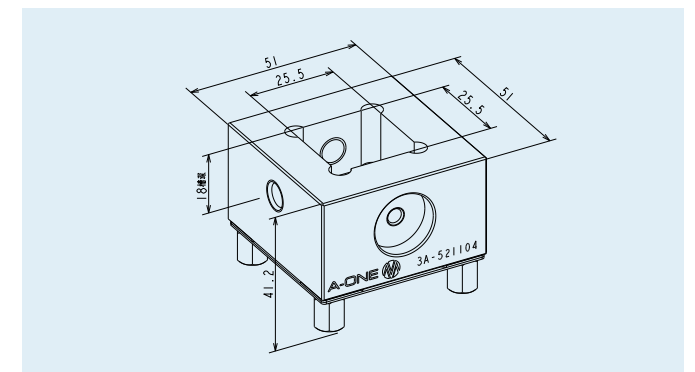

3A-520105 钢电极夹具座
Steel holder

- ▶ 材质 S136H
- ▶ 硬度 HRC30-36
- ▶ 规格 一套12个, 每个包含4个固定螺钉
- ▶ 应用 用于夹持最大30mm正方形电极或工件
- ▶ Material S136H
- ▶ Hardness HRC30-36
- ▶ Version Set of 12 units, Each contains 2 fixed screws
- ▶ Application For holding the largest 30mm square electrode or workpiece

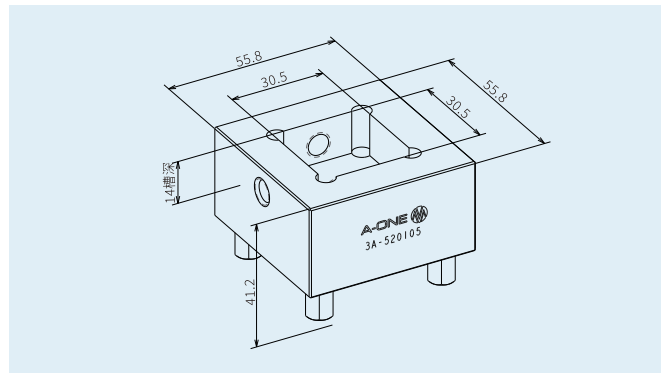

3A-520109 钢电极夹具座
Steel holder

- ▶ 材质 S136H
- ▶ 硬度 HRC30-36
- ▶ 规格 一套12个, 每个包含4个固定螺钉
- ▶ 应用 用于夹持最大20mm长方形电极或工件
- ▶ Material S136H
- ▶ Hardness HRC30-36
- ▶ Version Set of 12 units, Each contains 4 fixed screwss
- ▶ Application For holding the largest 20mm rectangle electrode and workpiece

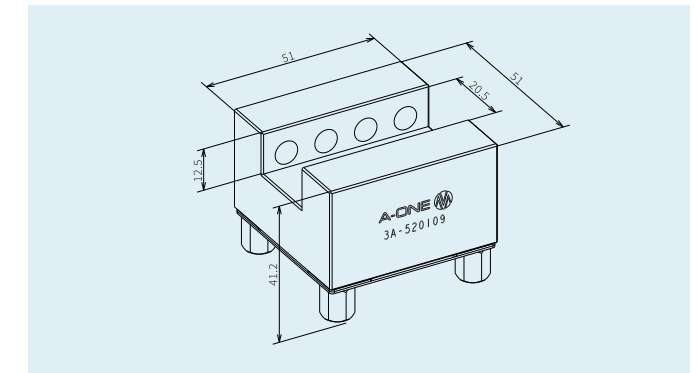

3A-521105 钢电极夹具座
Steel holder

- ▶ 规格 预留安装数据承载器位置。单独订购芯片3A-400054
- ▶ Version Prepared for the installation of the code carrier
Order chip 3A-400054 separately

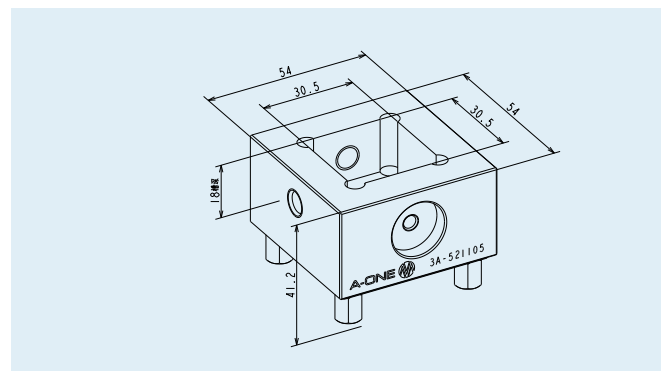

3A-521109 钢电极夹具座
Steel holder

- ▶ 规格 一套12个, 预留安装数据承载器位置。单独订购芯片3A-400054
- ▶ Version Set of 12 units, prepared for the installation of the code carrier.
Order chip 3A-400054 separately

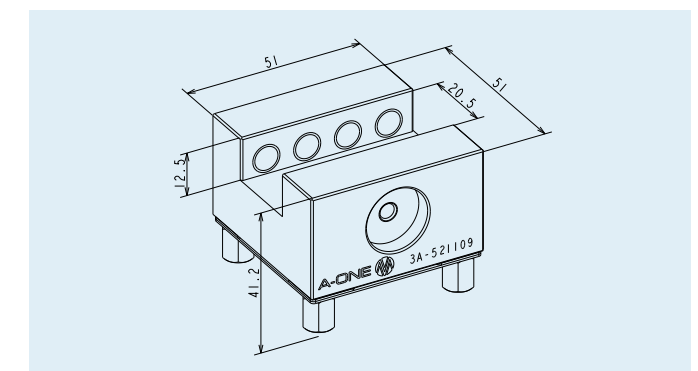

3A-520108 钢电极夹具座
Steel holder

- ▶ 材质 S136H
- ▶ 硬度 HRC30-36
- ▶ 规格 一套12个, 每个包含4个固定螺钉
- ▶ 应用 用于夹持最大15mm长方形电极或工件
- ▶ Material S136H
- ▶ Hardness HRC30-36
- ▶ Version Set of 12 units, Each contains 4 fixed screws
- ▶ Application For holding the largest 15mm rectangle electrode and workpiece

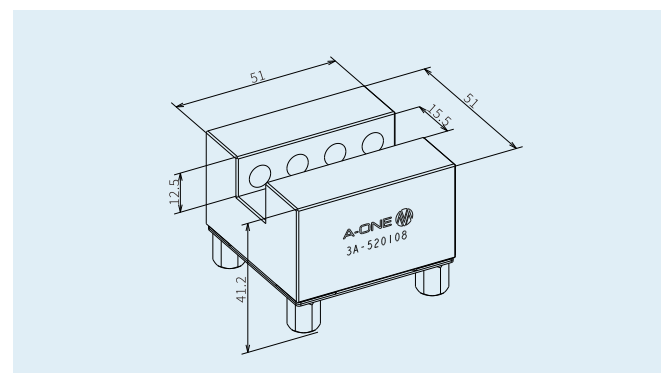

3A-520110 钢电极夹具座
Steel holder

- ▶ 材质 S136H
- ▶ 硬度 HRC30-36
- ▶ 规格 一套12个, 每套包含4个固定螺钉
- ▶ 应用 用于夹持最大25mm长方形电极或工件
- ▶ Material S136H
- ▶ Hardness HRC30-36
- ▶ Version Set of 12 units, Each set contains 4 fixed screws
- ▶ Application For holding the largest 25mm rectangle electrode and workpiece

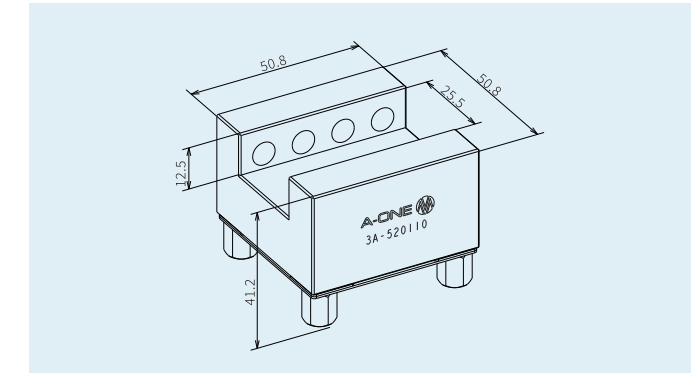

3A-521108 钢电极夹具座
Steel holder

- ▶ 规格 一套12个, 预留安装数据承载器位置。单独订购芯片3A-400054
- ▶ Version Set of 12 units, prepared for the installation of the code carrier.
Order chip 3A-400054 separately

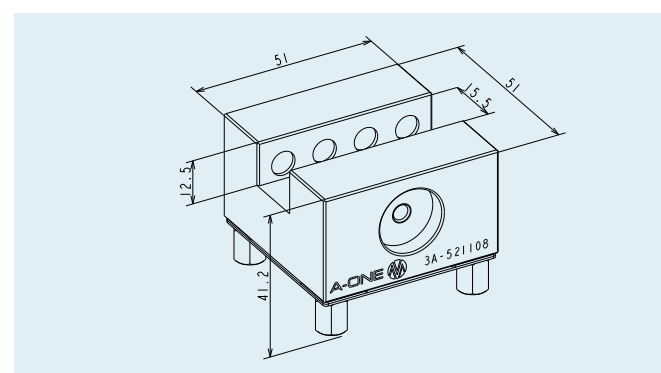

3A-521110 钢电极夹具座
Steel holder

- ▶ 规格 预留安装数据承载器位置。单独订购芯片3A-400054
- ▶ Version Prepared for the installation of the code carrier.
Order chip 3A-400054 separately

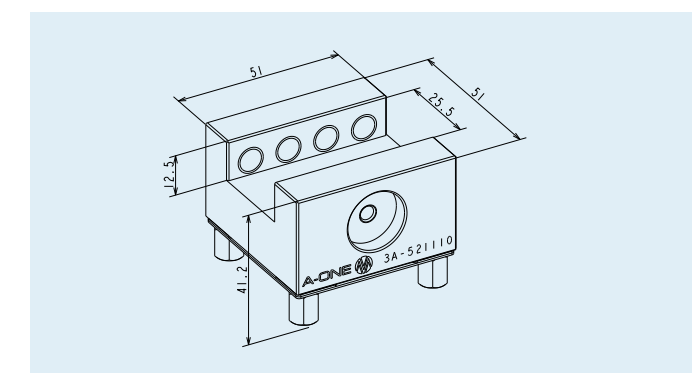

3A-520115 钢电极夹具座
Steel holder

- ▶ 材质 S136H
- ▶ 硬度 HRC30-36
- ▶ 规格 一套12个, 每个包含4个固定螺钉
- ▶ 应用 用于夹持最大30mm 长方形电极或工件
- ▶ Material S136H
- ▶ Hardness HRC30-36
- ▶ Version Set of 12 units, Each contains 4 fixed screws
- ▶ Application For holding the largest 30mm rectangle electrode or workpiece

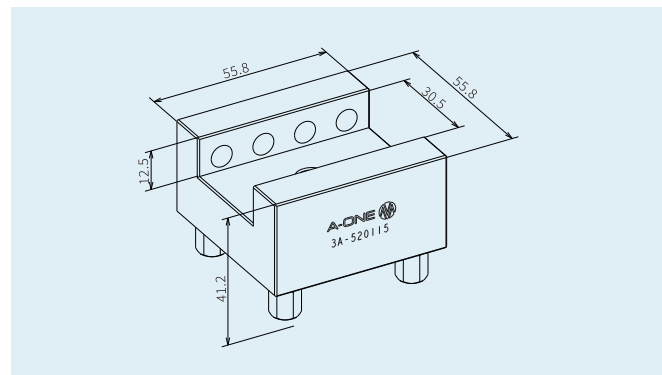

3A-520117 钢电极夹具座
Steel holder

- ▶ 材质 S136H
- ▶ 硬度 HRC30-36
- ▶ 规格 一套12个, 每个包含4个固定螺钉
- ▶ 应用 用于夹持最大40mm正方形电极或工件
- ▶ Material S136H
- ▶ Hardness HRC30-36
- ▶ Version Set of 12 units, Each contains 4 fixed screws
- ▶ Application For holding the largest 40mm square electrode or workpiece

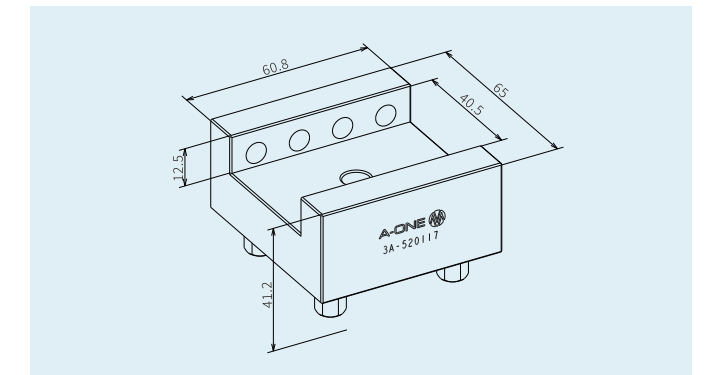

3A-521115 钢电极夹具座
Steel holder

- ▶ 规格 预留安装数据承载器位置。单独订购芯片3A-400054
- ▶ Version Prepared for the installation of the code carrier
Order chip 3A-400054 separately

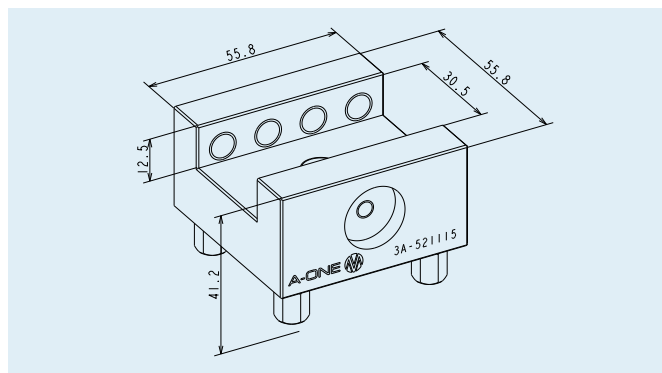

3A-521117 钢电极夹具座
Steel holder

- ▶ 规格 预留安装数据承载器位置。单独订购芯片 3A-400054
- ▶ Version Prepared for the installation of the code carrier
Order chip 3A-400054 separately

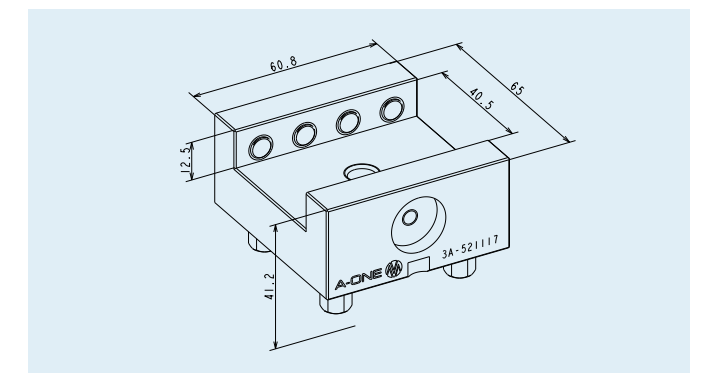

3A-520116 钢电极夹具座
Steel holder

- ▶ 材质 S136H
- ▶ 硬度 HRC30-36
- ▶ 规格 一套12个, 每个包含4个固定螺钉
- ▶ 应用 用于夹持最大35mm长方形电极或工件
- ▶ Material S136H
- ▶ Hardness HRC30-36
- ▶ Version Set of 12 units, Each contains 4 fixed screws
- ▶ Application For holding the largest 35mm rectangle electrode and workpiece

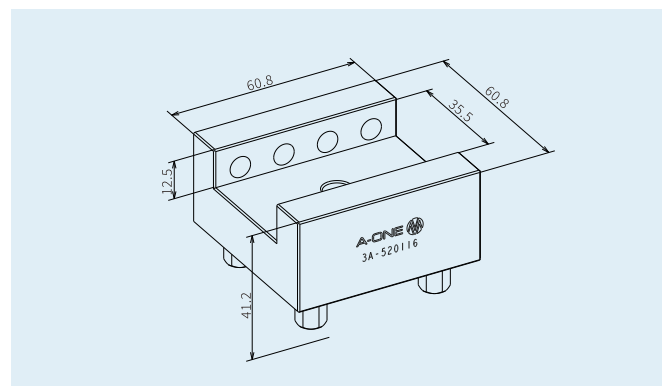

3A-520118 钢电极夹具座 U 45
Steel holder U45

- ▶ 材质 S136H
- ▶ 硬度 HRC30-36
- ▶ 规格 一套12个, 每个包含4个固定螺钉
- ▶ 应用 用于夹持最大45mm长方形电极或工件
- ▶ Material S136H
- ▶ Hardness HRC30-36
- ▶ Version Set of 12 units, Each contains 4 fixed screws
- ▶ Application For holding the largest 45mm rectangle electrode and workpiece

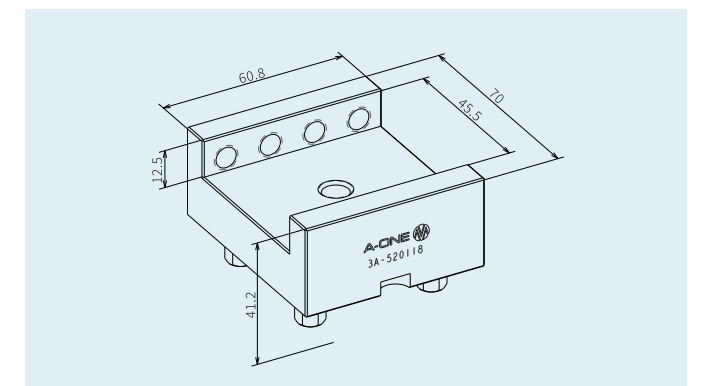

3A-521116 钢电极夹具座
Steel holder

- ▶ 规格 预留安装数据承载器位置。单独订购芯片3A-400054
- ▶ Version Prepared for the installation of the code carrier
Order chip 3A-400054 separately

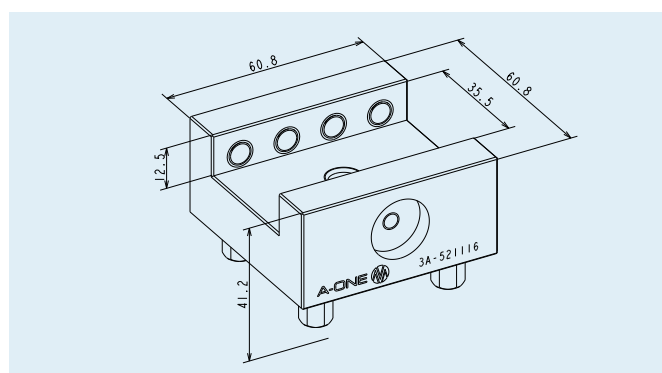

3A-521118 钢电极夹具座
Steel holder

- ▶ 规格 预留安装数据承载器位置。单独订购芯片 3A-400054
- ▶ Version Prepared for the installation of the code carrier
Order chip 3A-400054 separately

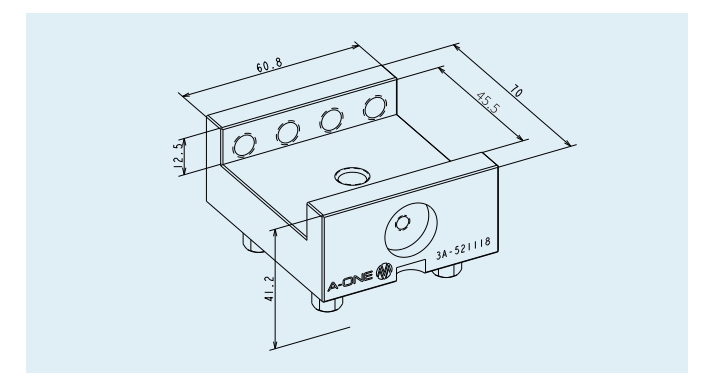

3A-520119 钢电极夹具座U50
Steel holder U50

- ▶ 材质 S136H
- ▶ 硬度 HRC30-36
- ▶ 规格 一套12个, 每个包含4个固定螺钉
- ▶ 应用 用于夹持最大50mm长方形电极或工件
- ▶ Material S136H
- ▶ Hardness HRC30-36
- ▶ Version Set of 12 units, Each contains 4 fixed screws
- ▶ Application For holding the largest 50mm rectangle electrode and workpiece

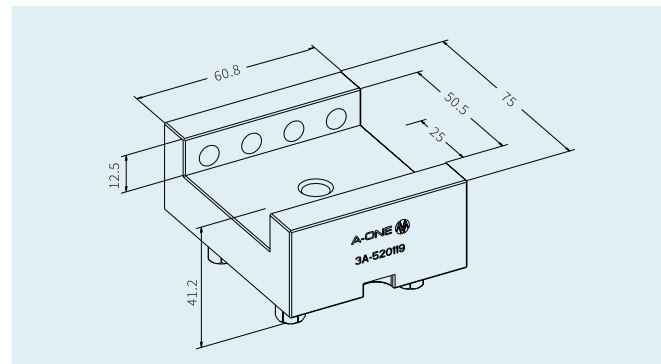

3A-520132 钢平板座(槽)
Steel flat holder

- ▶ 规格 160X91mm承载面; 六个M8(从底面)
- ▶ 应用 安装基准表面大于120的工件或电极
- ▶ Version 160X 91mm bearing surface, 6xM8 screws (from the bottom)
- ▶ Application Mounting workpieces or electrodes with a reference surface larger than 120mm

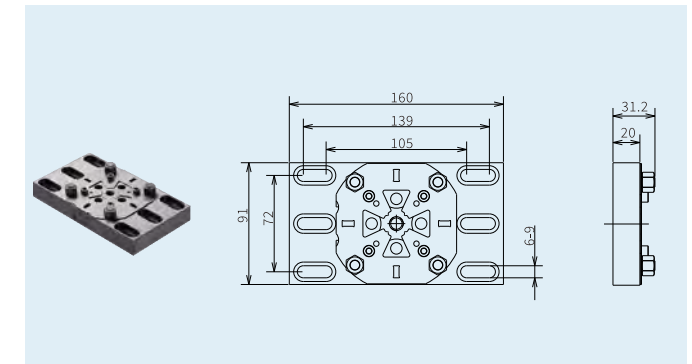

3A-521119 钢电极夹具座
Steel holder

- ▶ 规格 预留安装数据承载器位置。单独订购芯片 3A-400054
- ▶ Version Prepared for the installation of the code carrier
Order chip 3A-400054 separately

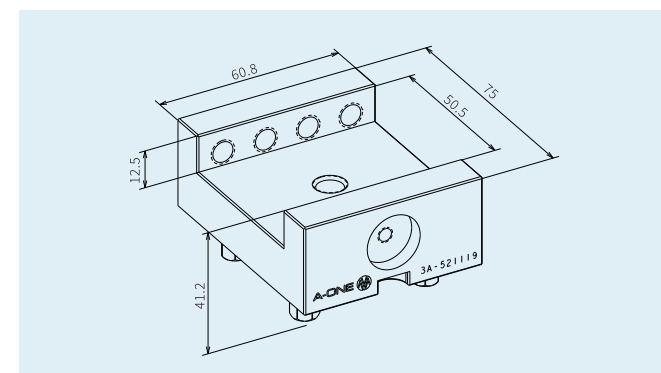

3A-520131 钢平板座(孔)
Steel flat holder

- ▶ 规格 160X91mm承载面; 六个M8(从底面)
- ▶ 应用 安装基准表面大于150的工件或电极
- ▶ Version 160X 91mm bearing surface, 6x M8 screws (from the bottom)
- ▶ Application Mounting workpieces or electrodes with a reference surface larger than 150mm

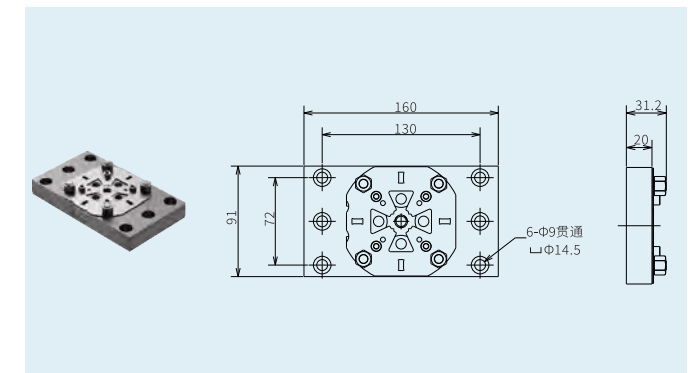

3A-520124 钢电极夹具座
Steel holder

- ▶ 材质 S136H
- ▶ 硬度 HRC30-36
- ▶ 规格 50.8x80mm表面平
- ▶ 应用 安装基准表面大于75mm的电极或工件
- ▶ Material S136H
- ▶ Hardness HRC30-36
- ▶ Version 50.8x75mm surface
- ▶ Application To mount electrodes and workpieces with shaft sizes of up to 75mm

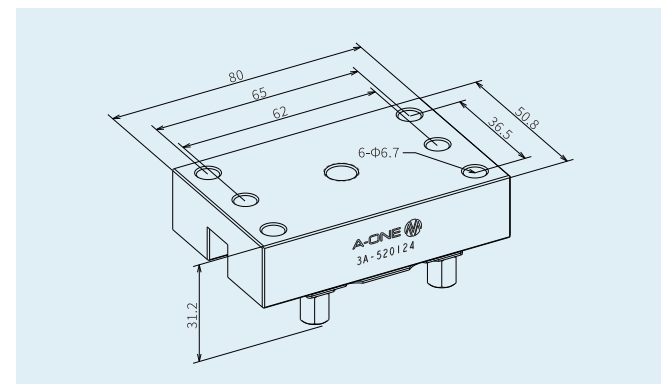

3A-521124 钢电极夹具座
Steel holder

- ▶ 规格 预留安装数据承载器位置。单独订购芯片 3A-400054
- ▶ Version Prepared for the installation of the code carrier
Order chip 3A-400054 separately

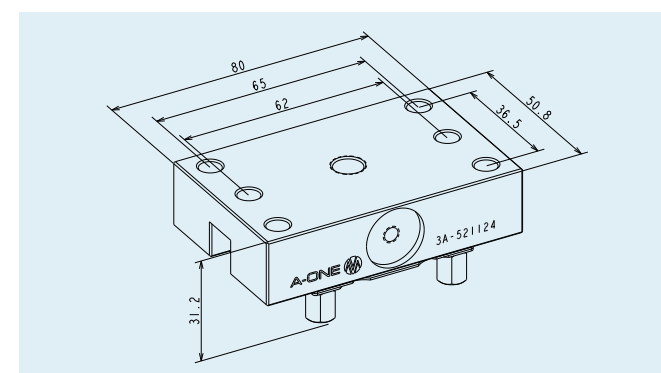

3A-400013 扭力扳手
Torque wrench

- ▶ 规格 扭力可调4-12nm
- ▶ 应用 安装调试3A-400003定位片（50型）脚钉用
- ▶ Version Torque is adjustable 4-12nm
- ▶ Application Can be used when assemble screws in 3A-400003 (50 type) centering plate



3A-400054 带芯片的固定装置H14
Chip with holder

- ▶ 规格 衬套中装有嵌入式数据承载器。电器导线互联系统芯片：只读
- ▶ 应用 应用于任何预先准备放置芯片的A-ONE电极夹头和托板
- ▶ 注意 扫描器另购
- ▶ Version Sleeve fitting with built-in datacarrier. Rapid chip: read only.
- ▶ Application In any A-ONE electrode holder and pallet which has been prepared for it
- ▶ Note Scan machine order separately

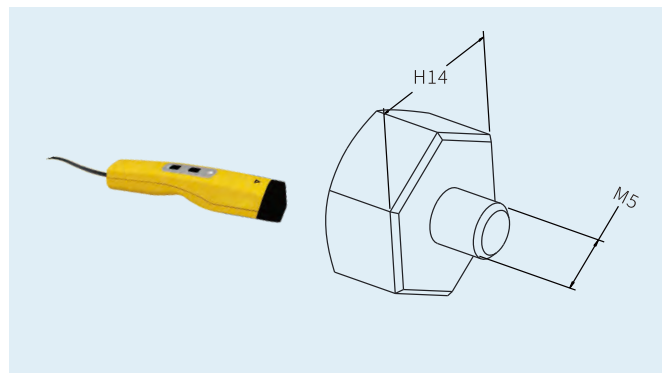

3A-400022 12格泡沫盒
System stand 50 12-fold

- ▶ 规格 一套10个，苯乙烯泡沫盒
- ▶ 应用 储存和运输系统尺寸50的电极夹头
- ▶ Version Set of 10, styrene stands
- ▶ Note Storage and transport of electrode holders system size 50

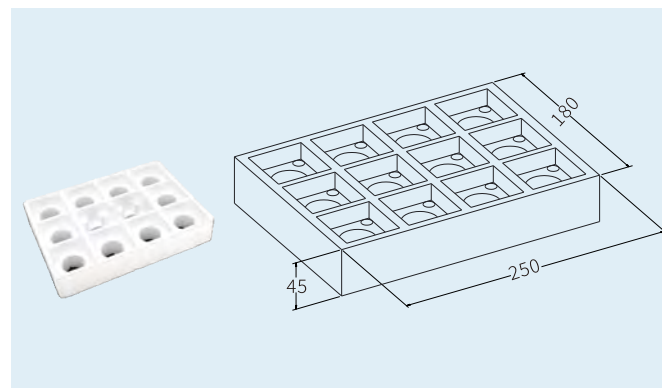

3A-300025 高胶盒
System stand

- ▶ 规格 塑料，一套10个
- ▶ 应用 用于存放4个50的电极夹头或1个ø115/148mm的托板
- ▶ 注意 系统座可无间隙地连在一起，例如，可存放在抽屉里
- ▶ Version Plastic, set of 10
- ▶ Application As a rack for four electrode holders 50 or a palletø 115/148 mm.
- ▶ Note System racks can be stuck together without any gaps, for example, to be stored in drawers

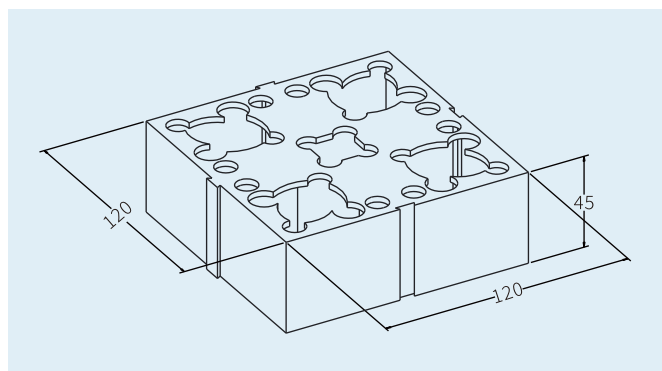

3A-300107 黑、红、蓝色电极储存胶盒
Electrode storage box (Black/Red/Blue)

- ▶ 规格 内置尺寸为54.7x54.7mm, 产品适用于50型电极座存放, 一款可放15个
- ▶ Version Inside size: 54.7x54.7mm, Can be used to storage 50 type electrode holders, One can put 15 pieces

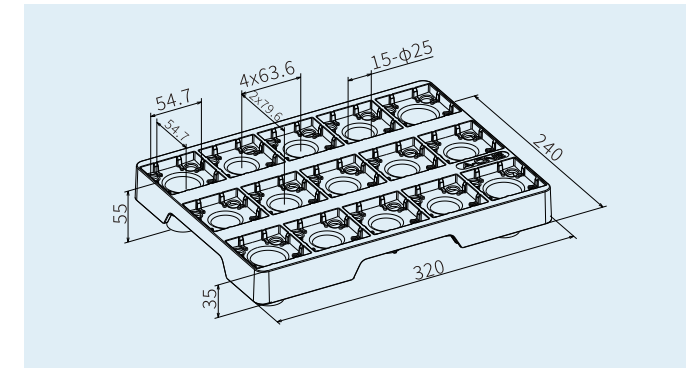

3A-400021 电极手推车
Electrode cart

- ▶ 规格 胶盒需另购
- ▶ 应用 可拆式手推车，包装运输方便，结构紧凑
- ▶ Version Plastic case supplied separately
- ▶ Application Electrode cart that can be disassembled. Convenient for packing and transportation, Robust structure

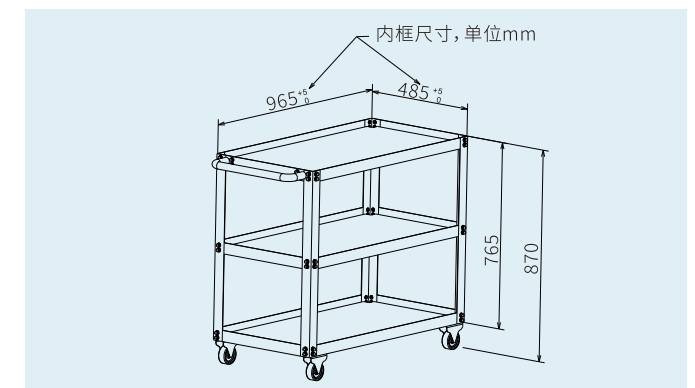

3A-400096 电极分中器
Electrode divider

- ▶ 规格 系统尺寸ITS100型卡盘或R型100型卡盘
- ▶ 应用 应用于EDM电极坯料分中
- ▶ 注意 卡盘需另购（适配3A-100901、3A-100061卡盘运用）
- ▶ Version ITS system size 100 chuck or R type chuck 100
- ▶ Application Used in the division of EDM electrode blanks
- ▶ Note Chuck supplied separately (compatible with chuck 3A-100901, 3A-100061)



3A-110023 实心夹头 $\varnothing 72$; 一套6个
Uniblack $\varnothing 72$; 6 pieces

- ▶ 规格 一套6个, 系统尺寸50mm, 不含拉钉
- ▶ 应用 安装各种形状的电极和工件
- ▶ 安装 根据需要钻连接孔
- ▶ 备注 承接非标定做
- ▶ Version Set of 6 units, System size 50mm. Without spigots
- ▶ Application To mount electrodes and workpieces of various shapes
- ▶ Mounting Attachment boreholes to be drilled according to requirements
- ▶ Note OEM Service available

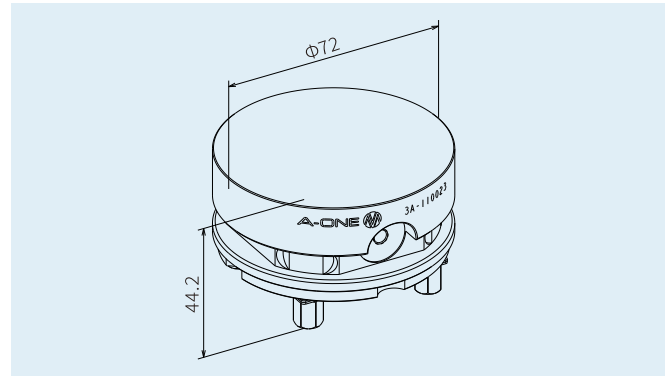

3A-110028 坯料夹头 $\varnothing 10/\varnothing 72$; 一套6个
Blank holder $\varnothing 10/\varnothing 72$; 6 pieces

- ▶ 规格 一套6个, 系统尺寸50mm, 不含拉钉
- ▶ 应用 夹持10mm的圆柱形工件
- ▶ 备注 承接非标订做
- ▶ Version Set of 6 units, system size 50. Without spigots
- ▶ Application To clamp cylindrical parts with $\varnothing 10$ mm
- ▶ Note OEM Service available

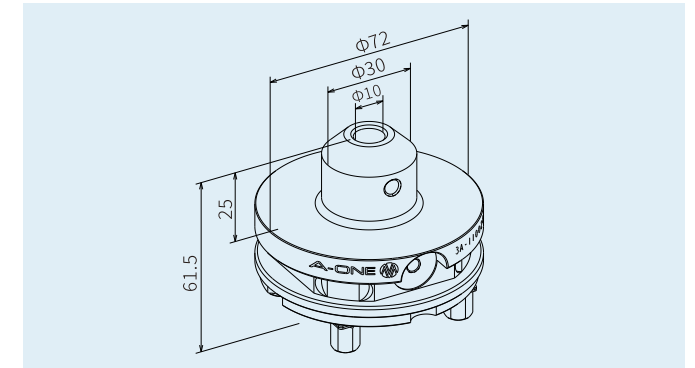

3A-110025 直槽夹头 $\varnothing 72$; 一套6个
Uniholder $\varnothing 72$, 6 pieces

- ▶ 规格 一套6个, 系统尺寸50mm, 不含拉钉
- ▶ 应用 安装尺寸最大至20mm的电极和工件
- ▶ 注意 承接非标定做
- ▶ Version Set of 6 units, system size 50. Without spigots
- ▶ Application To mount electrodes and workpieces with shaft of up to 20mm
- ▶ Note OEM Service available

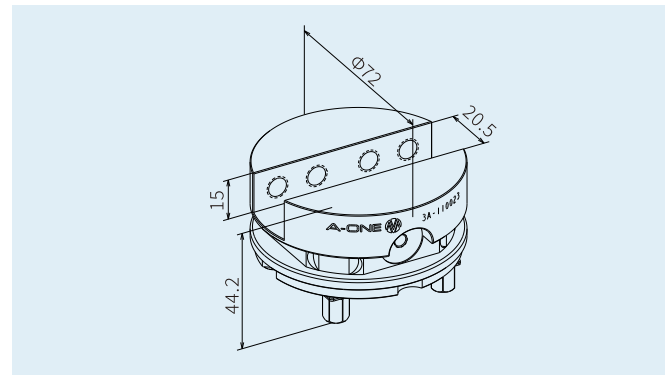

3A-110026 坯料夹头 $\varnothing 20/\varnothing 72$; 一套6个
Blank holder $\varnothing 72$; 6 pieces

- ▶ 规格 一套6个, 系统尺寸50mm, 不含拉钉
- ▶ 应用 夹持20mm的圆柱形工件
- ▶ 备注 承接非标订做
- ▶ Version Set of 6 units, system size 50mm. Without spigots
- ▶ Application To clamp cylindrical parts with $\varnothing 20$ mm
- ▶ Note OEM Service available

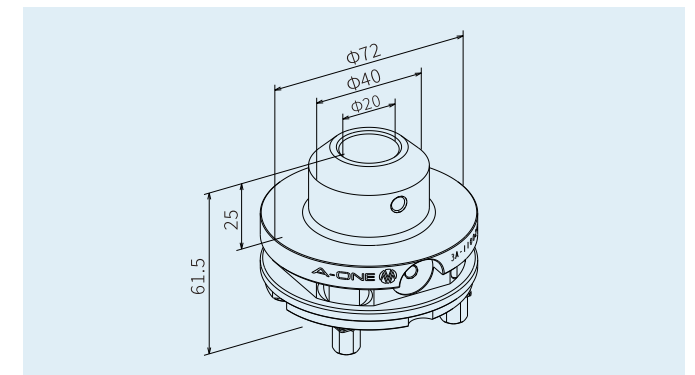

3A-110037 方孔夹头 $\varnothing 72-15$
Square holder $\varnothing 72-15$

- ▶ 规格 系统尺寸50mm, 不含夹紧拉钉
- ▶ 安装 安装尺寸最大至15mm的电极和工件
- ▶ 备注 承接非标订做
- ▶ Version System size 50mm, without spigot
- ▶ Application To mount electrodes and workpieces with shaft of up to square 15 mm
- ▶ Note OEM Service available

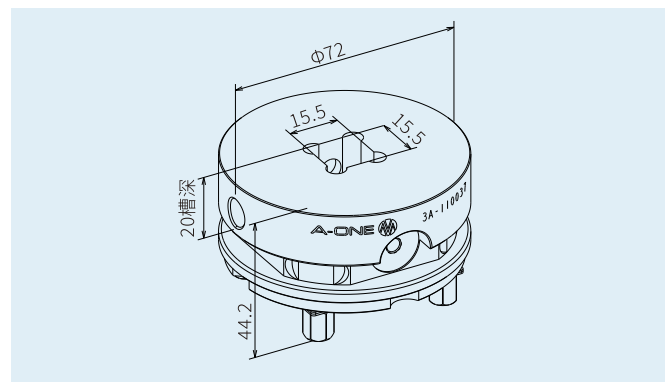

3A-110029 坯料夹头 $\varnothing 72$; 不带布孔; 一套6个
Blank holder $\varnothing 72$; Without borehole; 6 pieces

- ▶ 规格 一套6个, 系统尺寸50mm, 不含拉钉
- ▶ 应用 夹持圆柱形工件
- ▶ 安装 根据需要钻最大直径 $\varnothing 12$ mm的连接孔
- ▶ 备注 承接非标订做
- ▶ Version Set of 6 units, system size 50mm. Without spigots
- ▶ Application To clamp cylindrical parts
- ▶ Mounting Attachment borehole up to max $\varnothing 12$ mm to be drilled according to requirements
- ▶ Note OEM Service available

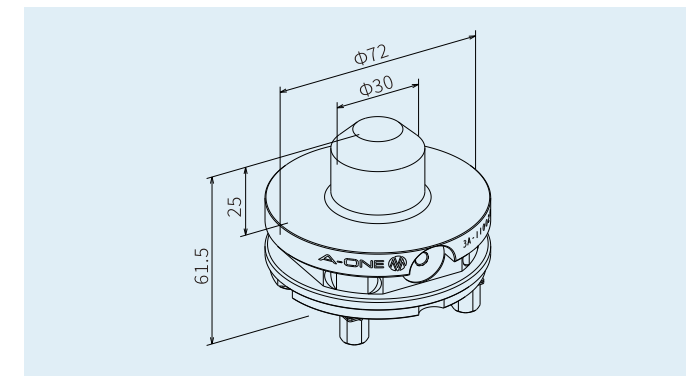

3A-110027 方孔夹头 $\varnothing 72$; 一套6个
Prisround $\varnothing 72$, 6 pieces

- ▶ 规格 一套6个, 系统尺寸50mm, 不含拉钉
- ▶ 应用 安装接杆尺寸最大至25mm的电极和工件
- ▶ 备注 承接非标订做
- ▶ Version Set of 6 units, system size 50mm. Without spigots
- ▶ Application To mount electrodes and workpieces with shafts of up to square 25mm
- ▶ Note OEM Service available

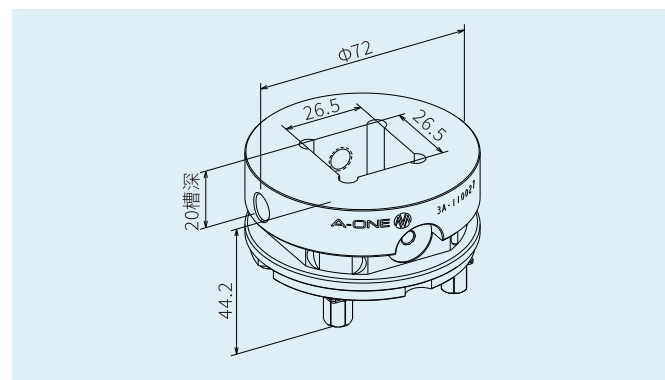

3A-110031 弹簧套筒夹头 $\varnothing 72$
Collet chuck holder $\varnothing 72$

- ▶ 规格 每个弹簧套筒夹头都配有夹紧拉钉, 系统尺寸50mm
- ▶ 应用 夹持圆柱形工件。夹持范围 $\varnothing 2$ mm- $\varnothing 20$ mm
- ▶ 注意 单独订购弹簧套筒
- ▶ Version One collet chuck holder with chucking spigot. System size 50mm
- ▶ Application To clamp cylindrical parts. Clamping range $\varnothing 2$ mm - $\varnothing 20$ mm
- ▶ Note Ordered collet chucks separately

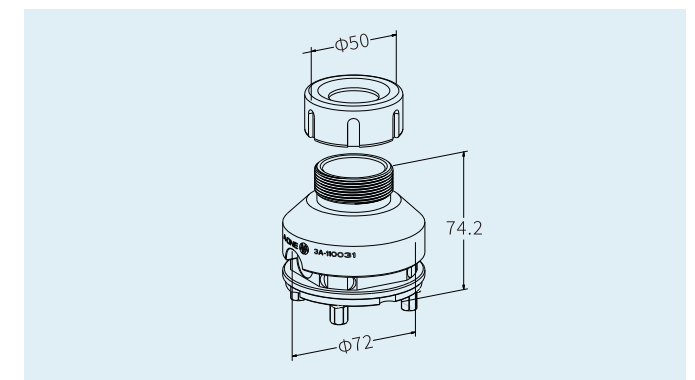

3A-110018 托板Ø148
Pallet Kit Ø148

- ▶ 规格 强力定位片, 中心孔周围无布孔, 有基准螺孔, ITS系统, 不含拉钉
- ▶ 应用 在切削加工中适用于工件的加工
- ▶ 安装 按需要
- ▶ Version Centering plate G Inox, Without boreholders apart from center borehole and borehole for reference bolt, ITS system, Without spigots.
- ▶ Application For workpieces machined in chip-cutting machining
- ▶ Mounting According to your preference

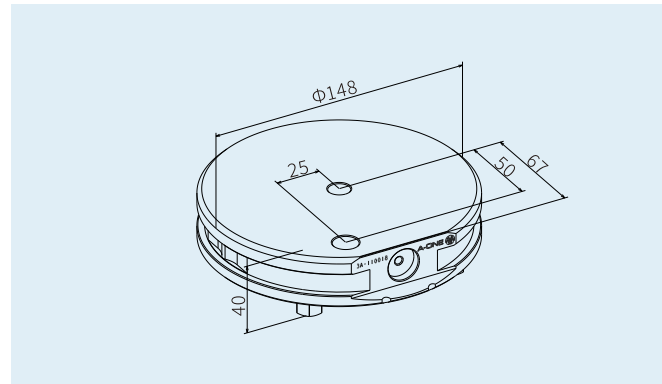

3A-110048 托板Ø148
Pallet Kit Ø148

- ▶ 规格 钢, 耐腐蚀, 90型定位片, 托板集成中心定位系统, ITS系统, 不含拉钉
- ▶ 应用 用于所有A-ONE强力卡盘和生产型卡盘。在切削加工过程中适用于工件和夹具
- ▶ 安装 用M8螺钉穿过托板, 或用M10螺钉穿过坯料
- ▶ Version Steel, corrosion-resistant. Centering plate 90 M8, Centering integrated in the pallet, ITS system, Without spigots.
- ▶ Application For use on all A-one Power Chuck and Production Chuck. To accommodate workpieces and fixtures in chip-cutting machining processes.
- ▶ Mounting Through pallet with M8 bolts or through blank with M10 bolts.

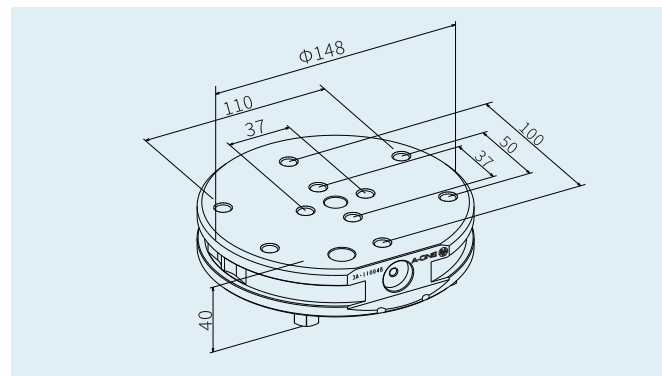

3A-110084 托板Ø148
Pallet Kit Ø148

- ▶ 规格 标准型, ITS系统, 强力定位片, 不含拉钉
- ▶ 应用 适用于切削加工的工件和夹具
- ▶ 安装 用M8螺钉穿过托板或用M10螺钉穿过坯料
- ▶ Version Standard type, ITS system, Centering plate 90 M8 Without spigots
- ▶ Application To accommodate workpieces and fixtures in chip-cutting machining processes
- ▶ Mounting Through pallet with M8 bolts or through blank with M10 bolts

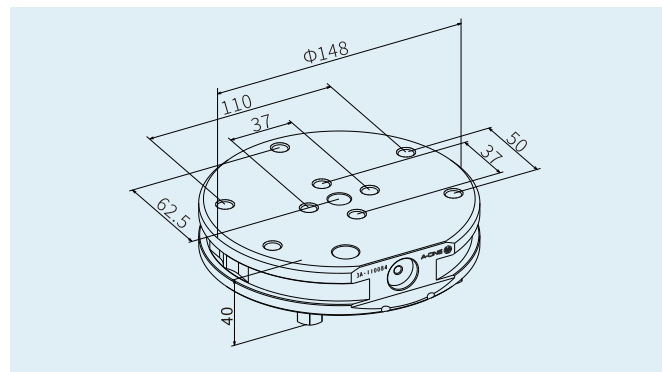

3A-300001 方形25×25mm电极夹头
Square 25×25mm electrode holder

- ▶ 规格 ITS系统尺寸50
- ▶ 应用 电火花和线切割
- ▶ Version ITS system size 50
- ▶ Application EDM/WEDM

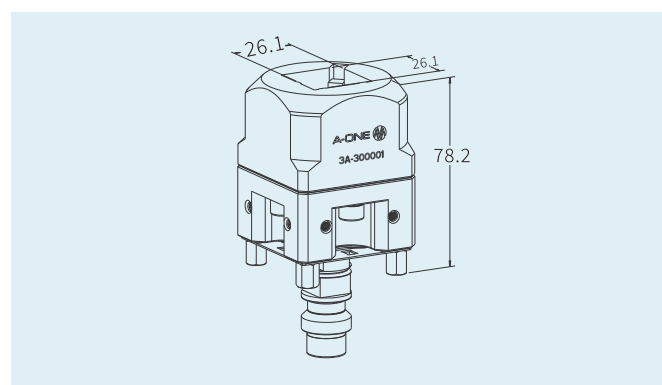

3A-300002 方形15×15mm电极夹头
Square 15×15 electrode holder

- ▶ 规格 ITS系统尺寸50
- ▶ 应用 电火花和线切割
- ▶ Version ITS system size 50
- ▶ Application EDM/WEDM

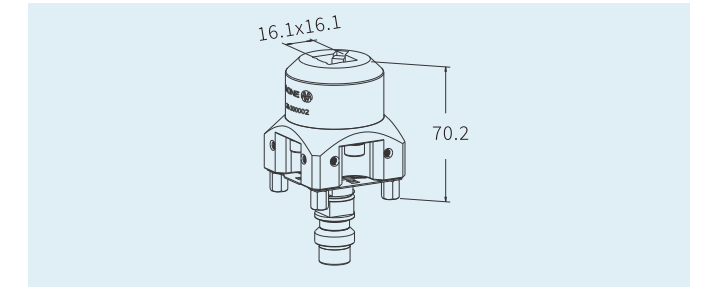

3A-300022 弹簧套筒夹头
Collet chuck holder 50

- ▶ 规格 系统尺寸50, 包括扳手, 弹簧套筒需另购
- ▶ 应用 夹持最大至φ20mm的圆形料件
- ▶ 弹簧套筒 φ2-φ20mm 同心度: 普通级0.02mm, A级0.01mm 及UP级0.005mm
- ▶ Version System size 50, incl wrench, set of collet chucks to be separately supplied.
- ▶ Application For round material up to φ20mm.
- ▶ Set of collet chucks φ2-φ20mm The concentricity: General class 0.02mm, A class 0.01mm and UP class 0.005mm

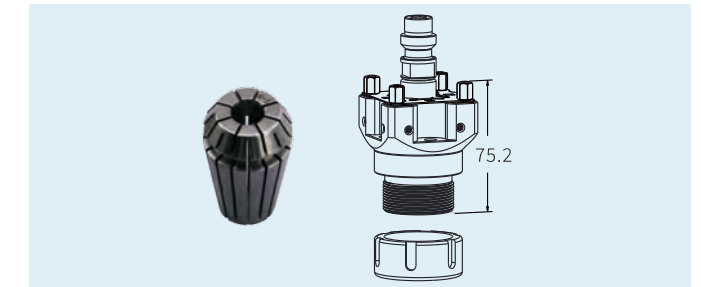

3A-300052 电极夹头Ø1-Ø10mm
Electrode collet Ø1-Ø10mm

- ▶ 规格 配有扳手, 夹持范围Ø1-10mm, 中心夹持精度0.05mm
- ▶ 应用 适用于EDM电极快速夹持
- ▶ Version Including wrench, clamping size: Ø1-10mm Centering clamping precision: 0.05mm
- ▶ Application Suited for clamping EDM electrode quickly

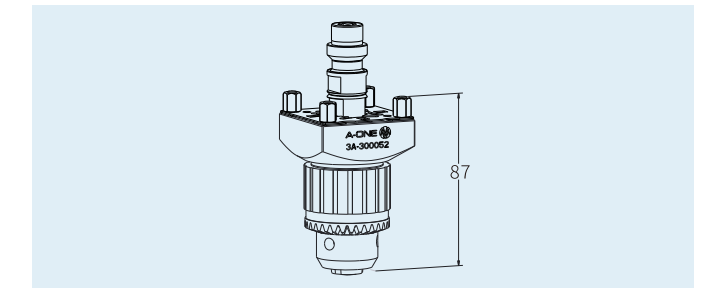

3A-300053 电极夹头Ø5-Ø20mm
Electrode collet Ø5-Ø20mm

- ▶ 规格 配有扳手, 夹持范围Ø5-20mm, 中心夹持精度0.05mm
- ▶ 应用 适用于EDM电极快速夹持
- ▶ Version Including wrench, clamping size: Ø5-Ø20mm Centering clamping precision: 0.05mm
- ▶ Application Suited for clamping EDM electrode quickly

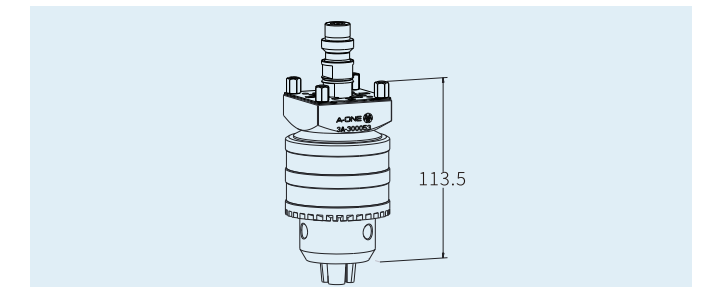

磁力托板
Magnetic plate

- ▶ 规格 装强力定位片3A-400001和拉钉, 配A-ONE卡盘3A-100050强力卡盘等使用
- ▶ 应用 夹持工件, 用于平面磨及EDM放电加工
- ▶ 吸引力 12kgf/平方厘米
- ▶ 注意 不含卡盘; 承接非标尺寸定做
- ▶ Version With strong positioning plate 3A-400001 and screws, with A-ONE 3A-110030 such as the use of powerful chuck Clamping workpiece, used for grinding plane and EDM sinking
- ▶ Application Clamping workpiece, used for grinding plane and EDM sinking
- ▶ Attraction 12kgf/cm²
- ▶ Note Without chuck; Size can be customized

编号 Model No	规格 Specification (L*W*Hmm)	极距mm Pole distance	平面度 Flatness	净重(kg) Net weight
3A-110201	150*150*45	0.5+1.5	0.02	8
3A-110202	220*150*50	0.5+1.5	0.02	13
3A-110203	300*150*50	0.5+1.5	0.02	18
3A-110204	250*250*50	0.5+1.5	0.02	25

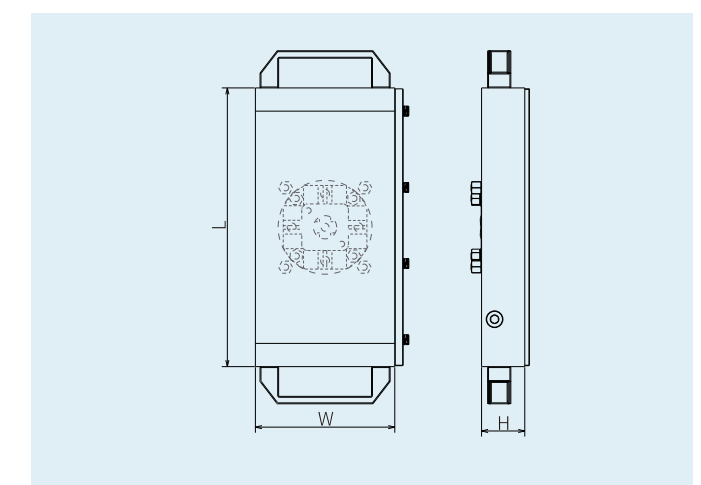



- 1、可移动的上部用作误差补偿
Movable upper part for error compensation
- 2、锁紧球槽
Groove for ball lock
- 3、与料仓的接合平面
Bonding plane with silo
- 4、O形密封圈
Groove for O-ring seal
- 5、握爪平面
Flats for gripper

手动 Manual

自动 Automatic

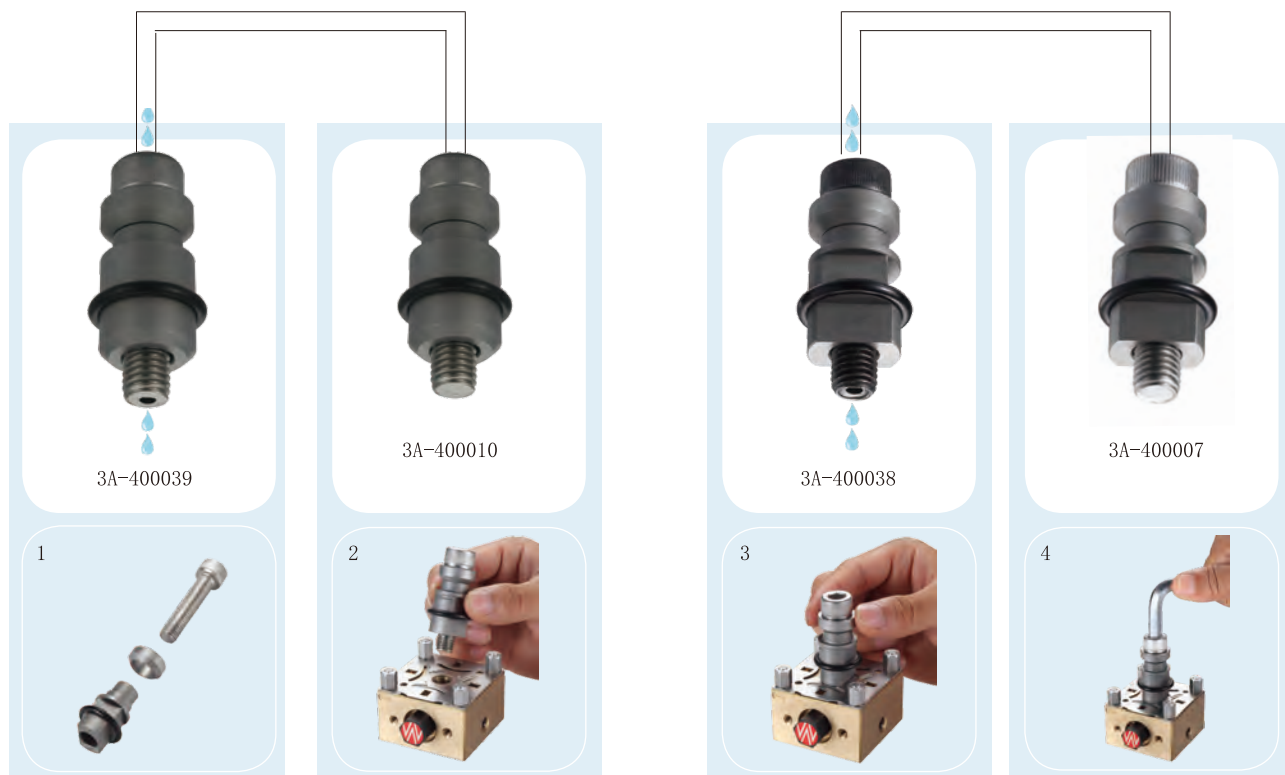

3A-400005 拉钉组合
Chucking spigot F/M production

- ▶ 规格 固定型，手动。螺钉12.9，可带中心冲洗孔
- ▶ 应用 用于切削过程中的托板
- ▶ Version Fixed type, manual. Bolt 12.9, with flushing hole
- ▶ Application For pallets for chip-cutting machining processes

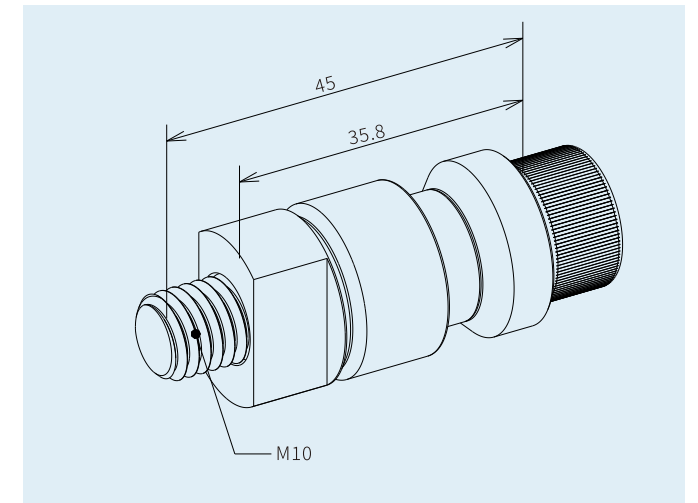

3A-400083 四方自动拉钉
Chucking Spigot F/A Inox

- ▶ 规格 固定型，自动，不锈钢螺钉，无中心冲洗孔
- ▶ 应用 适用于电极库
- ▶ 优点 可双向抓取
- ▶ Version Fixed type, automatic, stainless steel Bolt, without flushing hole
- ▶ Application Suited for robot system cutting force
- ▶ Advantage Can be clamp from double sides

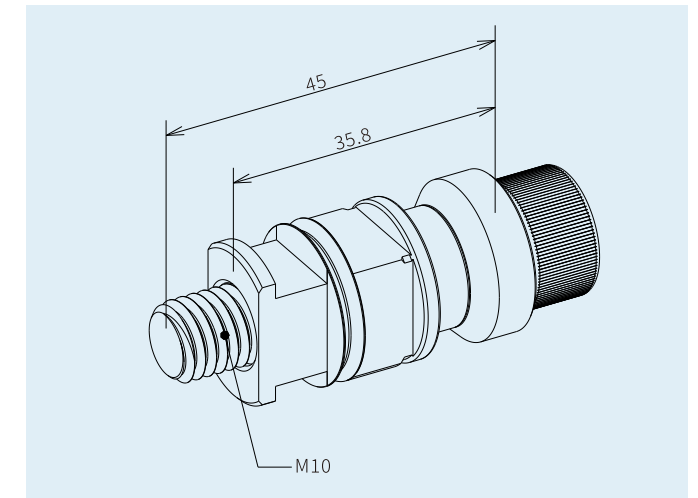

3A-400010 拉钉组合
Chucking spigot F/M production

- ▶ 规格 固定型，手动。螺钉12.9（无中心冲洗孔）
- ▶ 应用 用于切削过程中的托板
- ▶ Version Fixed type, manual. Bolt 12.9, without flushing hole
- ▶ Application For pallets for chip-cutting machining processes

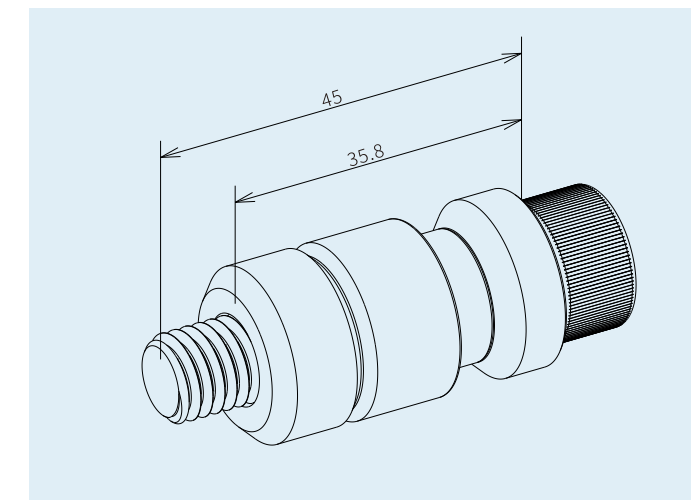

3A-400039 拉钉组合
Chucking spigot F/M EDM for flushing

- ▶ 规格 固定型, 手动。螺钉 带中心冲洗孔
- ▶ 应用 用于切削过程中的托板
- ▶ Version Fixed type, manual. Bolt 12.9, with flushing hole
- ▶ Application For pallets for chip-cutting machining processes

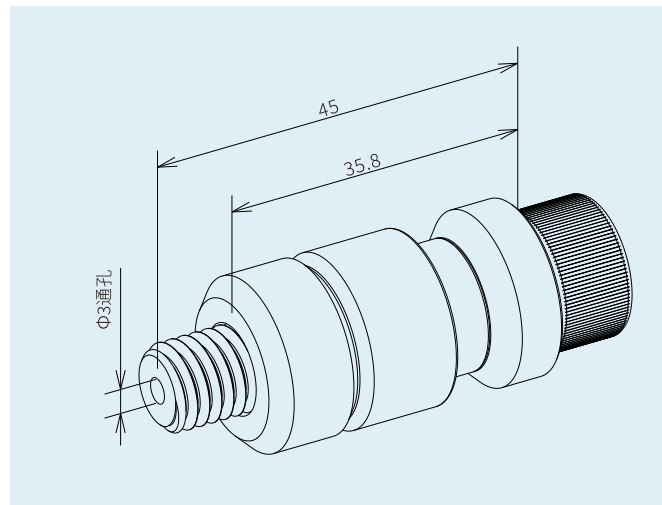

3A-400007 拉钉组合
Chucking spigot F/A Inox

- ▶ 规格 固定型, 自动。不锈钢螺钉, 无中心冲洗孔
- ▶ 应用 适用于电极库
- ▶ Version Fixed type, automatic. Bolt stainless, without flushing hole
- ▶ Application On all holders used on electrode library

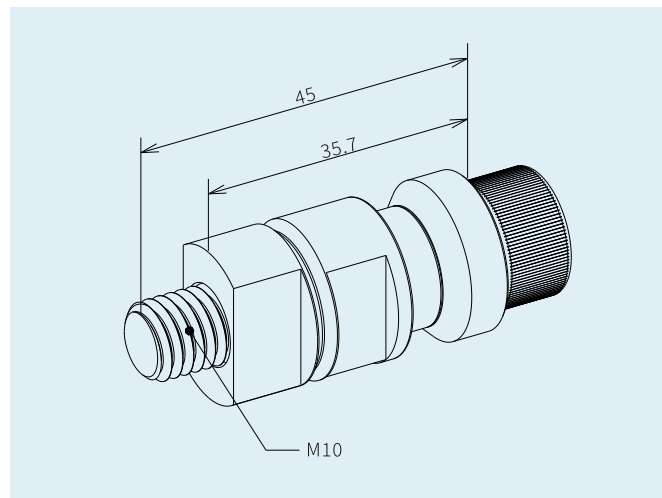

3A-400038 拉钉组合
Chucking spigot F/A EDM M10*45 for flushing

- ▶ 规格 固定型, 自动。不锈钢螺钉, 带中心冲洗孔
- ▶ 应用 用于切削过程中的托板
- ▶ Version Fixed type, automatic. Bolt stainless, with flushing hole
- ▶ Application For pallets for chip-cutting machining processes

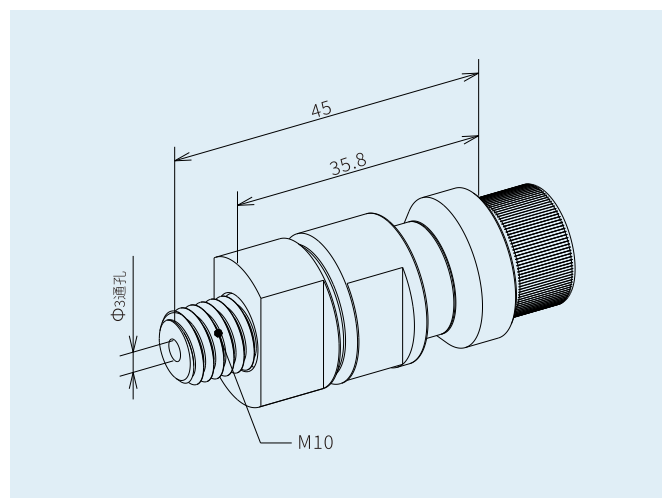

A-ONE EDM工具

A-ONE EDM tools

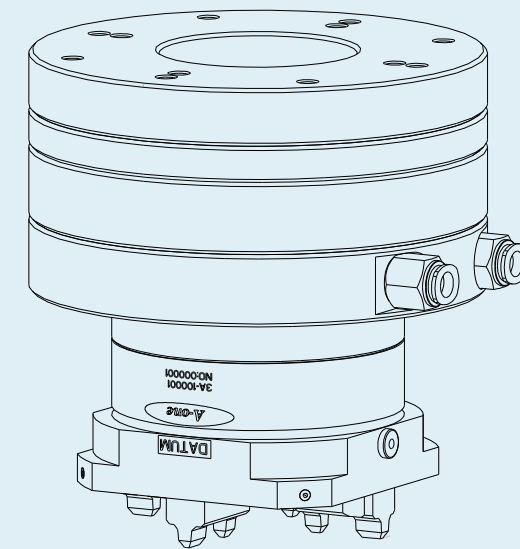

EDM工具
EDM tools

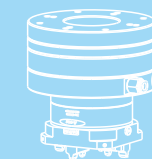

P.045~P.046

延长杆
Extention chuck



P.047~P.048

方形电极系统和十字夹头
Square electrode clamping system and system plus

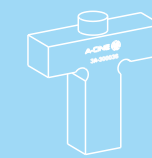

P.049~P.053

3A-300004 千秋架改装板
Adapter plate

- ▶ 规格 表面发黑, M6螺丝过槽
- ▶ 应用 千秋架与ITS卡盘连接板
- ▶ Version Black coated, M6 screws passing slot
- ▶ Application Chiaki frame and ITS chuck plate

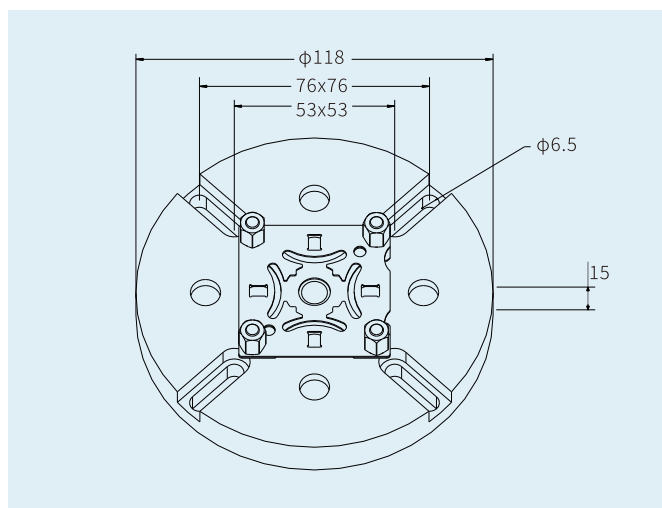

3A-300010 千秋架
Changeable EDM chuck

- ▶ 规格 可在X, Y, Z 多向微调精度
可由标准加工转换为普通加工
- ▶ 应用 适用于电火花成型机, 快捷转换
- ▶ Version X, Y, Z axis precise adjustment. Easy and quick change from standard process to normal process
- ▶ Application To be used on EDM for quick change

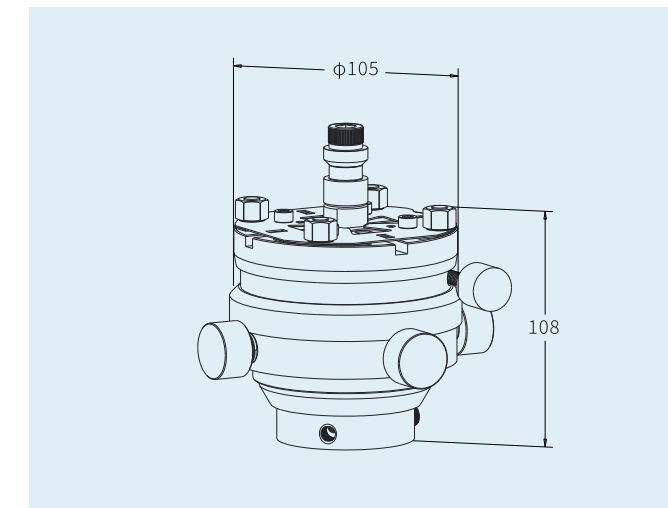

3A-300016 EDM卡盘安装套装
Adapter plate for auto chuck

- ▶ 规格 按客户机床定制, 卡盘需另购, 订购时可根据下表进行选配
如需订货, 请参考示意图提供以下数据:
与机头对应的安装孔的大小 (φZ/MZ) 和相对位置 (X, Y)
是否需要绝缘板组件 P1、P2、P3
- ▶ 应用 适用于电火花成型机床, 直接安装在机头上
- ▶ Application Customized according to customer's machine. Chuck supplied separately. Choose the chuck according to the table below when ordering.
If customized, refer to drawings and data.
Diameter and number of holes (ØZ / MZ) on EDM head and their X, Y positions.
Whether insulating plates are needed or not, P1, P2, P3
- ▶ Version To be directly mounted on EDM head.

选配卡盘 Optional chuck	气动 Pneumatic	手动 Manual
E型 E type	3A-100001、3A-100901	3A-100003
R型 R type	3A-100061	3A-100903

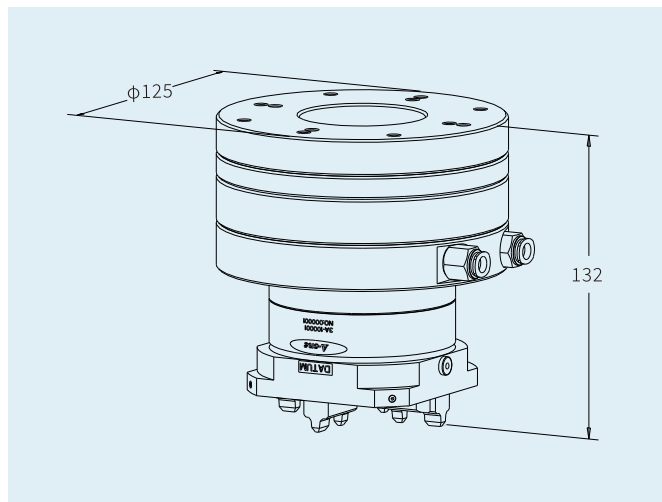

3A-300008 EDM活动卡盘
Adjustable EDM holder

- ▶ 规格 可在X, Y, Z多向微调精度。可由标准加工转换为普通加工, 卡盘需另购
- ▶ 应用 适用于电火花成型机, 快捷转换
- ▶ Version X, Y, Z axis precise adjustment. Easy and quick change from standard process to normal process. chuck supplied separately
- ▶ Application To be used on EDM for quick change

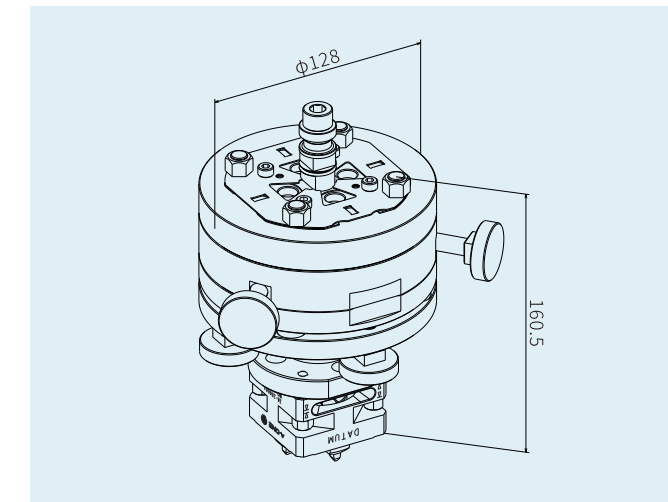

3A-300058 220V 延长卡盘
220V Extension chuck

- ▶ 规格 垂直延长200mm, 配80型气动卡盘, 中心角度偏差小于0.006mm
- ▶ 应用 适用于EDM, Z向行程延伸
- ▶ Version Extending 200mm vertically. Matching 80 style pneumatic chuck. The centering angel tolerance less than 0.006mm
- ▶ Application Suited for EDM machine, Z axis extension

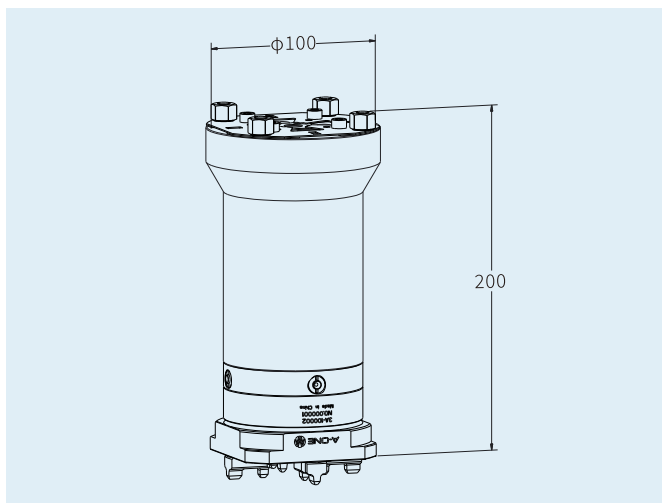

3A-200003 延伸臂 UnoSe
Extension arm UnoSet

- ▶ 规格 可由垂直加工转为水平式加工
加工方便、快捷
含卡盘
- ▶ 应用 适用于各种线割机, 电火花. 可配合各式卡盘使用.
- ▶ 净重 1KG
- ▶ Version Can be changed from vertical position to horizontal position
Easy and quick change
With chuck
- ▶ Application To be used on all types of wire-cut EDM or EDM
Can be used with all kinds of chucks.
- ▶ Net weight 1KG

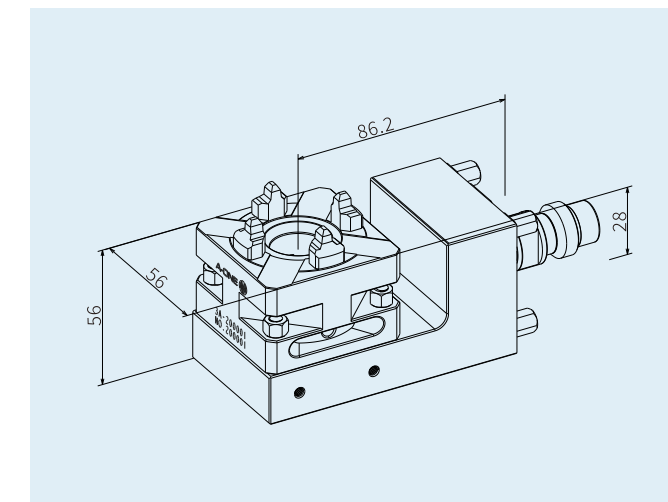

3A-300017 EDM 延长杆
Extention chuck

- ▶ 规格 56X56X150mm
- ▶ 应用 用于汽车或电器模具等深型腔电蚀加工
- ▶ Version 56X56X150mm
- ▶ Application To be used in deep cavity cutting for automotive molds or electrical molds

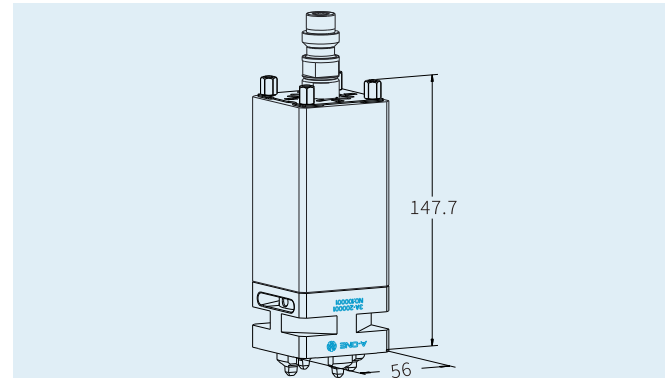

3A-300048 50V 延长杆
50V Extension chuck

- ▶ 规格 Z 向延长 50mm, 系统尺寸 50
- ▶ 应用 适用于 EDM
- ▶ Version Z axis extend 50mm, system size 50
- ▶ Application Suited for EDM machine

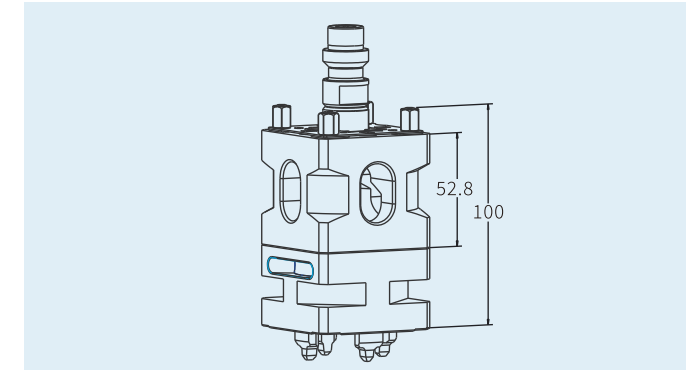

3A-300018 EDM 延长杆
Extention chuck

- ▶ 规格 56X56X200mm
- ▶ 应用 用于汽车或电器模具等深型腔电蚀加工
- ▶ Version 56X56X200mm
- ▶ Application To be used in deep cavity cutting for automotive molds or electrical molds

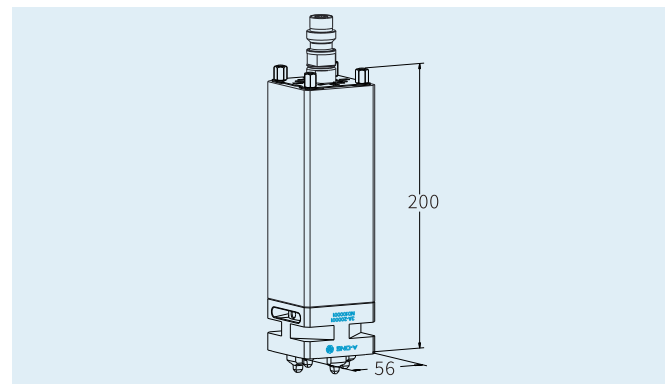

3A-300093 150H 延长杆
150H Extension chuck

- ▶ 规格 中心水平延长150mm
- ▶ 应用 适用于火花机
- ▶ Version Center horizontal extend 150mm
- ▶ Application Suited for EDM machine

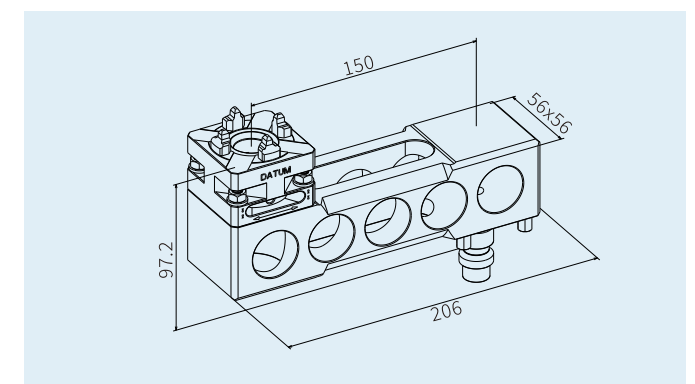

3A-300042 200V 延长杆
200V Extension chuck

- ▶ 规格 硬质钢, 耐腐蚀, 结构稳定
- ▶ 应用 适用于火花机 Z 轴延长或大型模具深型腔电蚀加工
- ▶ Version Alloy steel, Corrosion-resistant, Robust structure
- ▶ Application Can be extended vertically or deep cavity machining of big size mold

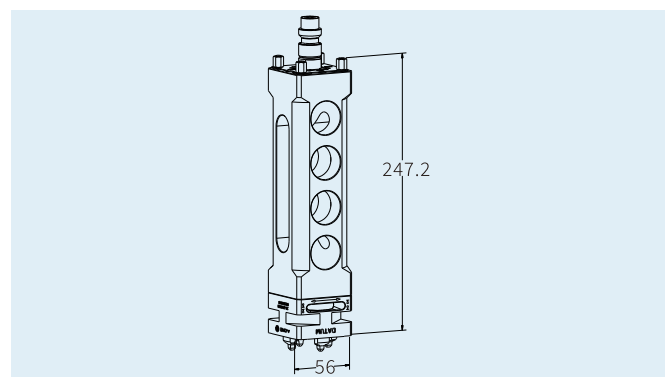

3A-300102 100H 延长杆
100H Extension Chuck

- ▶ 规格 系统尺寸 50, 钢, 中心水平延长100mm
- ▶ 应用 适用于装有快换卡盘的EDM主轴
- ▶ 注意 电极重量不大于5kg
- ▶ Version System size 50, Steel, Center horizontal extend 100mm
- ▶ Application Suited for EDM spindle with rapid-action chuck
- ▶ Note Electrode weight can't be more than 5kg

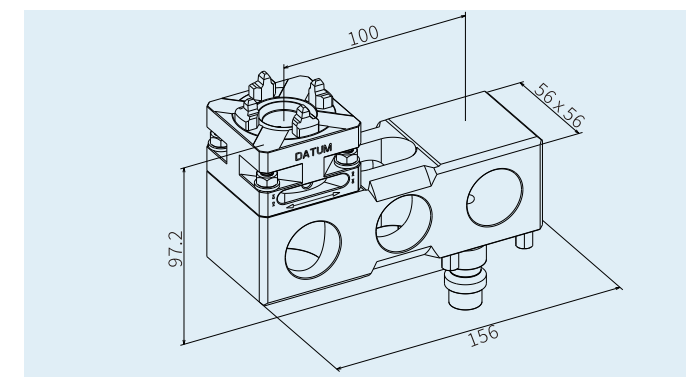

3A-300043 100V 延长杆
100V Extension chuck

- ▶ 规格 硬质钢, 耐腐蚀, 结构稳定
- ▶ 应用 适用于火花机 Z 轴延长或大型模具深型腔电蚀加工
- ▶ Version Alloy steel, Corrosion-resistant, Robust structure
- ▶ Application Can be extended vertically or deep cavity machining of big size mold

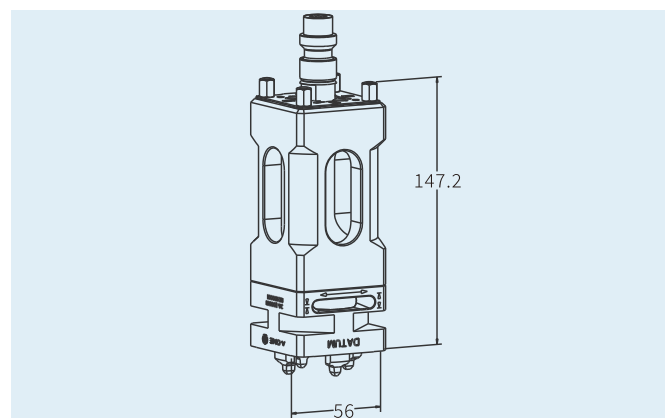

3A-300117 角度旋转夹头
Angle rotating chuck

- ▶ 分度 0 - 90°, 每齿5°
- ▶ 规格 ITS50接口, ER16筒夹 (φ1.0-φ10)
- ▶ 应用 EDM机床, 电极摆角度放电
- ▶ 注意 不可用于铣削, 标准产品不含ER筒夹
- ▶ Graduation 0-90°, 5° per tooth
- ▶ Version ITS50 interface, ER16 collet (φ1.0-10mm)
- ▶ Application EDM machine. The electrode discharges at an angle.
- ▶ Note Not for milling, the standard product does not contain ER collets.

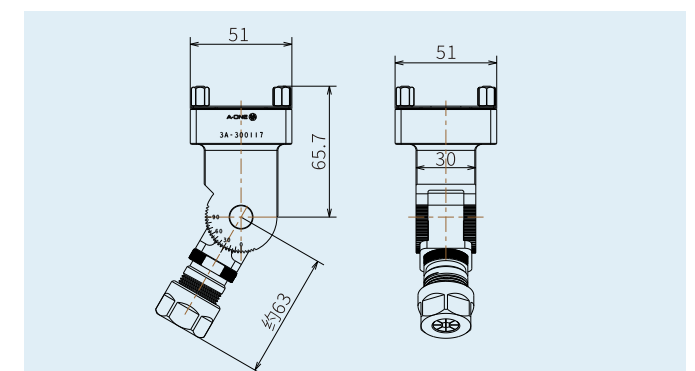

3A-300050 角度旋转卡盘
Angled damping unit UnoSet for quick chuck 50

- ▶ 适用于线切割或电火花
- ▶ 50 型手动卡盘，游标尺设定角度尺寸
- ▶ 不锈钢（淬硬）
- ▶ 最大负荷：6kg；最大工件尺寸 100mm
- ▶ 有冲洗连接孔
- ▶ Can be used for EDM or WEDM
- ▶ 50 type manual chuck can be mounted. Angle to be set with vernier
- ▶ Stainless steel, hardened
- ▶ Maximum load: 6kg, Maximum workpiece size: 100mm
- ▶ Flushing hole connection

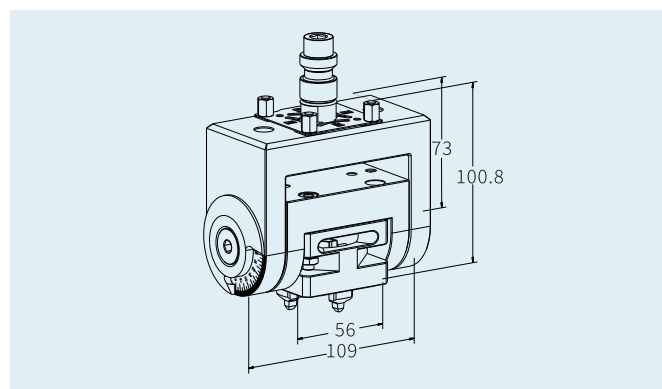

钨铜螺纹电极
Copper tungsten threaded electrode

材料 Material	成分 Composition (by wt)	密度 Density (g/cm ³)	电导率 Electrical conductivity (%IACS)	硬度 Hardness (HRB)
WD™ 10075	Tungsten: 70% (钨含量 70%) Copper: 30% (铜含量 30%)	14.6	38	94

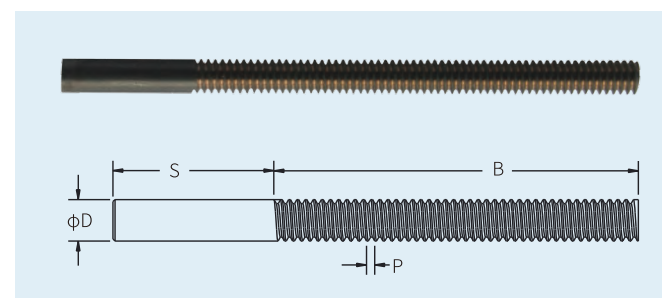

型号 M (Model)	规格 Specifications	牙距 P (Pitch)	柄径 D (Outer diameter)	柄长 S (Shank length)	牙长 B (Thread length)
3A-300061	M3	0.50	2.20	15	35
3A-300062	M4	0.70	3.00	15	55
3A-300063	M5	0.80	3.70	25	55
3A-300064	M6	1.00	4.50	25	55
3A-300068	M8	1.25	6.30	25	55-75
3A-300069	M10	1.50	8.00	25	55-75
3A-300070	M12	1.75	9.70	25	55-75
3A-300071	M14	2.00	11.50	25	55-75
3A-300072	M16	2.00	13.50	25	55-75
3A-300073	M18	2.50	15.00	25	55-75
3A-300074	M20	2.50	17.00	25	55-75

3A-300036 方形25校正规
Square 25 alignment rail

- ▶ 规格 钢，硬质，磨削
- ▶ 应用 测量夹头与 ITS 系统的同轴度和角度精度
- ▶ Version Steel, hardened, ground
- ▶ Application Testing of concentricity and angular accuracy of holder to ITS system

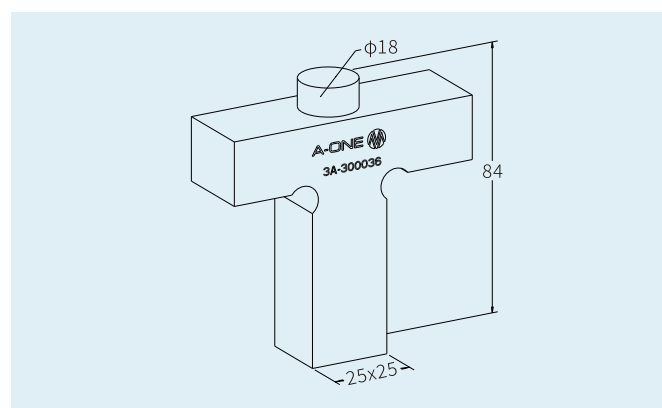

3A-300037 方形15校正规
Square 15 alignment rail

- ▶ 规格 钢，硬质，磨削
- ▶ 应用 测量夹头与 ITS 系统的同轴度和角度精度
- ▶ Version Steel, hardened, ground
- ▶ Application Testing of concentricity and angular accuracy of holder to ITS system

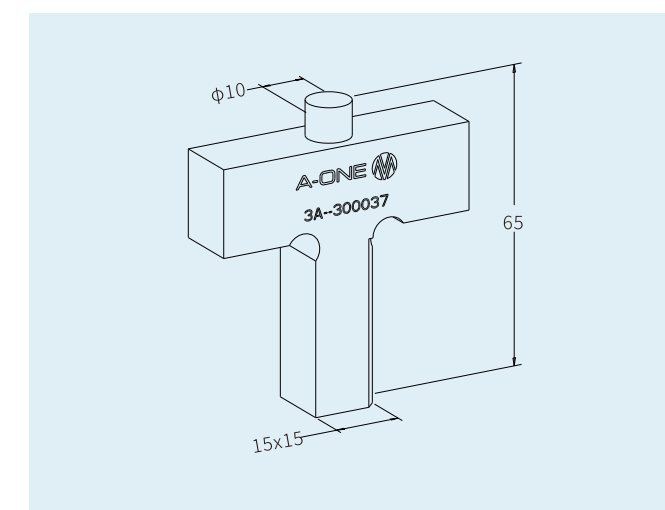

3A-300013 直夹头25 x 25 x 65mm
Holder straight 25X25X65mm

- ▶ 规格 钢，硬质，磨削。定位面25mm，包括螺钉
- ▶ 应用 用于铜质或石墨电极
- ▶ Version Steel, hardened, ground. Centering profile 25mm Holder incl. bolt
- ▶ Application For electrodes of copper or graphite

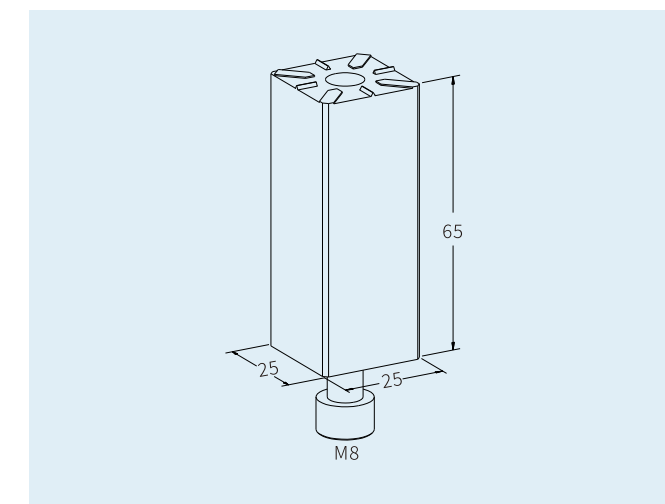

3A-300014 直夹头 25X25X110mm
Holder straight 25X25X110mm

- ▶ 规格 钢，硬质，磨削。定位面25mm，包括螺钉
- ▶ 应用 用于铜质或石墨电极
- ▶ Version Steel, hardened, ground. Centering profile 25mm Holder incl. bolt
- ▶ Application For electrodes of copper or graphite

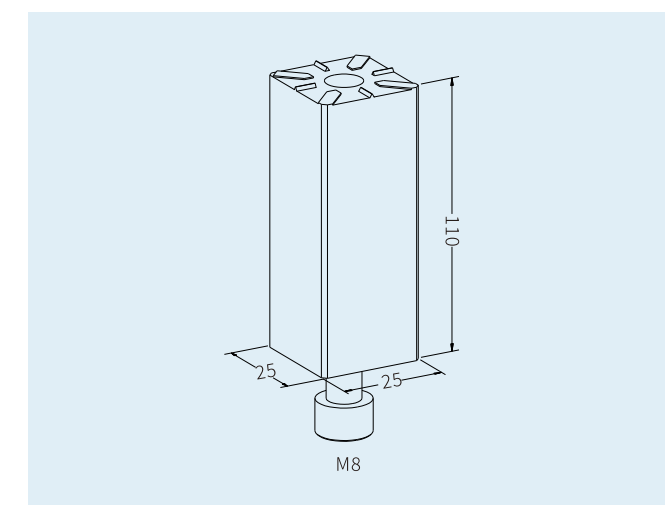

方形电极系统和十字夹头
Square electrode clamping system and system plus

3A-300083 直夹头 15 x 15 x 37mm
Holder straight 15 x 15 x 37mm

- ▶ 规格 钢, 硬质, 磨削。定位面15mm。包括螺钉
- ▶ 安装 用于铜质或石墨电极, 可根据提供的说明进行安装
- ▶ Version Steel, hardened, ground. Centering profile 15 mm. Holder incl bolt
- ▶ Application For electrodes of copper or graphite Fitting according to supplied instructions

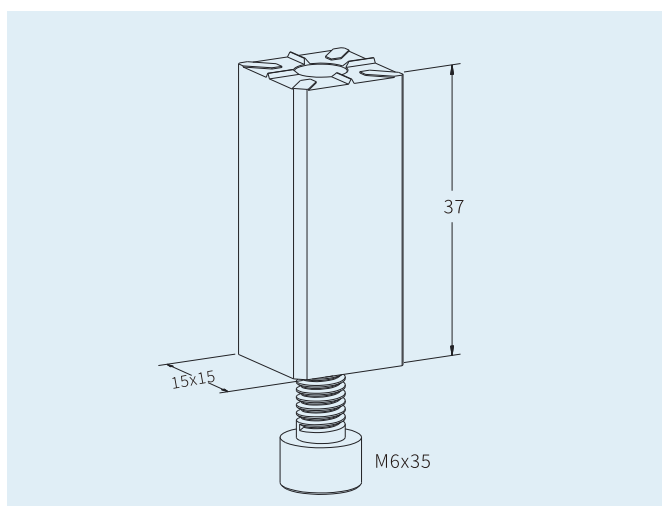

3A-300081 角夹头 15 x 15 x 50mm
Angle holder 15 x 15 x 50mm

- ▶ 规格 钢, 硬质, 磨削。定位面15mm。包括螺钉
- ▶ 应用 用于铜质或石墨电极, 可根据提供的说明进行安装
- ▶ Version Steel, hardened, ground. Centering profile 15mm. Holder incl. bolt
- ▶ Application For electrodes of copper or graphite Fitting according to supplied instructions

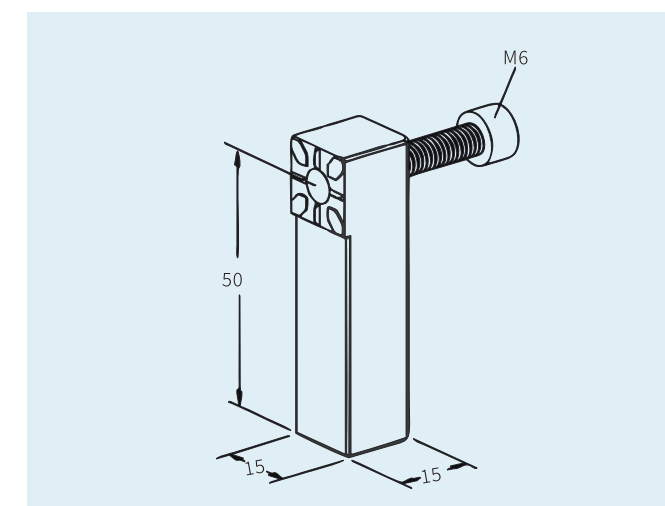

3A-300100 直夹头 15 x 15 x 57mm
Holder straight 15 x 15 x 57mm

- ▶ 规格 钢, 硬质, 磨削。定位面15mm。包括螺钉
- ▶ 安装 用于铜质或石墨电极, 可根据提供的说明进行安装
- ▶ Version Steel, hardened, ground. Centering profile 15 mm. Holder incl. bolt
- ▶ Application For electrodes of copper or graphite Fitting according to supplied instructions

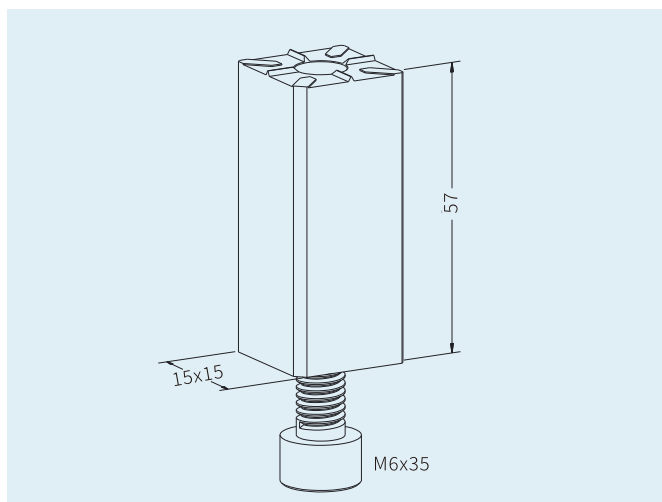

3A-300079 十字模, 尺寸15
Prism die, size 15

- ▶ 规格 钢, 硬质, 磨削。模压面15mm
- ▶ 应用 在坯料上压定心十字槽
- ▶ Version Steel, hardened, ground. Embossed profile 15mm
- ▶ Application Embossing of centering prisms in blanks

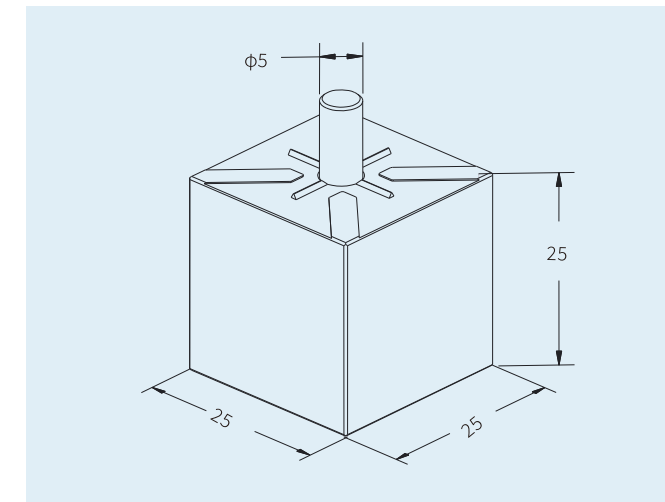

3A-300057 角夹头 25 x 25 x 90mm
Angle holder 25 x 25 x 90mm

- ▶ 规格 钢, 硬质, 磨削。定位面25mm。包括螺钉
- ▶ 应用 用于铜质或石墨电极, 可根据提供的说明进行安装
- ▶ Version Steel, hardened, ground. Centering profile 25 mm. Holder incl. bolt
- ▶ Application For electrodes of copper or graphite Fitting according to supplied instructions

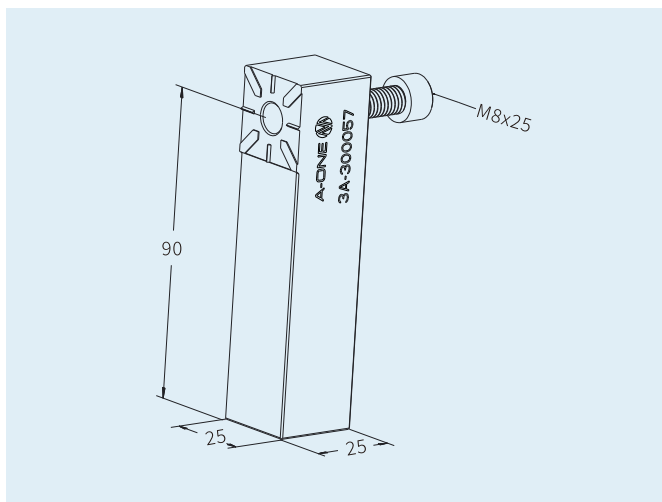

3A-300080 十字模, 尺寸25
Prism die, size 25

- ▶ 规格 钢, 硬质, 磨削。模压面25mm
- ▶ 应用 在坯料上压定心十字槽
- ▶ Version Steel, hardened, ground. Embossed profile 25mm
- ▶ Application Embossing of centering prisms in blanks

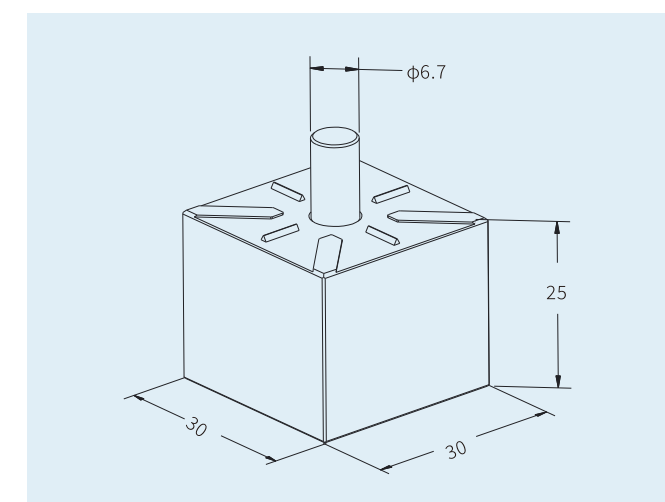

3A-300075 方形15 电极坯料
Square 15 electrode blank

- ▶ 规格 一套40个, 电火花加工用铜材, 拉伸成形
- ▶ 应用 边长最大至15mm见方的电极坯料
- ▶ Version Set of 40 blanks. EDM copper, drawn profile
- ▶ Application Blank for electrodes of up to 15mm square

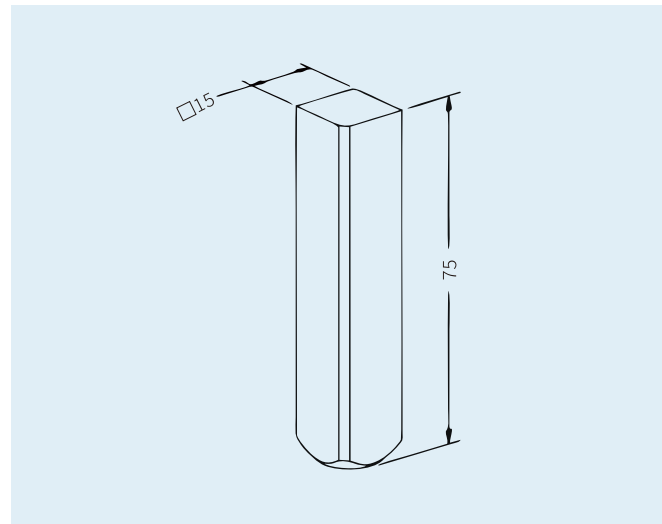

3A-300076 方形25 电极坯料25 x 25 x 80mm
Square 25 electrode blank

- ▶ 规格 一套24个, 电火花加工用铜材, 拉伸成形
- ▶ 应用 边长最大至25mm 见方的电极坯料
- ▶ Version Set of 24 blanks. EDM copper, drawn profile
- ▶ Application Blank for electrodes of up to 25 mm edge square

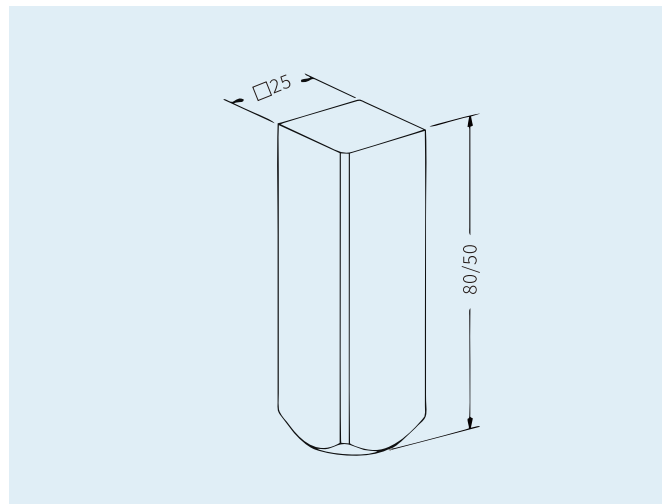

3A-300077 方形15 电极柄
Square 15 electrode shaft

- ▶ 规格 一套40个, 冷拉钢
- ▶ 应用 用于焊接或粘接到铜质或石墨电极坯料上
- ▶ Version Set of 40 shafts, drawn steel
- ▶ Application To solder or bond to copper or graphite electrode blanks

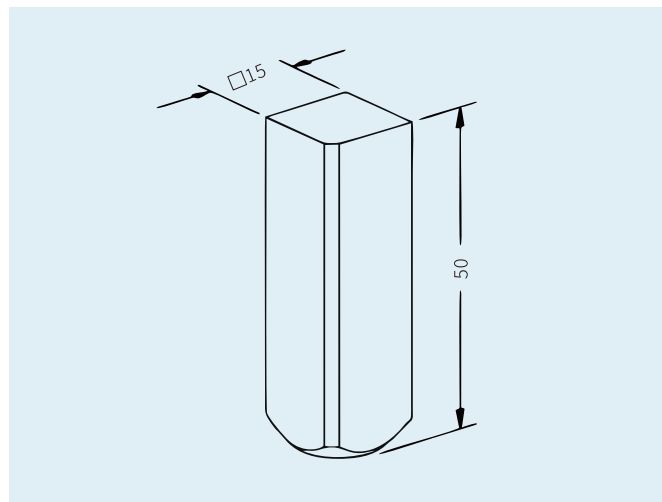

A-ONE 测量和控制元件

A-ONE Measurement and control componets

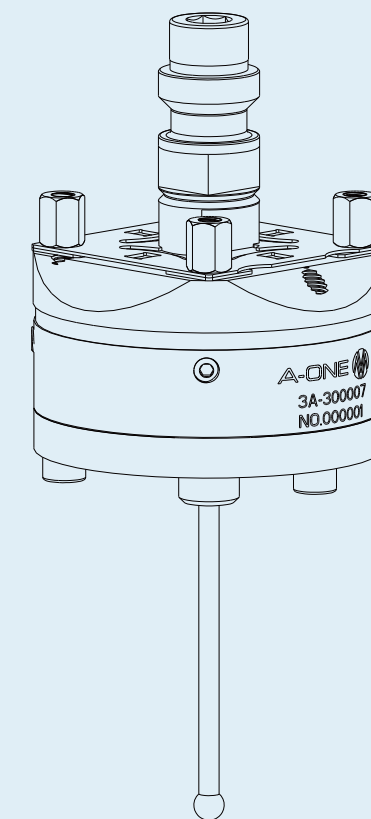

P.055~P.060

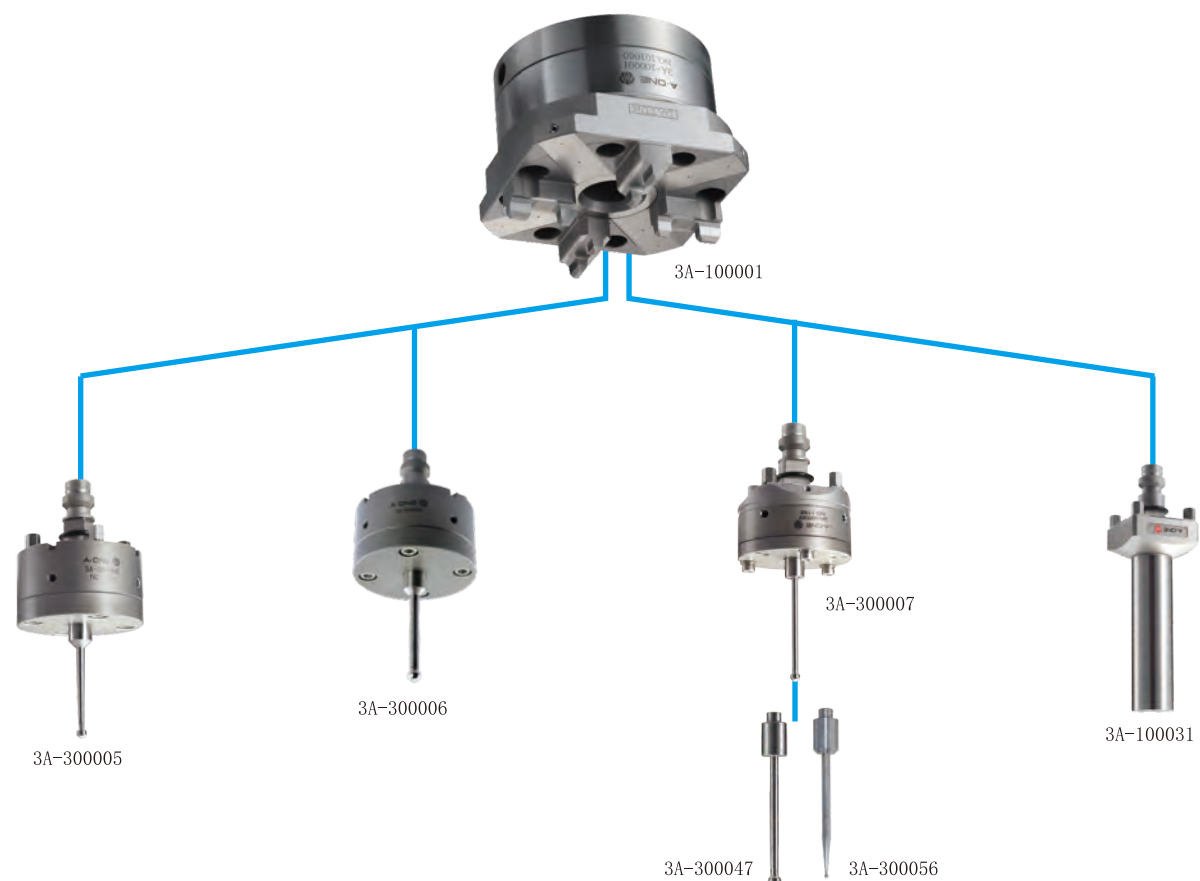

3A-300005 EDM 零位基准 Dφ5
Sensor with ball Dφ5

- ▶ 规格 固定型, 重复定位精度: X, Y, Z 方向0.002mm
- ▶ 应用 在数控电火花成型机床上工件的自动测量
- ▶ Version Fixed type, Repetition accuracy: x, y, z 0.002mm
- ▶ Application Automatic measurement of workpieces in CNC EDM sinking centers

3A-300006 EDM 零位基准 Dφ8
Sensor with ball Dφ8

- ▶ 规格 固定型, 重复定位精度: X, Y, Z 方向0.002mm
- ▶ 应用 在数控电火花成型机床上工件的自动测量
- ▶ Version Fixed type, Repetition accuracy: x, y, z 0.002mm
- ▶ Application Automatic measurement of workpieces in CNC EDM sinking centers

3A-300007 EDM 零位基准
Sensor with ball Dφ6

- ▶ 规格 带有弹簧装卡的探针对称度: 0.002mm 可动式测头, 防破坏性设计. Ø6 活动型
- ▶ 应用 适用于 EDM 电火花成型机, 工件或电极基准零位的找正
- ▶ Version Holder with spring-loaded sensing pin symmetric accuracy: 0.002mm. Trouble free flexible ball design. Ø6 flexible type
- ▶ Application To be used on zero point correction for EDM, workpiece and electrode

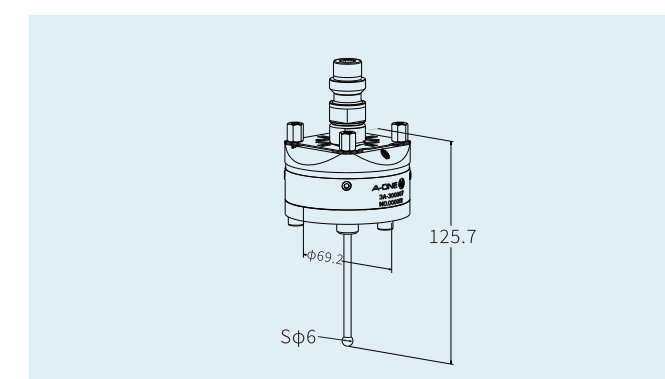
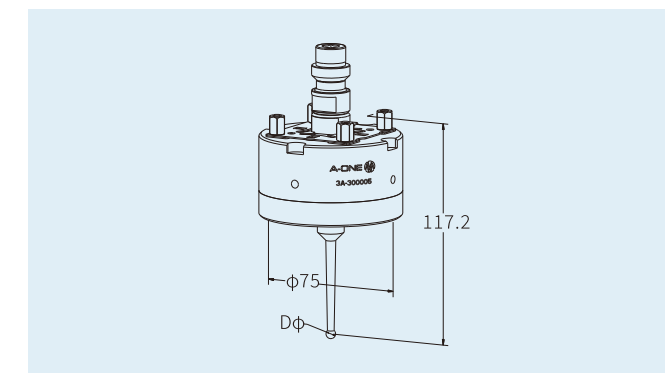

精密测头
Precision replacement sensor pin

产品编号(Model No.)	测头材质(Materia)	测头直径(Diameter)
3A-300109	白钢 (Stainless steel)	φ2
3A-300110	白钢 (Stainless steel)	φ3
3A-300111	白钢 (Stainless steel)	φ4
3A-300112	白钢 (Stainless steel)	φ5
3A-300047	白钢 (Stainless steel)	φ6
3A-300056	钨钢 (Carbide steel)	φ2
3A-300113	钨钢 (Carbide steel)	φ3
3A-300114	钨钢 (Carbide steel)	φ4
3A-300094	钨钢 (Carbide steel)	φ5
3A-300147	钨钢 (Carbide steel)	φ6

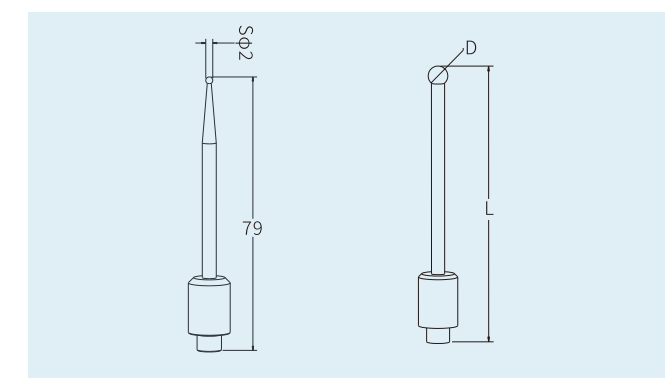

3A-200040 基准杆
Reference pin UnoSet

- ▶ 规格 硬质, 磨削, 孔Ø8mm
- ▶ 应用 水平卡盘上确定测量基准
- ▶ Version Hardened, ground, borehole Ø8mm
- ▶ Application To determine reference measurements on horizontal chucks

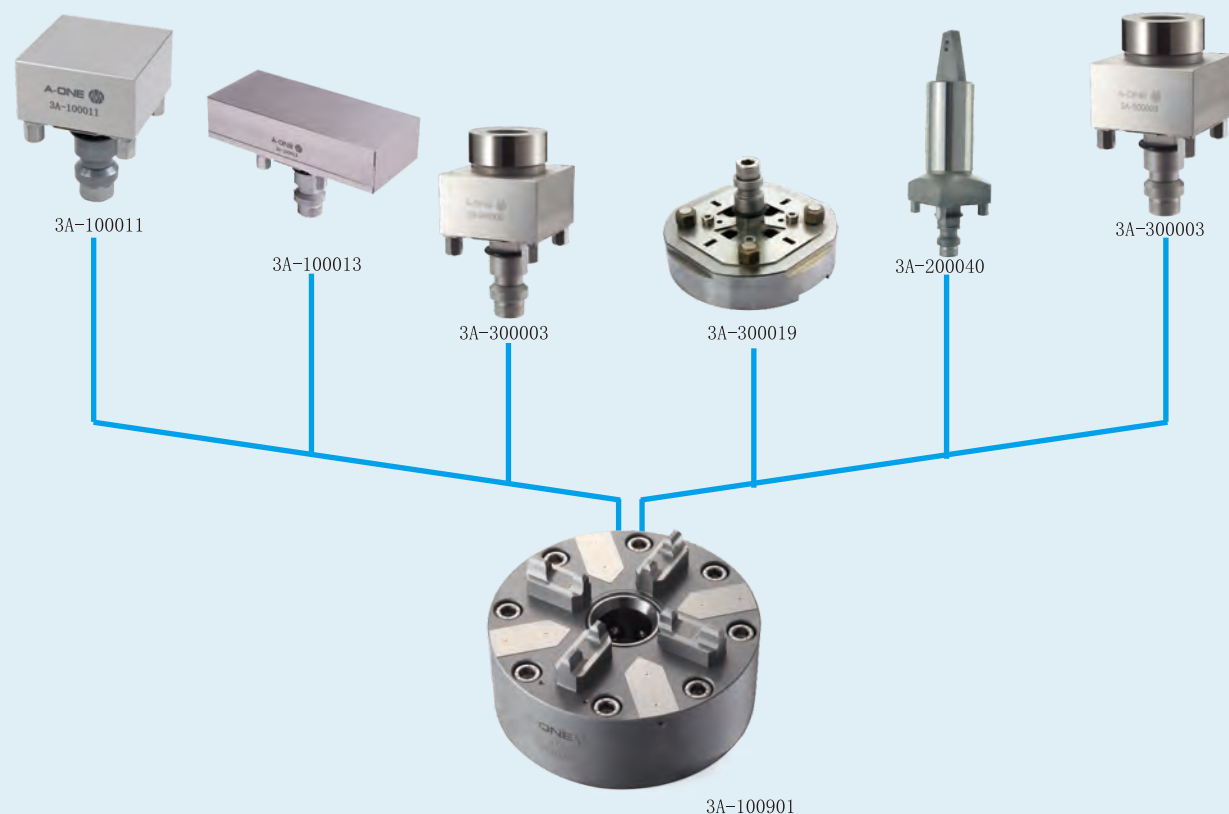
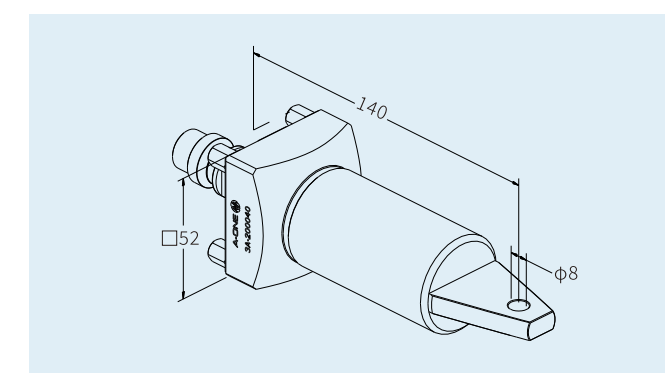

3A-100011 CNC 零位基准
CNC zero point gauge

- ▶ 应用 工件或电极基准位的找正用于CNC加工中心
- ▶ Application To be used on correction of workpiece or electrode datum . For CNC machining center

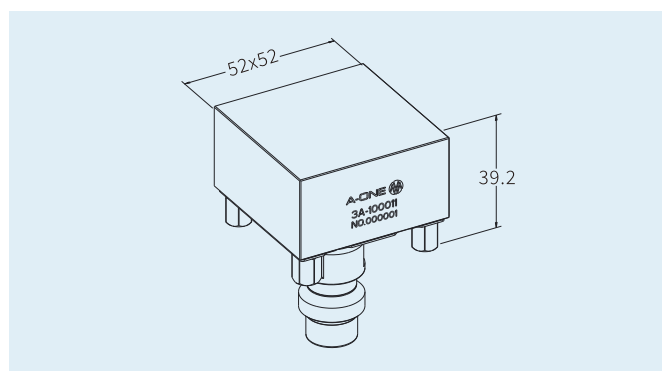

3A-100013 CNC 零位基准
CNC zero point gauge

- ▶ 应用 用于卡盘X、Y、Z方向平行检测，校正
- ▶ Application Used for detection and correction of parallel X,Y and Z directions of the chuck

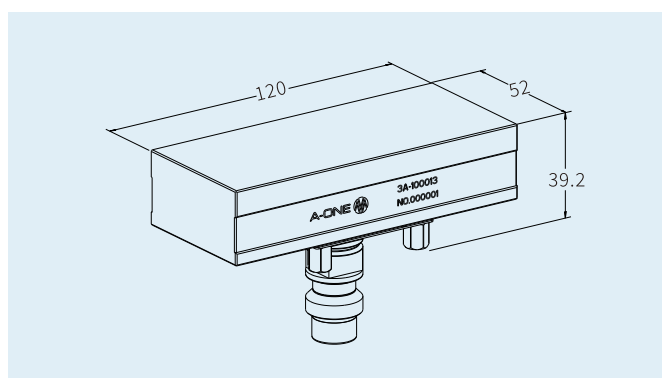

3A-400036 瑞士GIROD 杠杆表
Swiss girod lever meter

- ▶ 规格 测量范围0.2mm，刻度值0.002mm
- ▶ 应用 用于预调设定和预调工作站，及ITS定位装置上
- ▶ Version Measuring range 0.2mm, Graduation 0.002mm
- ▶ Application On Preset setup and pre-setting cells, and on ITS centering devices

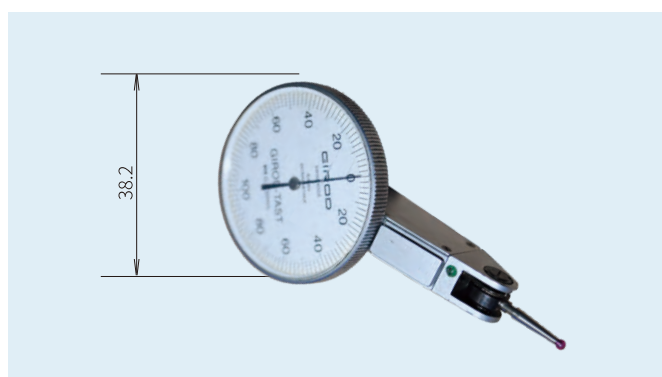

3A-300003 CNC 零位基准
CNC gauging pin

- ▶ 规格 系统尺寸ITS 50，同时拥有圆形和方形两种规格基准
- ▶ 应用 ITS 卡盘零位找正或获得
- ▶ Version ITS system size 50, have both two specification gauge: circle and square
- ▶ Application ITS chucks datum alignment or obtain

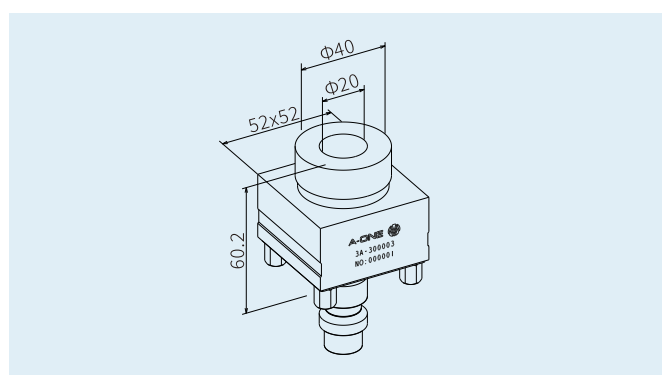

3A-300019 EDM 检测基准
EDM Alignment pallet

- ▶ 规格 系统尺寸ITS 100，Ø120托板，校正长度115mm，中心孔Ø25mm
- ▶ 应用 ITS 卡盘，强力卡盘等卡盘径向、轴向和角度位置的校正
- ▶ Version ITS system size 100, Pallet Ø120mm, alignment length 115mm, center borehole Ø25mm
- ▶ Application Alignment of radial, axial and angular position of ITS chucks, power chuck and so on

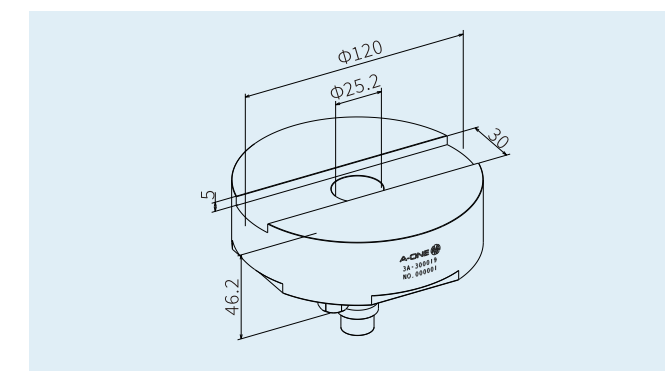

3A-100031 检测杆
Checking pin Ø50

- ▶ 规格 系统尺寸ITS 50，硬质、磨削
- ▶ 应用 ITS 卡盘径向、轴向和角度位置的校正
- ▶ Version ITS system size 50, Hardened, ground
- ▶ Application Alignment of radial, axial and angular position of ITS chucks

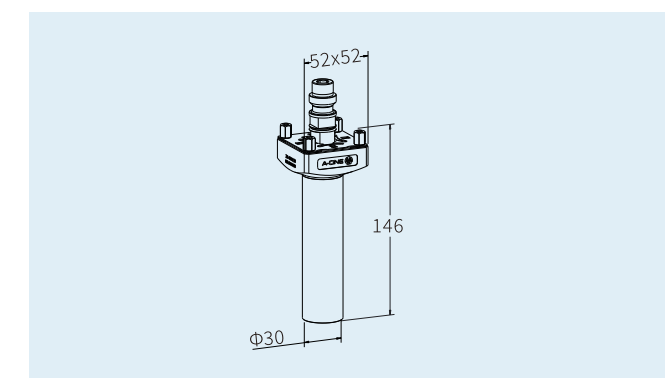

3A-300090 定位球
Locating ball

- ▶ 特点及用途：
1、直接安装到火花机工作台上
2、采用不锈钢材料，配磁性底座
3、球体圆度0.002mm
- ▶ Features and application:
1. Mounted directly on the EDM workbench
2. Made of stainless steel, with a magnetic base
3. Ball roundness 0.002mm

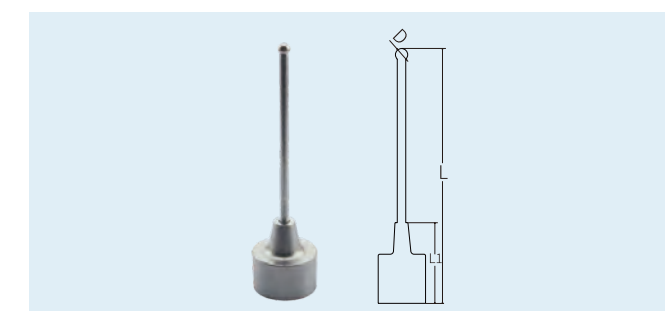

规格 (specifications)	D	L1	L
Ø6×80	Ø6	45	80
Ø8×80	Ø8	45	80
Ø6×150	Ø8	45	150

3A-400009 电极预调台
Electrode presetting station

- ▶ 电极预调台是最理想的设置和预调站，用于快速检测Z轴向平面或在Y轴向校正工件。有了移动推车，您可根据工作情况将其放置在任何需要的地方
- ▶ Electrode presetting station is the ideal setting and presetting station for rapid detection of the Z-axis plane or workpiece calibration in Y-axis. With the mobile cart, you can place it at any place where it is needed according to work conditions
- ▶ 注意事项：通用磁性表座为选购件
- ▶ Note: The universal magnetic base is optional



- ▶ 选择夹持系统，预调站模块化设计，按需要选择夹持系统
- ▶ Select the clamping system, building block design of presetting station, select the clamping system as needed

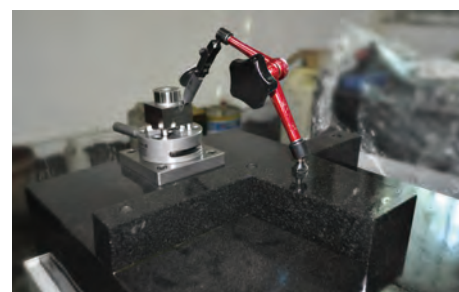

- ▶ 沿着固定的导轨，用活动表座上的千分表校正工件的Z平面或Y轴向校正
- ▶ Along fixed rails, use micrometer gauge on the movable gauge stand calibration Z plane of the workpiece or Y axis calibration

技术参数 Technical parameters

- ▶ 操作时重量：根据实际承载重量订做
- ▶ Weight of operation: customized based on the actual load weight
- ▶ 瑞士GIROD 杠杆表：0.002mm
- ▶ Swiss girod lever meter : 0.002mm
- ▶ 测头系统：模拟式千分表安装于活动表座上
- ▶ Probe system: analog type micrometer gauge mounted on the movable gauge stand

通用磁性表座 Universal magnetic base



3A-400203



3A-400202



3A-400201

3A-400084 双向ITS预调台
Double Sides ITS Presetting Station

- ▶ 平台材质与尺寸 济南青 600x400x130mm
- ▶ 配件 1、上银高精度导轨，行程270x150mm
2、强力万向磁性表座（机械式），臂长350mm
3、瑞士千分表，读值0.002mm，测量范围0.2mm，表径38mm，测头长度12mm
- ▶ 精度 导轨行走精度0.005/100mm，大理石精度等级：00级
- ▶ 注意事项 根据客户需求选配ITS卡盘，可配3A-100902、3A-100050等使用
报价不含卡盘，卡盘需另购
通用磁性表座为选购件
- ▶ Platform material and size cyanogen 600x400x130mm
- ▶ replacement 1、Shang yin silver rail, stroke 270x150mm
2、Powerful universal magnetic table (mechanical) arm length 350mm
3、Swiss dial gauge, Reading value 0.002mm, measuring range 0.2mm, diameter ϕ 38mm, measuring head length 12mm
- ▶ Accuracy The walking precision of the guide rail is 0.005/100mm. Marble accuracy grade: 00 level
- ▶ Precautions Optional ITS chucks according to customer needs, can be used with 3A-100902, 3A-100050, etc. Chuck supplied separately. The universal magnetic base is optional

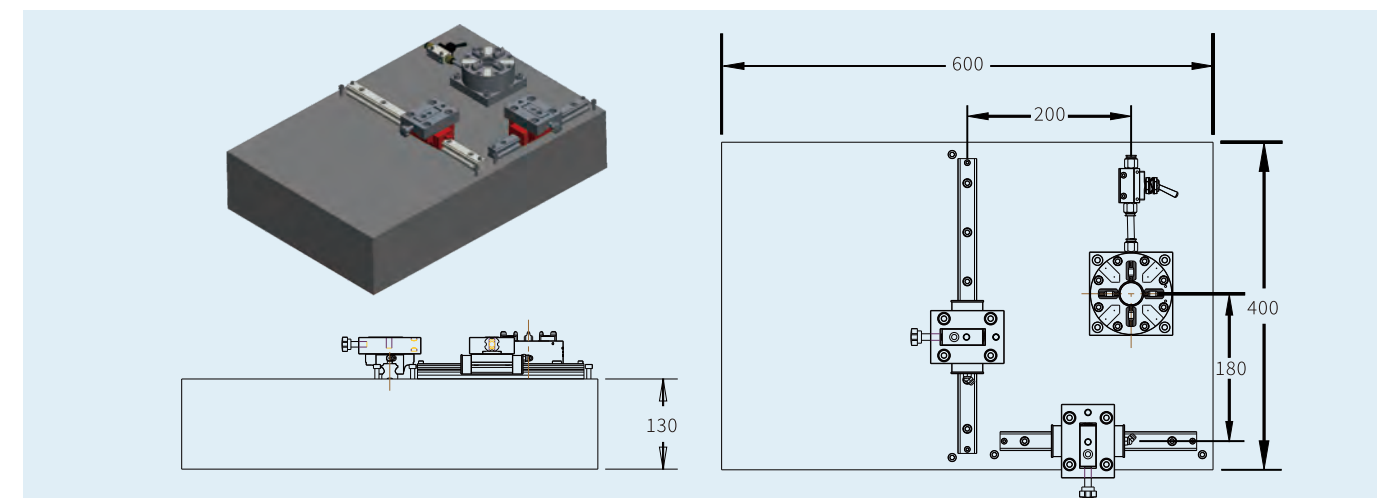

花岗石检测平板 Granite inspection surface plate

花岗石平板精度参考各先进国家标准，平面度公差依GB/T20428-2006岩石平板标准：
Granite surface plate refers to the advanced standards of the developed countries, and its flatness tolerance is in accordance with the GB/T 2048-2006 Surface plate Standards:

000级	(0.003x +2.5) 4 μ m
00级	(0.003x +2.5) 2 μ m
0级	(0.003x +2.5) μ m
1级	(0.006x +5) μ m
Grade 000	(0.003x +2.5) 4 μ m
Grade 00	(0.003x +2.5) 2 μ m
Grade 0	(0.003x +2.5) μ m
Grade 1	(0.006x +5) μ m

承接非标花岗石预调台定制

通用磁性表座 Electrode presetting station



3A-400203



3A-400202



3A-400201

<http://www.szjztools.com>
<http://www.system3a.com>

最新产品信息、公司资讯等敬请浏览本公司主页
Please visit our homepage for the latest product information, company information, etc.

R型系列夹具

R Series fixture

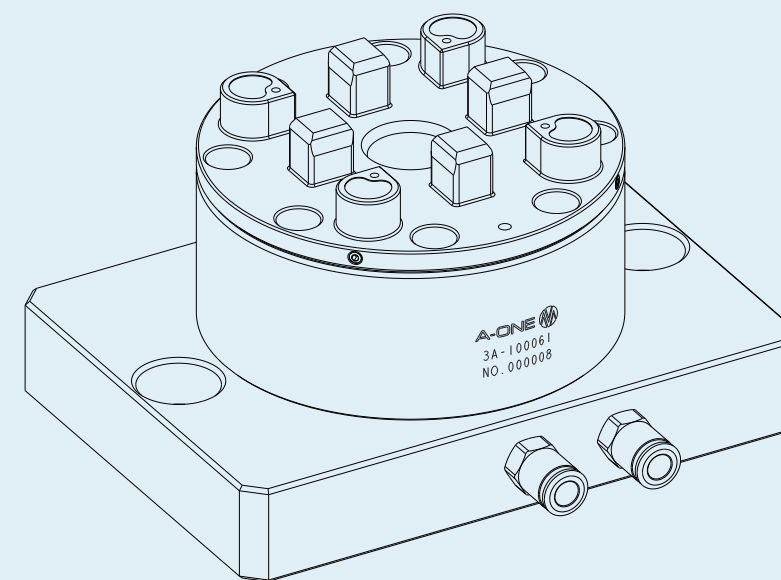

基准卡盘及CNC夹具
Benchmark chuck and
CNC jig

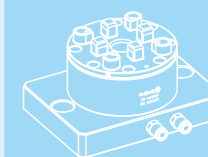

P.067~P.075

夹紧拉钉及定位片
Chuck spigots and
Centering plates



P.076~P.077

标准电极夹具座
Standard electrode holder

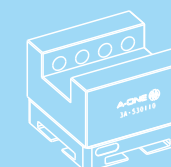

P.078~P.087

电极附件及检测杆
Electrode combi and
Checking pin

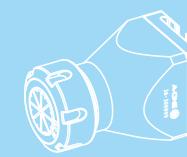

P.088~P.089

System 3A

基准卡盘及CNC 夹具 Benchmark chuck and CNC jig

专业 可靠 耐用 精密
professional reliable durable precision

气动、手动、工作台用 Pneumatic or Manual Used on work table



3A-100061 R型气动卡盘 R type automatic chuck

- ▶ 规格 配拉钉3A-400043
解锁气压 0.6MPa,
固定分度位置4*90 度
气喷清理Z—M 基准面
- ▶ 夹紧力 6000N
- ▶ Version Used with spigot 3A-400043
Unlocking air pressure is 0.6MPa
Division value:4*90
Air cleaning Z—M Datum side
- ▶ Clamping Power 6000N

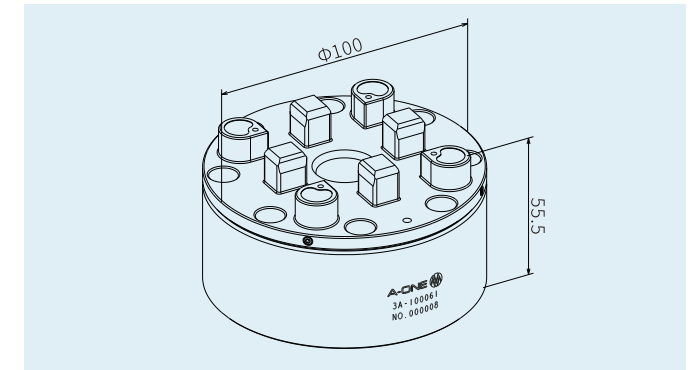

3A-100062 R型工作台卡盘 R Chuck with plate

- ▶ 规格 解锁气压 0.6MPa
固定分度位置4*90 度
气喷清理Z—M 基准面
侧面进气、防腐蚀
- ▶ 夹紧力 6000N
- ▶ Version Unlocking air pressure is 0.6MPa.
Division value:4*90
Air cleaning Z—M Datum side
Air connection on the side
Resistant corrosion
- ▶ Clamping Power 6000N

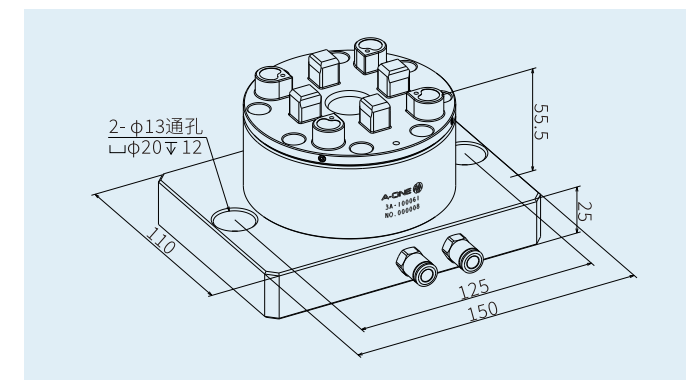

3A-100070 轻型气动R卡盘 R type light Pneumatic chuck

- ▶ 规格 重1.2KG, 夹紧力2400N
- ▶ 应用 小型EDM主轴
- ▶ 安装 8-M6从正面, 所需拉杆为3A-400043
- ▶ Version NW 1.2kg, clamping force 2400N
- ▶ Application Small EDM spindle
- ▶ Mounting 8-M6 from front side, required drawbar is 3A-400043



R 型系列夹具

R Series fixture

提供 3R 电极生产和 EDM 电火花机床基准系统的整体解决方案, 重复定位精度可达 0.002mm

Offer 3R electrode production and EDM reference system entire solution

Repetition accuracy of 0.002 mm

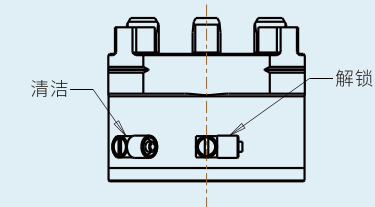
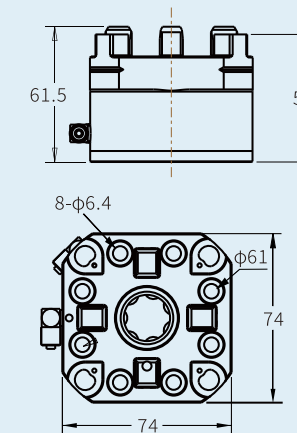

3A-100903 R 型手动卡盘
R manual chuck

- ▶ 规格 不锈钢, 淬硬
- ▶ 夹紧力 8000N
- ▶ 应用 适用于加工中心、火花机、三坐标测量仪、磨床等加工和检测设备, 安装在工作台面或机床主轴上, 也可用于自动生产线
- ▶ Version Stainless steel, hardened
- ▶ Clamping Power 8000N
- ▶ Application To be used on cnc machining center, edm, coordinates measuring machine, grinding lathe etc processing and inspection equipment, mounted on work table or machine tool spindle, also can be used on automatic production line

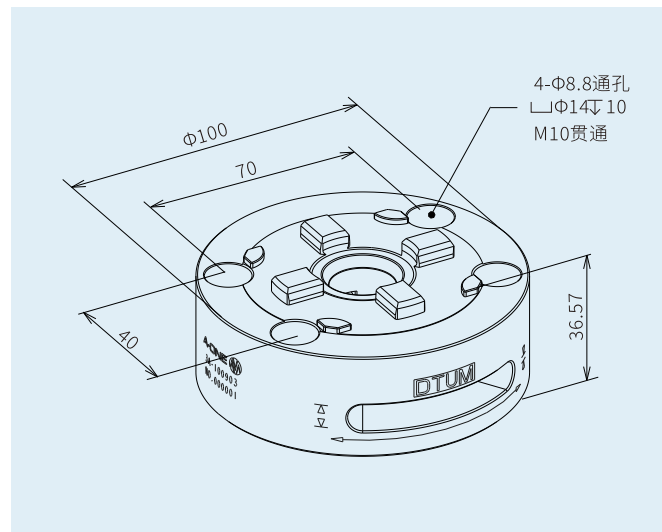

3A-100063 R 型直角卡盘
R Vertical chuck

- ▶ 规格 气动锁紧功能, 可侧向四面加工, 含卡盘
- ▶ 夹紧力 6000N
- ▶ 安装 直接安装在工作台上
- ▶ 应用 用于CNC 加工中心、磨床、铣床进行安装
- ▶ Version Power pneumatic lock, four sides of workpiece can be machined, with chuck
- ▶ Clamping Power 6000N
- ▶ Mounting To be mounted directly on the table of machining center
- ▶ Version Using in CNC, grinding machine, milling machine

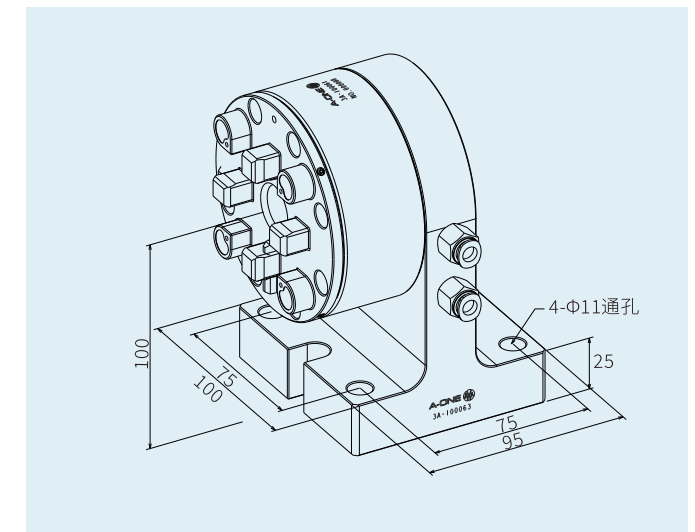

3A-100908 R 型手动卡盘 (带底板)
R manual chuck (with plate)

- ▶ 规格 不锈钢, 淬硬
- ▶ 夹紧力 8000N
- ▶ 应用 适用于加工中心、火花机、三坐标测量仪、磨床等加工和检测设备, 安装在工作台面或机床主轴上, 也可用于自动生产线
- ▶ Version Stainless steel, hardened
- ▶ Clamping Power 8000N
- ▶ Application To be used on cnc machining center, edm, coordinates measuring machine, grinding lathe etc processing and inspection equipment, mounted on work table or machine tool spindle, also can be used on automatic production line

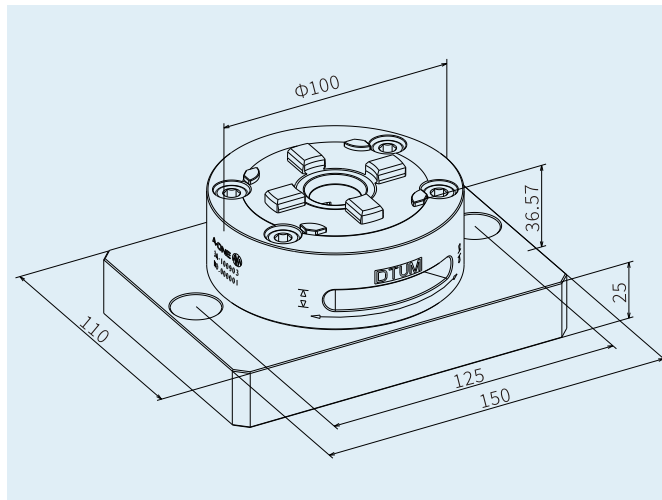

3A-100076 R 150气动卡盘
R 150 pneumatic chuck

- ▶ 规格 解锁气压 0.6MPa、固定分度位置 4*90 度
气喷清理Z-基准面
- ▶ 夹紧力 15000N
- ▶ 安装 带底板, 4-12螺丝安装过孔、适配3A-400043拉钉
安装于机床工作台上
- ▶ 净重 12.39kg
- ▶ Version Unlocking air pressure is 0.6 MPa, Division value 4*90°, Air cleaning Z-M Datum side
- ▶ Clamping Power 15000N
- ▶ Mounting With base plate, 4-12screw mounting holes, used with drawbar 3A-400043, mounted on machine table
- ▶ Net weight 12.39kg

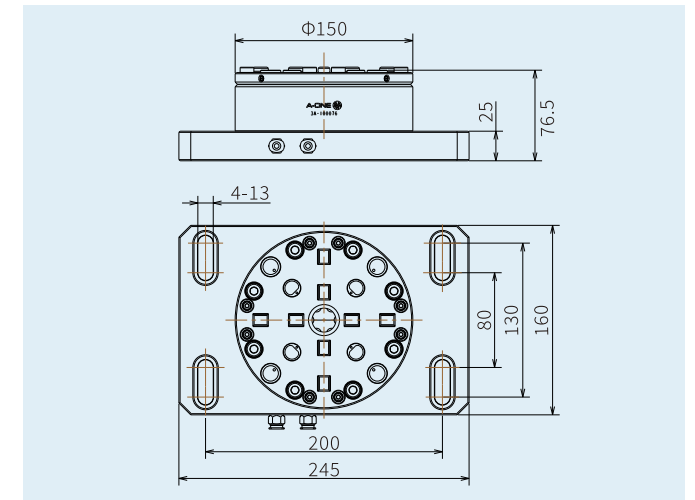

3A-100073 R50手动卡盘
R50 Manual chuck

- ▶ 规格 R50手动
- ▶ 夹紧力 4000N
- ▶ 安装 4-M8从背面或4-M6从正面
- ▶ 应用 适用定位片3A-400008; 适用拉杆3A-400006
- ▶ Version R50 manual
- ▶ Clamping Power 4000N
- ▶ Mounting 4-M8 from the back side or 4-M6 from the front side
- ▶ Application Suitable for Centering plate 3A-400008 ; Suitable for drawbar 3A-400006

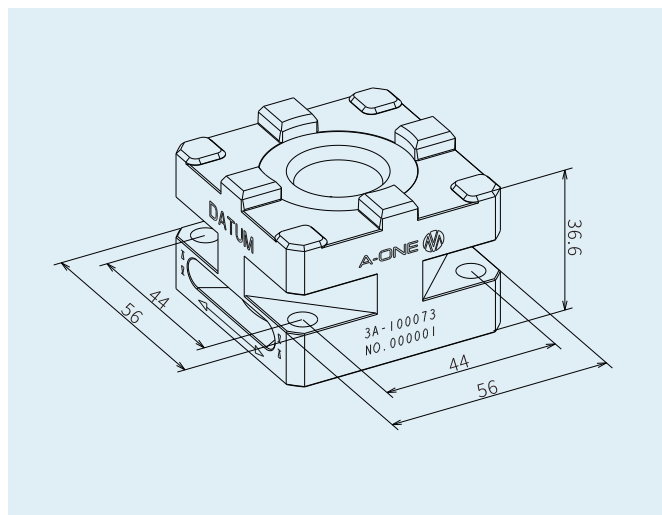

3A-110088 R型托盘φ156
R type Plate φ156

- ▶ 规格 钢, 耐腐蚀
- ▶ 应用 适用于自动更换
- ▶ 安装 带螺纹和通孔, 可安装8或10个固定螺丝
- ▶ 净重 5kg
- ▶ Version Steel, corrosion-resistant
- ▶ Application Adapted for automatic changing
- ▶ Mounting With threads and clearance holes for eight and ten fixing screws
- ▶ Net weight 5kg

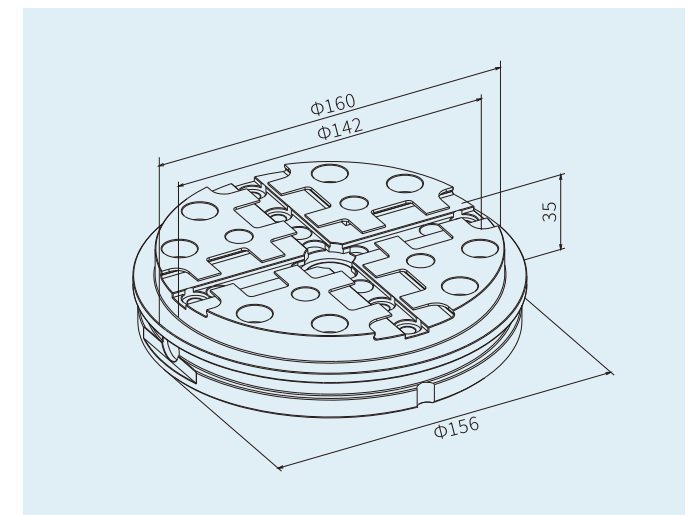

3A-400141 R 强力定位片
R power centering plate

- ▶ 规格 硬质基准片, 防锈
- ▶ 应用 先固定于工件或夹具的底部, 然后锁定在卡盘中
- ▶ 重量 1kg
- ▶ Version Hardened, rust-resistant
- ▶ Application Must be mounted on the workpiece/fixture before it is locked in a chuck
- ▶ Net weight 1kg

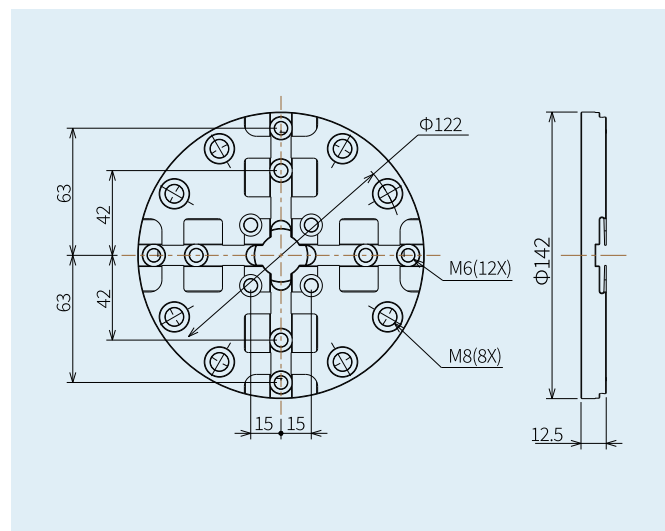

3A-100064 R型两中心100气动卡盘
R Auto chuck - double

- ▶ 规格 不锈钢, 淬硬, 气动控制0.6Mpa, 带清洁功能, 预制底板, 标准产品卡盘中心距140mm, 可根据客户要求订做, 价格另议
- ▶ 夹紧力 6000N
- ▶ 安装 直接安装在机床工作台上
- ▶ 应用 安装孔请参考安装说明书加工
- ▶ Version Stainless steel, hardened, pneumatic power 0.6Mpa, cleaning function, Base plate can be made in accordance Standard center to center distance 140mm, OEM Service available, the price is negotiable
- ▶ Clamping Power 6000N
- ▶ Mounting To be directly mounted on the table of machining center
- ▶ Application Please refer to the installation instructions for processing mounting holes

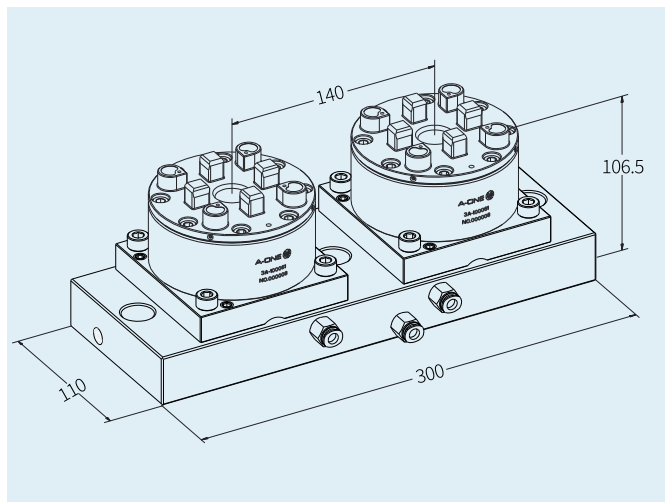

3A-100065 R 型四中心100 气动卡盘
R Auto chuck - quato

- ▶ 规格 不锈钢, 淬硬, 气动控制0.6Mpa, 带清洁功能, 预制底板, 标准产品卡盘中心距140*120mm, 可根据客户要求订做, 价格另议
- ▶ 夹紧力 6000N
- ▶ 安装 直接安装在机床工作台上
- ▶ 应用 安装孔请参考安装说明书加工
- ▶ Version Stainless steel, hardened, pneumatic power 0.6Mpa, cleaning function, Base plate can be made in accordance Standard center to center distance 140*120mm, OEM Service available, the price is negotiable
- ▶ Clamping Power 6000N
- ▶ Mounting To be directly mounted on the table of machining center
- ▶ Application Please refer to the installation instructions for processing mounting holes

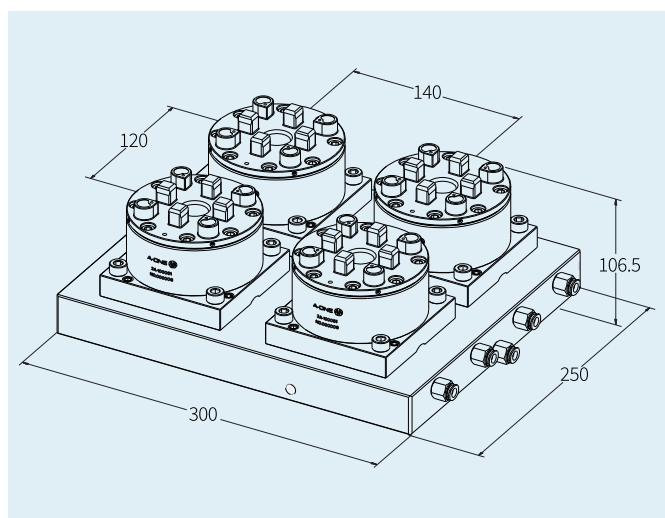

3A-100066 单列三位R 型卡盘
Three-fold R chuck

- ▶ 规格 不锈钢, 淬硬, 气动控制0.6Mpa, 带清洁功能, 预制底板, 标准产品卡盘中心距120mm, 可根据客户要求订做, 价格另议
- ▶ 夹紧力 6000N
- ▶ 安装 直接安装在机床工作台上
- ▶ 应用 安装孔请参考安装说明书加工
- ▶ Version Stainless steel, hardened, pneumatic power 0.6Mpa, cleaning function, Base plate can be made in accordance Standard center to center distance 120mm, OEM Service available, the price is negotiable
- ▶ Clamping Power 6000N
- ▶ Mounting To be directly mounted on the table of machining center
- ▶ Application Please refer to the installation instructions for processing mounting holes

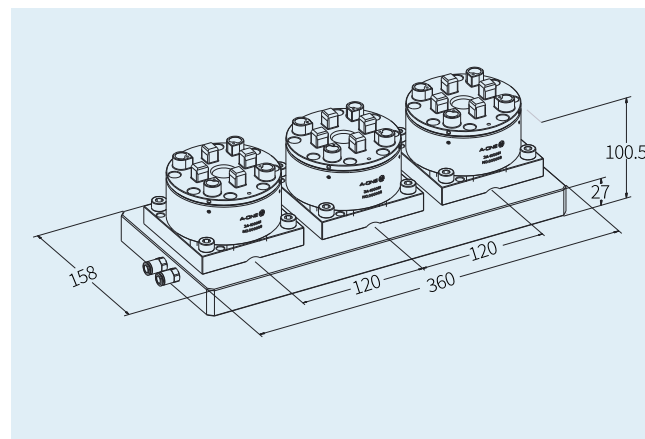

单列三位R 型卡盘组合示意图
Three-fold R chuck combination drawings

- ▶ 规格 排列组合参考图, 可按客户工作台大小组合
三中心组合 2x3、3x3、4x3
标准产品卡盘中心距: 160*120mm
可根据客户要求订做, 价格另议
- ▶ Version Reference drawings, Combination can be customized according to customer's machine table
3-fold 2*3、3*3、4*3
Standard center to center distance 160*120mm
OEM Service available, the price is negotiable

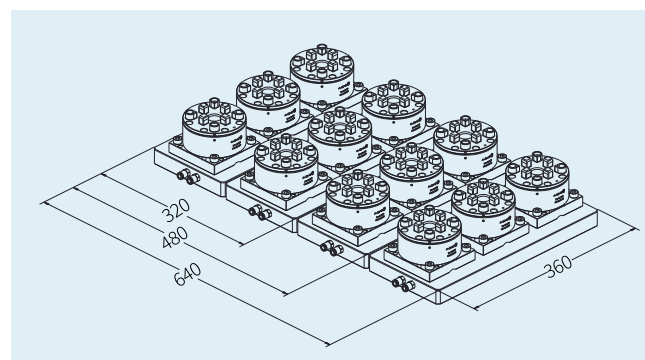

3A-100067 单列四位R 型卡盘
Four-fold R chuck

- ▶ 规格 不锈钢, 淬硬, 气动控制0.6Mpa, 带清洁功能, 预制底板, 标准产品卡盘中心距120mm, 可根据客户要求订做, 价格另议
- ▶ 夹紧力 6000N
- ▶ 安装 直接安装在机床工作台上
- ▶ 应用 安装孔请参考安装说明书加工
- ▶ Version Stainless steel, hardened, pneumatic power 0.6Mpa, cleaning function, Base plate can be made in accordance Standard center to center distance 120mm, OEM Service available, the price is negotiable
- ▶ Clamping Power 6000N
- ▶ Mounting To be directly mounted on the table of machining center
- ▶ Application Please refer to the installation instructions for processing mounting holes

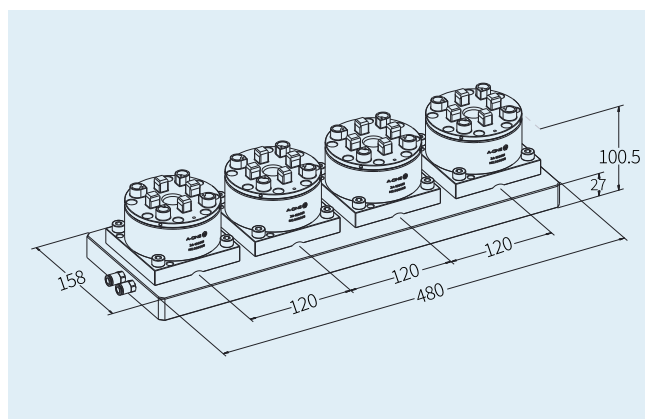

单列四位R 型卡盘组合示意图
Three-fold R chuck combination drawings

- ▶ 规格 排列组合参考图, 可按客户工作台大小组合
四中心组合 2x4、3x4、4x4
卡盘中心距 160*120 mm
- ▶ Version Reference drawings, Combination can be customized according to customer's machine table
4-fold 2*4、3*4、4*4
Center to center distance 160*120 mm

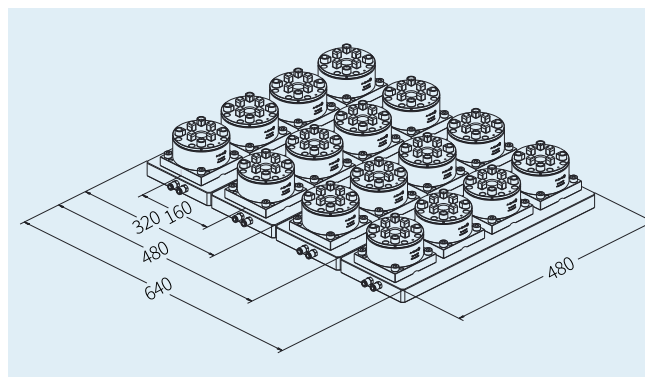

3A-110099 ER40筒夹套
ER 40 collet

- ▶ 应用 适用圆形工件夹持，可通过最大 $\phi 32\text{mm}$ 的挂台
- ▶ 注意 托板需另购
- ▶ Application Suitable for circular workpieces clamping, Can pass the maximum $\phi 32\text{mm}$ hanging platform
- ▶ Note Pallet kit supplied separately

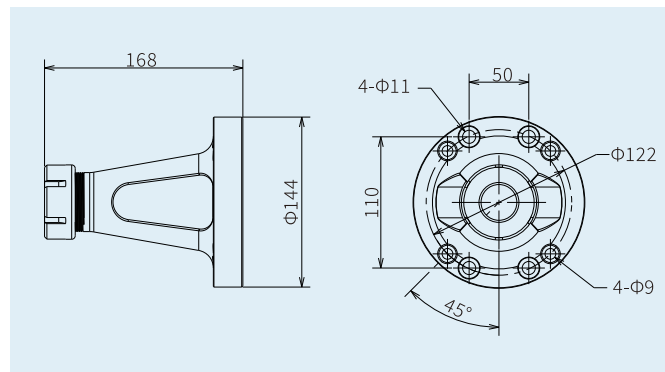

应用案例
Application case



ER40筒夹套配ITS托板，实现快速装夹
Er40 collet sleeve is equipped with ITS pallet to realize rapid clamping

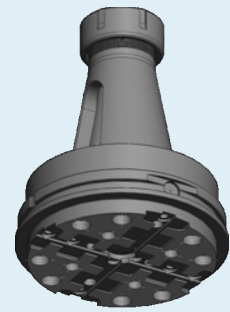

ER40筒夹套配R型托板，实现快速装夹
Er40 collet sleeve is equipped with Rtype pallet to realize rapid clamping

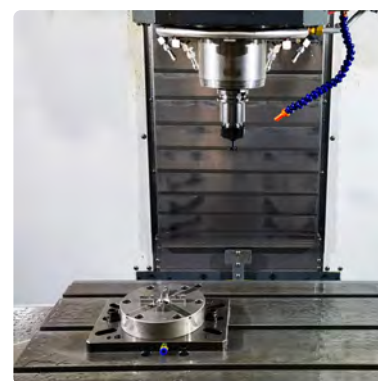

托盘在卡盘上快速装夹定位
Quick clamping and positioning of pallet on chuck



侧面开口处打表校正零件基准边
Calibrate the reference edge of the part at the side opening

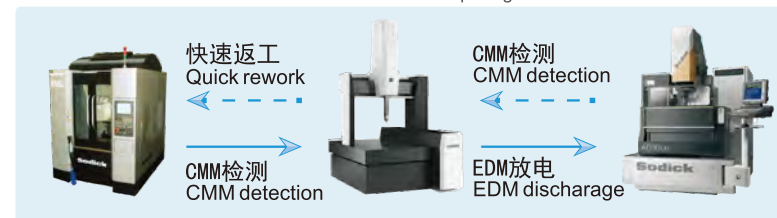

筒夹定心、侧面打表校正基准边，实现零件快速定位装夹。零件定位好后，可随托盘快速进行工序衔接
Centering the collet, calibrate the reference edge on the side, to realize rapid positioning and clamping of the parts. The parts can be quickly connects process with the pallet after positioned.

3A-300095 R 型主轴气动卡盘
R EDM chuck

- ▶ 规格 按客户机床定制，卡盘需另购
如需订货，请参考示意图提供以下数据：
与机头对应的安装孔的大小($\phi Z/MZ$)和相对位置(X, Y)是否需要绝缘板组件P1、P2、P3。
- ▶ 应用 适用于电火花成型机，直接安装在机头上
- ▶ Version Customized as per machine. chuck supplied separately
Please after drawings and data
Pease advice relative of holes ($\phi Z / MZ$) on EDM head and their X, Y positions
Whether insulating plates are needed or not, P1, P2, P3
- ▶ Application To be directly mounted on EDM head

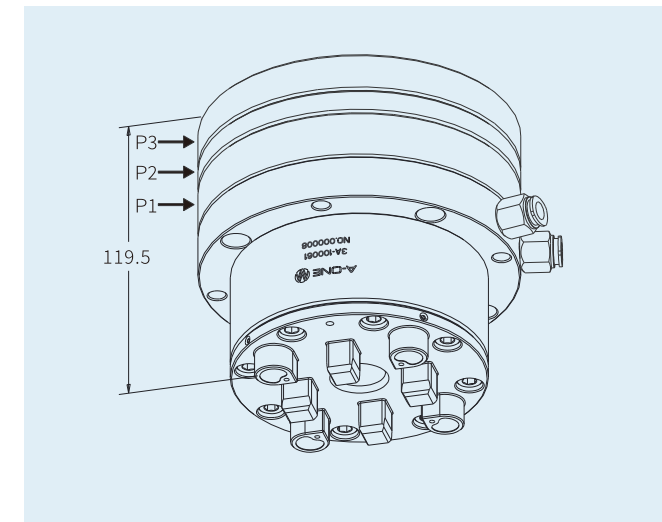

3A-300105 R50延长卡盘 (6吋)
R50 Extension chuck (6 inch)

- ▶ 规格 延长长度6英寸，配R50手动卡盘
- ▶ 应用 放电机主轴
- ▶ Version Extended length 6 inches, with R50 manual chuck
- ▶ Application Motor shaft

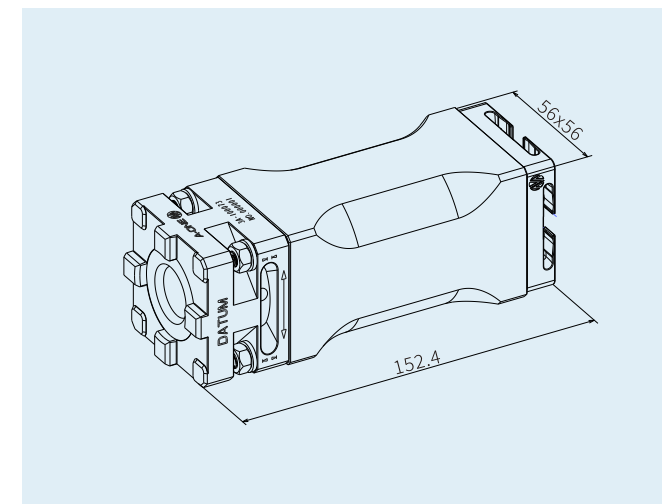

3A-300106 R50延长卡盘 (10吋)
R50 Extension chuck (10inch)

- ▶ 规格 延长长度10英寸，含R50手动卡盘
- ▶ 应用 放电机主轴
- ▶ Version Extended length 10 inches, with R50 manual chuck
- ▶ Application Motor shaft

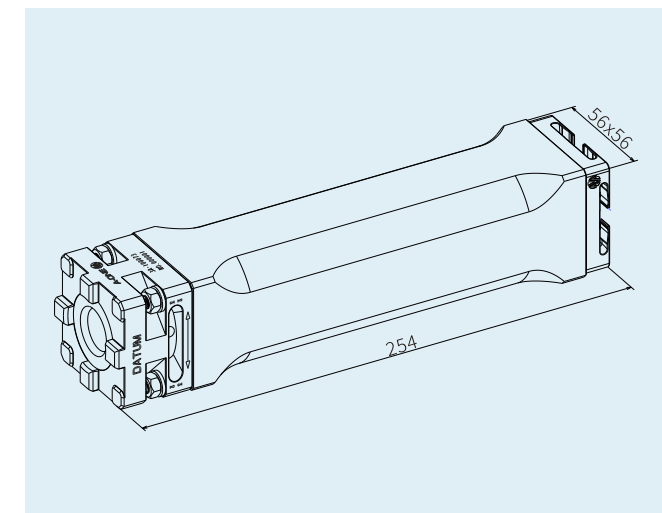

3A-200127 R型延伸臂
R Extension arm UnoSet

- ▶ 规格 可由垂直加工转为水平式加工
加工方便、快捷
含卡盘
- ▶ 应用 适用于各种线割机, 电火花
- ▶ 净重 2.3KG
- ▶ Version Can be changed from vertical position to horizontal position
Easy and quick change
With chuck
- ▶ Application To be used on all types of wire-cut EDM or EDM
- ▶ Net weight 2.3KG

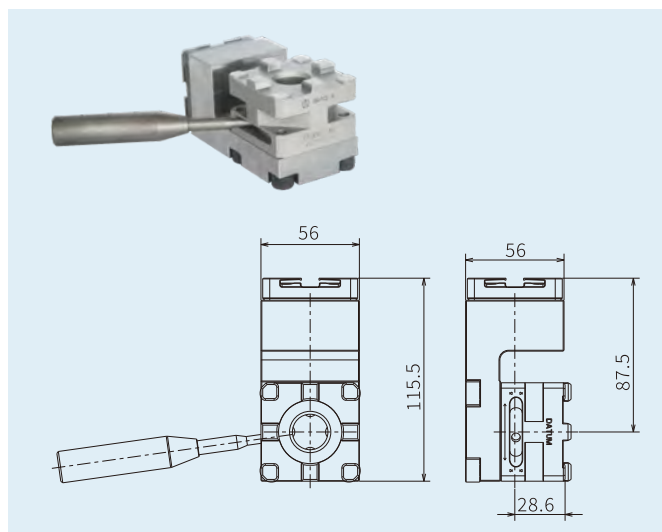

3A-300049 转接头
Replaceable head

- ▶ 规格 System 3R 转EROWA 50
- ▶ 应用 中心及角度精度0.005, 适用于EDM
- ▶ Version System 3R change to EROWA system 50
- ▶ Application Center and angel precision 0.005mm
Suited for EDM machine

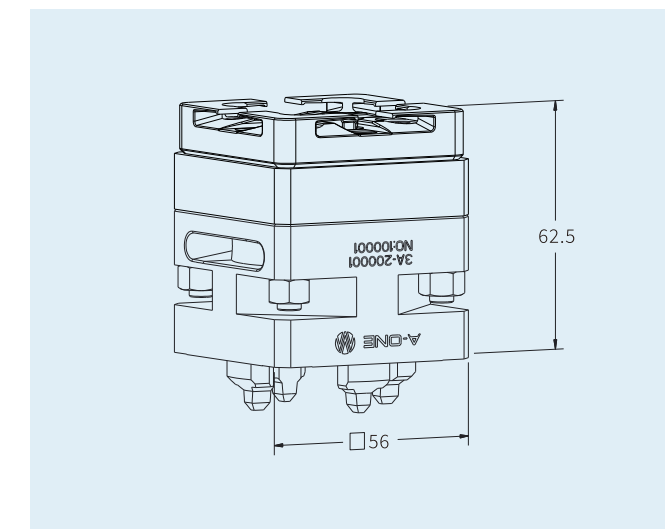

3A-300150 R型角度旋转卡盘
R type angle rotary chuck

- ▶ 规格 延长长度10英寸, 含R50手动卡盘
- ▶ 应用 放电机主轴
- ▶ Version Extended leneh 10 inches , with R50 manual chuck
- ▶ Application Motor shaft

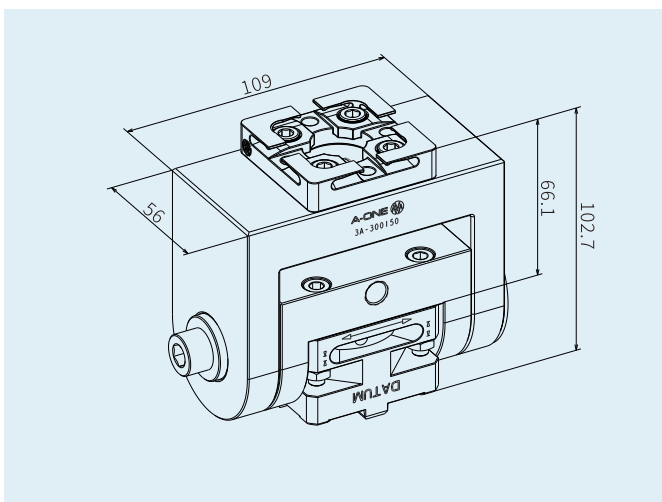

3A-300055 转接头 (EROWA 转3R)
Replaceable head

- ▶ 规格 EROWA 转 SYSTEM 3R
- ▶ 应用 适用于EDM 或CNC
- ▶ Version EROWA change to system 3R
- ▶ Application Suited for EDM or CNC machine

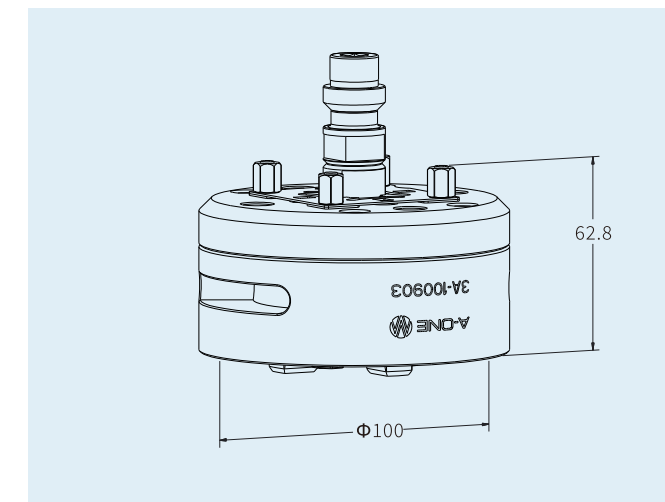

3A-300118 角度旋转夹头R
Angle rotating chuck R

- ▶ 分度 0 - 90°, 每齿5°
- ▶ 规格 3R接口, ER16筒夹(φ1.0-φ10)
- ▶ 应用 EDM机床, 电极摆角度放电
- ▶ 注意 不可用于铣削, 标准产品不含ER筒夹
- ▶ Graduation 0-90°, 5° per tooth
- ▶ Version 3R interface, ER16 collet (φ1.0-10mm)
- ▶ Application EDM machine. The electrode discharges at an angle.
- ▶ Note Not for milling, the standard product does not contain ER collets.

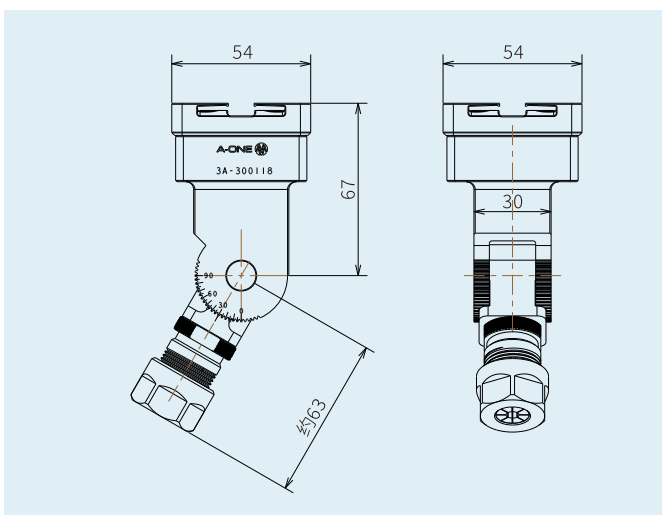

3A-300059 转接头
Replaceable head

- ▶ 规格 System 3R转 EROWA , 中心及角度误差小于0.005mm
- ▶ 应用 适用于EDM或CNC
- ▶ Version System 3R change to EROWA,Center and angle tolerance ≤ 0.005mm
- ▶ Application Suited for EDM or CNC machine

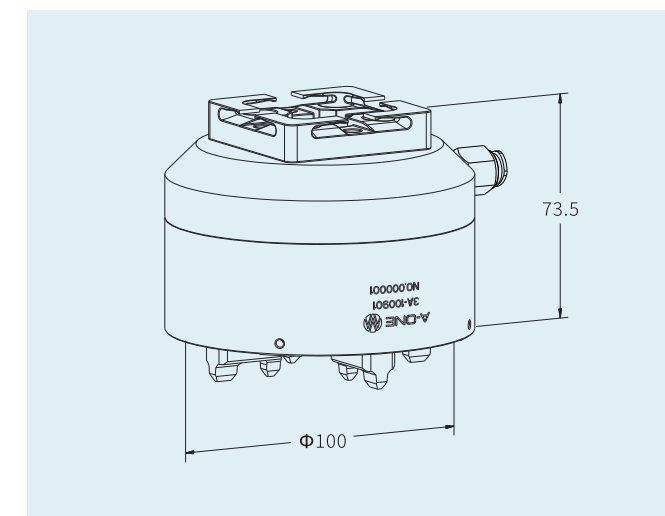

3A-400008 R型定位片
R Centering plate

- ▶ 规格 用于铜电极和工件 54*54mm 淬火基准元件
必须先安装在铜坯件/工件上
- ▶ 注意 对于石墨电极, 需使用垫板
必须先被安装在工件或夹具上再夹入卡盘
- ▶ Version Reference Element 54X54
Side faces for copper electrodes and workpieces
Must used palte if you clamp graphite
- ▶ Note Must be mounted on a workpiece/fixture before being clamped in the chuck

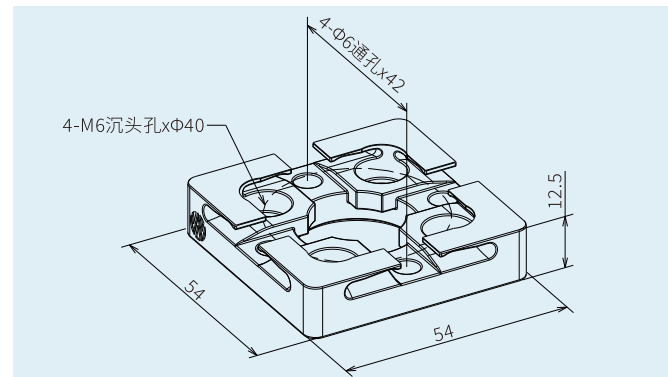

3A-400090 R型定位片 70X70
R Centering Plate 70*70

- ▶ 规格 用于铜电极和工件, 70x70mm, 淬火基准元件
必须先安装在铜坯件/工件上
- ▶ 注意 对于石墨电极, 需使用垫板
必须被安装在工件/夹具的卡盘被夹持前
- ▶ Version Reference Element 70x70mm
Side faces for copper electrodes and workpieces
Must used palte if you clamp graphite
- ▶ Note Must be mounted on a workpiece/fixture before being clamped in the chuck

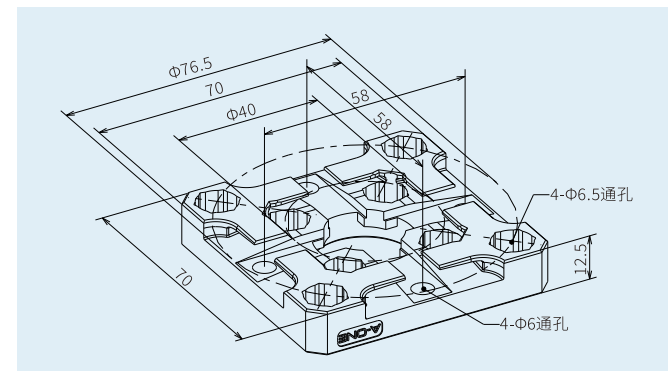

3A-400006 R型拉钉
R Type drawbar

- ▶ 规格 Φ20 x36.9 mm, 带有Φ7mm冲洗孔
防锈
单独供应
- ▶ 应用 可兼容R型产品, 配合手动卡盘使用
- ▶ Version Ø20*36.9 mm with flushing holes Ø7 mm
Rust-resistant
Supply separately
- ▶ Application Compatible with R product, used with manual chuck

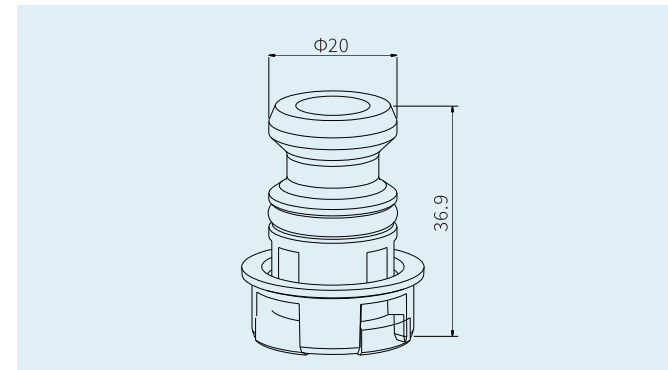

3A-400043 R型拉钉
R Type drawbar

- ▶ 规格 Ø20 x 57mm 带有Ø7 mm冲洗孔
防锈
单独供应
- ▶ 应用 可兼容R型产品, 配合气动卡盘使用
- ▶ Version Ø20*57 mm with flushing holes Ø7 mm
Rust-resistant
Supply separately
- ▶ Application Compatible with R product, used with pneumatic chuck

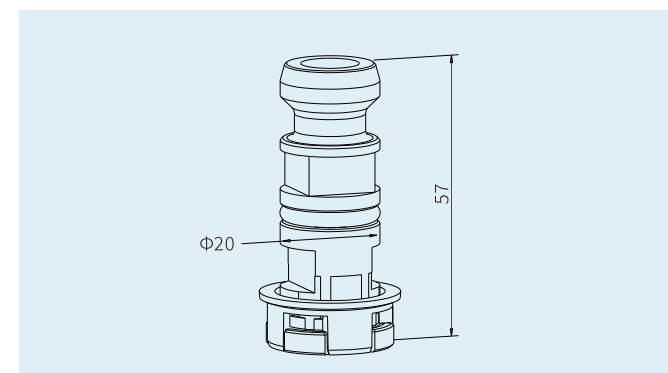

3A-100077 压机气动卡盘R30
Press pneumatic chuck R30

- ▶ 规格 解锁气压 0.6MPa, 固定分度位置 4*90°
气喷清理Z-基准面
- ▶ 夹紧力 6600N (增压气压0.6MPa)、1000N (增压气压1MPa)
- ▶ 重复定位精度 0.002mm
- ▶ 额定压力负荷 32吨
- ▶ 应用 用于粉末压铸机器
- ▶ Version Unlocking air pressure 0.6MPa, division value 4*90°,
Air blast cleaning Z-datum plane
- ▶ Clamping force 6600N (boost pressure 0.6Mpa),
1000N(boost pressure 1Mpa)
- ▶ Repetition accuracy 0.002mm
- ▶ Rated pressure 32 ton load
- ▶ Application For powder die casting machines

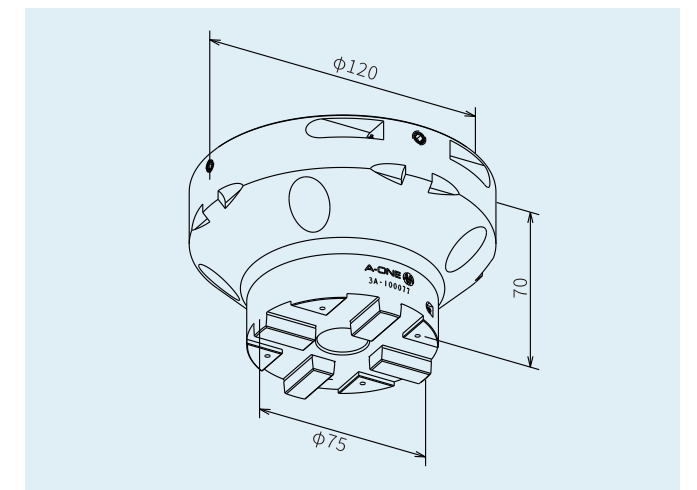

3A-400108 R54定位片
R 54 Centering Plate

- ▶ 规格 54x54mm, 淬火基准元件, 重复定位精度小于0.001mm
- ▶ 规格 不锈钢 (防腐蚀)
- ▶ 注意 装夹到卡盘之前必须被安装在工件/夹具底面
- ▶ Version 54x54mm, Quench reference element, repeating accuracy less than 0.001mm
- ▶ Material Stainless steel (anti-corrosion)
- ▶ Note Must be mounted on the workpiece/fixture before being clamped in the chuck

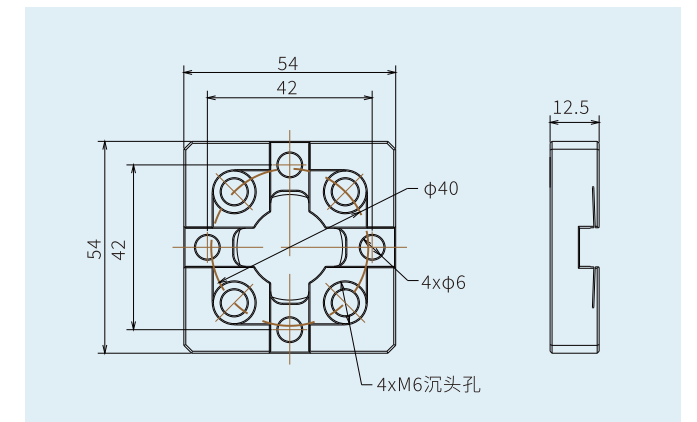

一款专门用于粉末冶金压力机上下模对中的定位元件

A Positioning element specially used for the centering of upper and lower molds of powder metallurgy press



- **简单:基准的统一性和唯一性**
Simplicity: the unity and uniqueness of the benchmark
- **快速:机外预设, 一分钟内定位夹紧**
Fast: preset outside the machine, positioning and clamping within one minute
- **精准:重复定位精度小于0.001mm**
Accuracy: Repeat positioning accuracy is less than 0.001mm



3A-530100 钢电极夹具座
Steel holder

- ▶ 规格 一套12个, 主体未加工
- ▶ 应用 安装各种形状的电极和工件
- ▶ 备注 定位片需另购
- ▶ Version Set of 12 units, fitted without machining of body
- ▶ Application To mount electrodes and workpieces of various shapes
- ▶ Note Centering plates order separately

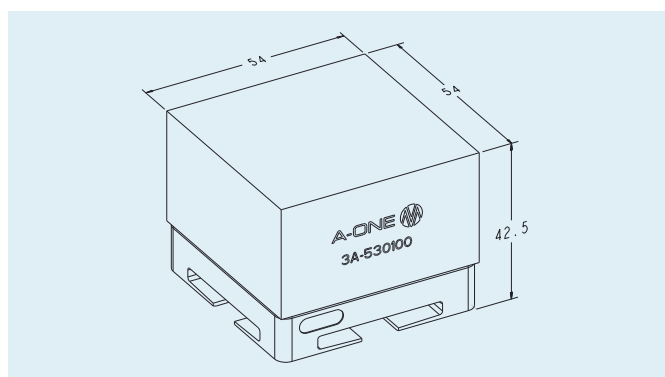

3A-530104 钢电极夹具座
Steel holder

- ▶ 规格 一套12个
- ▶ 应用 用于夹持最大25mm正方形电极或工件
- ▶ 备注 定位片需另购
- ▶ Version Sset of 12 units
- ▶ Application For holding the largest 25mm square electrode or workpiece
- ▶ Note Centering plates order separately

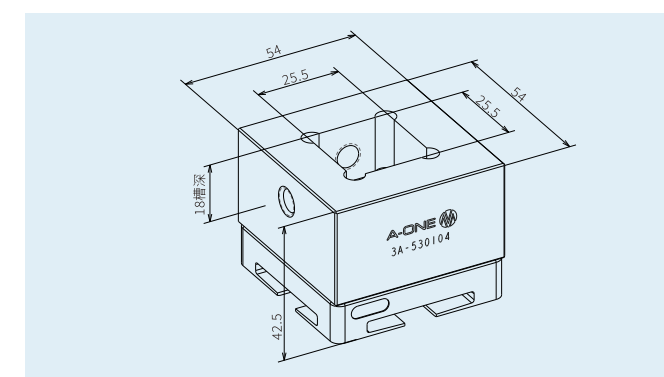

3A-531100 钢电极夹具座
Steel holder

- ▶ 规格 一套12个, 预留安装数据承载器位置。单独订购芯片 3A-400054
- ▶ 备注 定位片需另购
- ▶ Version Set of 12 units, prepared for the installation of the code carrier. Order chip 3A-400054 separately
- ▶ Note Centering plates order separately

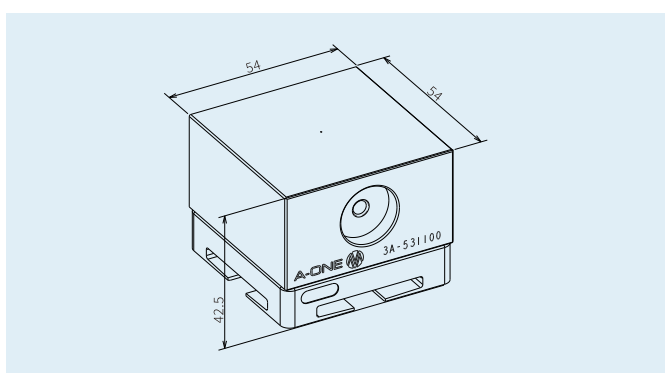

3A-531104 钢电极夹具座
Steel holder

- ▶ 规格 一套12个, 预留安装数据承载器位置。单独订购芯片 3A-400054
- ▶ 备注 定位片需另购
- ▶ Version Set of 12 units, prepared for the installation of the code carrier. Order chip 3A-400054 separately
- ▶ Note Centering plates order separately

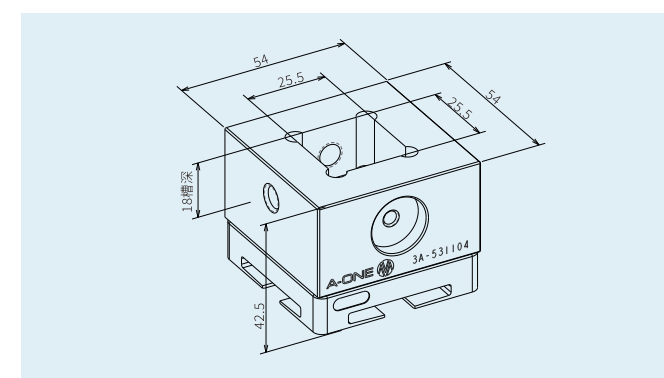

3A-530103 钢电极夹具座
Steel holder

- ▶ 规格 一套12个
- ▶ 应用 用于夹持最大20mm正方形电极或工件
- ▶ 备注 定位片需另购
- ▶ Version Set of 12 units
- ▶ Application For holding the largest 20mm square electrode or workpiece
- ▶ Note Centering plates order separately

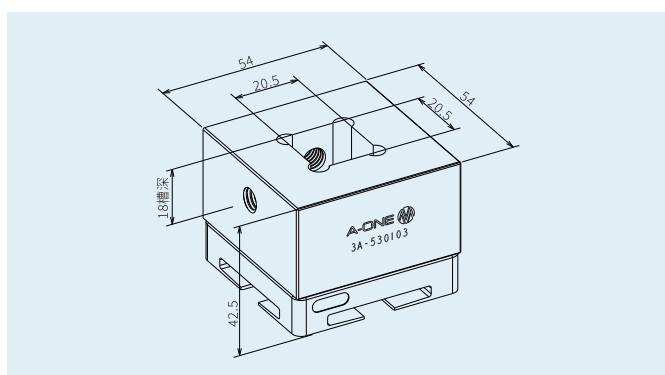

3A-530105 钢电极夹具座
Steel holder

- ▶ 规格 一套12个
- ▶ 应用 用于夹持最大30mm正方形电极或工件
- ▶ 备注 定位片需另购
- ▶ Version Set of 12 units
- ▶ Application For holding the largest 30mm square electrode or workpiece
- ▶ Note Centering plates order separately

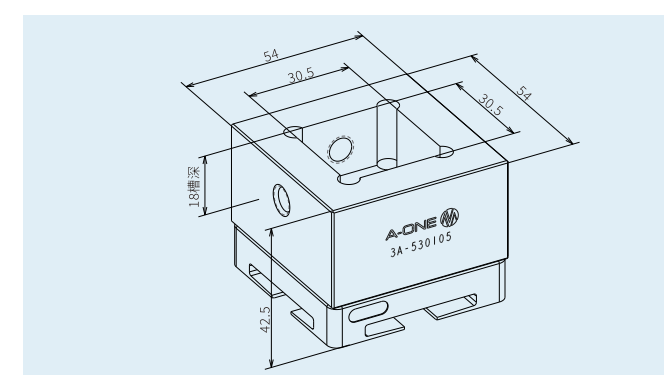

3A-531103 钢电极夹具座
Steel holder

- ▶ 规格 一套12个, 预留安装数据承载器位置。单独订购芯片 3A-400054
- ▶ 备注 定位片需另购
- ▶ Version Set of 12 units, prepared for the installation of the code carrier. Order chip 3A-400054 separately
- ▶ Note Centering plates order separately

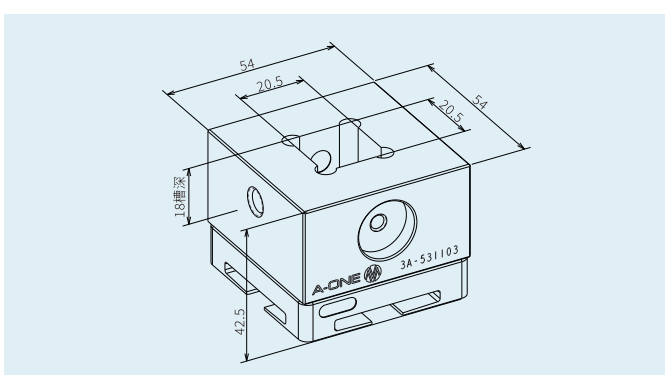

3A-531105 钢电极夹具座
Steel holder

- ▶ 规格 预留安装数据承载器位置。单独订购芯片 3A-400054
- ▶ 备注 定位片需另购
- ▶ Version Prepared for the installation of the code carrier
- ▶ Note Order chip 3A-400054 separately
- ▶ Note Centering plates order separately

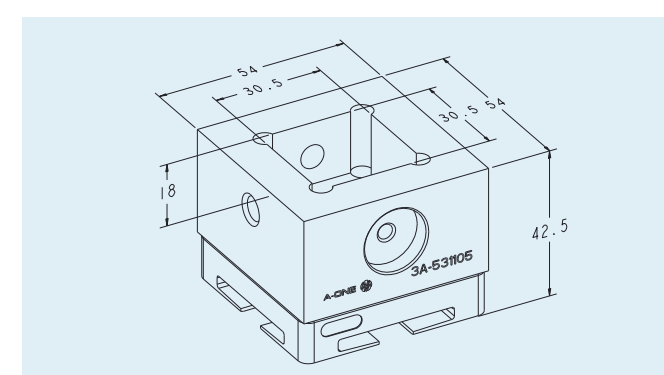

3A-530108 钢电极夹具座
Steel holder

- ▶ 规格 一套12个
- ▶ 应用 用于夹持最大15mm 长方形电极或工件
- ▶ 备注 定位片需另购
- ▶ Version Set of 12 units
- ▶ Application For holding the largest 15mm oblong electrode and workpiece
- ▶ Note Centering plates order separately

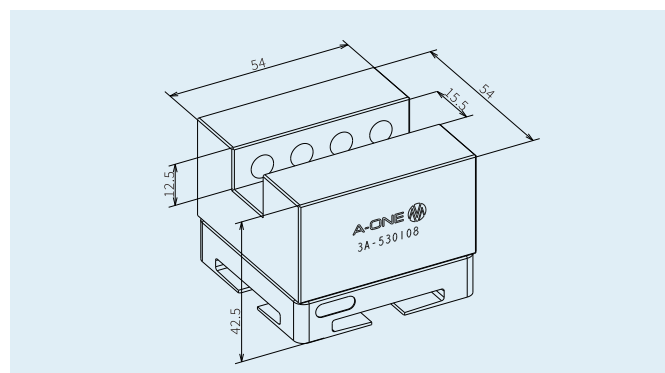

3A-530110 钢电极夹具座
Steel holder

- ▶ 规格 一套12个
- ▶ 应用 用于夹持最大25mm长方形电极或工件
- ▶ 备注 定位片需另购
- ▶ Version Set of 12 units,
- ▶ Application For holding the largest 25mm oblong electrode and workpiece
- ▶ Note Centering plates order separately

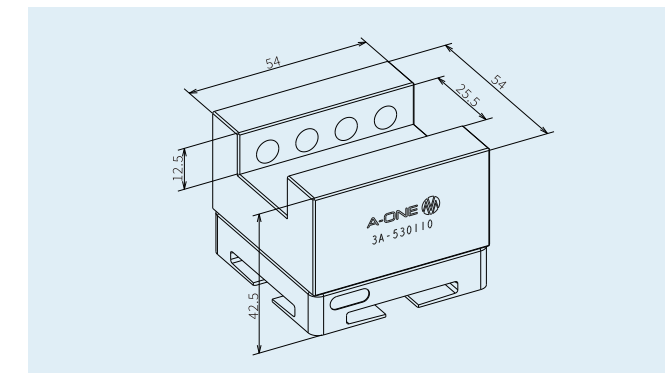

3A-531108 钢电极夹具座
Steel holder

- ▶ 规格 一套12个, 预留安装数据承载器位置。单独订购芯片3A-400054
- ▶ 备注 定位片需另购
- ▶ Version Set of 12 units, prepared for the installation of the code carrier. Order chip 3A-400054 separately
- ▶ Note Centering plates order separately

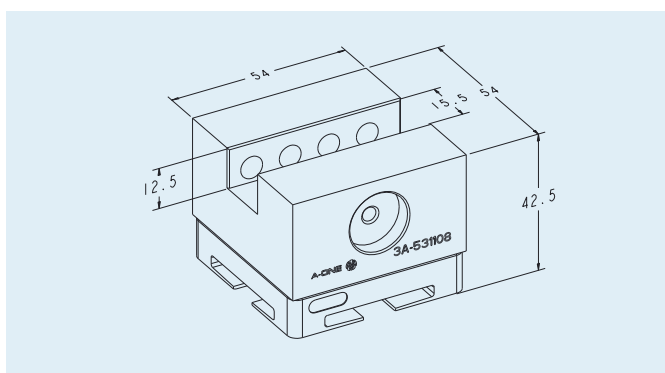

3A-531110 钢电极夹具座
Steel holder

- ▶ 规格 预留安装数据承载器位置。单独订购芯片3A-400054
- ▶ 备注 定位片需另购
- ▶ Version Prepared for the installation of the code carrier. Order chip 3A-400054 separately
- ▶ Note Centering plates order separately

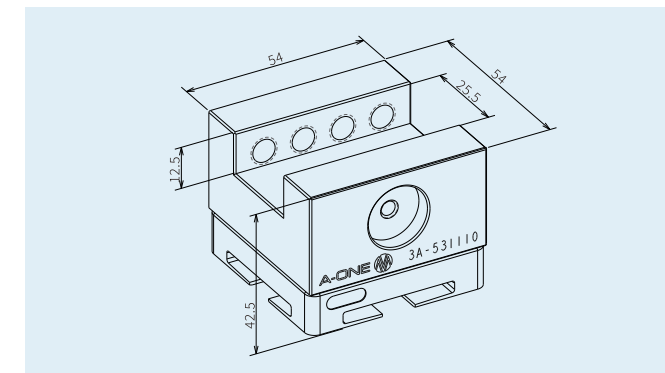

3A-530109 钢电极夹具座
Steel holder

- ▶ 规格 一套12个
- ▶ 应用 用于夹持最大20mm 长方形电极或工件
- ▶ 备注 定位片需另购
- ▶ Version Set of 12 units
- ▶ Application For holding the largest 15mm oblong electrode and workpiece
- ▶ Note Centering plates order separately

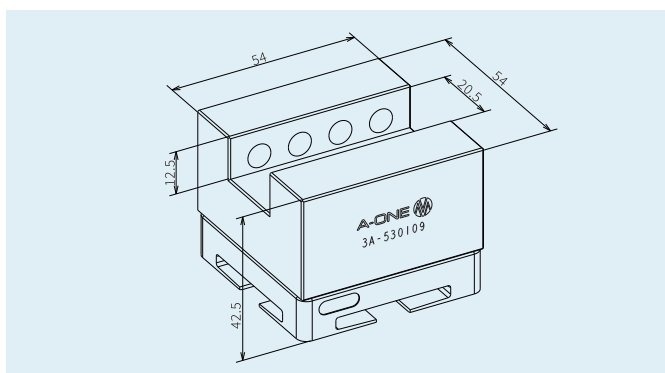

3A-530115 钢电极夹具座
Steel holder

- ▶ 规格 一套12个
- ▶ 应用 用于夹持最大30mm长方形电极或工件
- ▶ 备注 定位片需另购
- ▶ Version Set of 12 units
- ▶ Application For holding the largest 30mm oblong electrode and workpiece
- ▶ Note Centering plates order separately

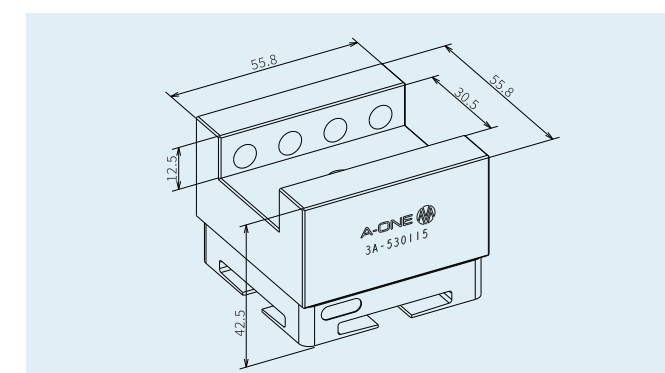

3A-531109 钢电极夹具座
Steel holder

- ▶ 规格 一套12个, 预留安装数据承载器位置。单独订购芯片3A-400054
- ▶ 备注 定位片需另购
- ▶ Version Set of 12 units, prepared for the installation of the code carrier. Order chip 3A-400054 separately
- ▶ Note Centering plates order separately

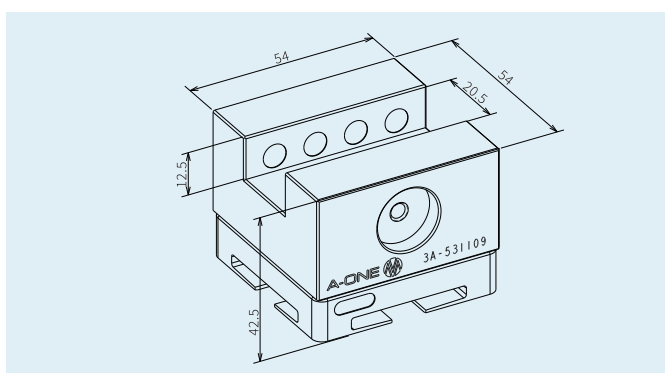

3A-531115 钢电极夹具座
Steel holder

- ▶ 规格 预留安装数据承载器位置。单独订购芯片3A-400054
- ▶ 备注 定位片需另购
- ▶ Version Prepared for the installation of the code carrier. Order chip 3A-400054 separately
- ▶ Note Centering plates order separately

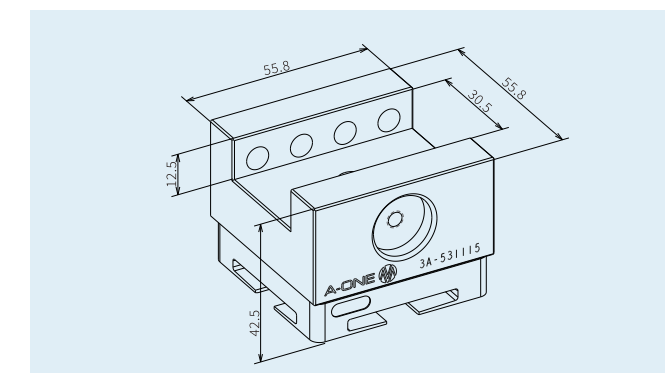

标准电极夹具座(钢)
Standard electrode holder(steel)

标准电极夹具座(铜)
Standard electrode holder(brass)

3A-530116 钢电极夹具座
Steel holder

- ▶ 规格 一套12个
- ▶ 应用 用于夹持最大35mm长方形电极或工件
- ▶ 备注 定位片需另购
- ▶ Version Set of 12 units
- ▶ Application For holding the largest 35mm oblong electrode and workpiece
- ▶ Note Centering plates order separately

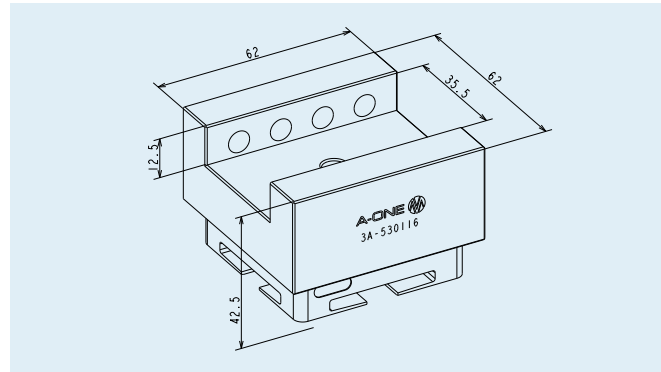

3A-540100 铜电极夹具座
Uniblank

- ▶ 规格 一套12个, 主体未加工
- ▶ 应用 安装各种形状的电极和工件
- ▶ 备注 定位片需另购
- ▶ Version Set of 12 units, fitted without machining of body
- ▶ Application To mount electrodes and workpieces of various shapes
- ▶ Note Centering plates order separately

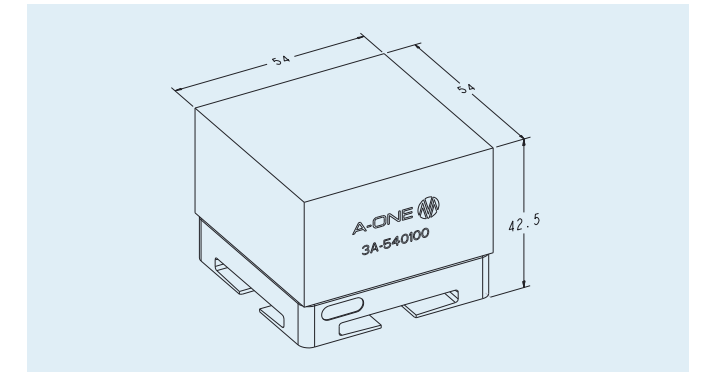

3A-531116 钢电极夹具座
Steel holder

- ▶ 规格 预留安装数据承载器位置。单独订购芯片 3A-400054
- ▶ 备注 定位片需另购
- ▶ Version Prepared for the installation of the code carrier
- ▶ Note Order chip 3A-400054 separately
- ▶ Note Centering plates order separately

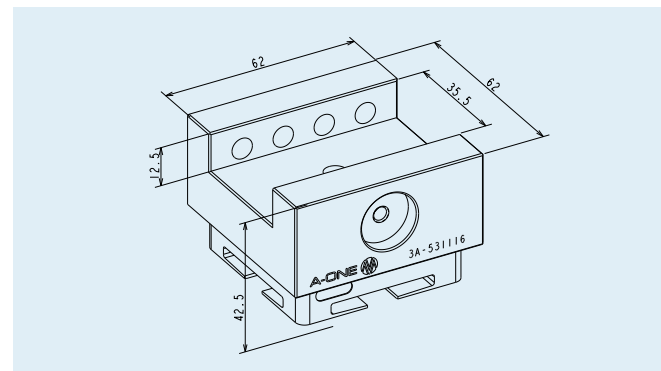

3A-541100 铜电极夹具座
Uniblank

- ▶ 规格 一套12个, 预留安装数据承载器位置。单独订购芯片 3A-400054
- ▶ 备注 定位片需另购
- ▶ Version Set of 12 units, prepared for the installation of the code carrier.
- ▶ Note Order chip 3A-400054 separately
- ▶ Note Centering plates order separately

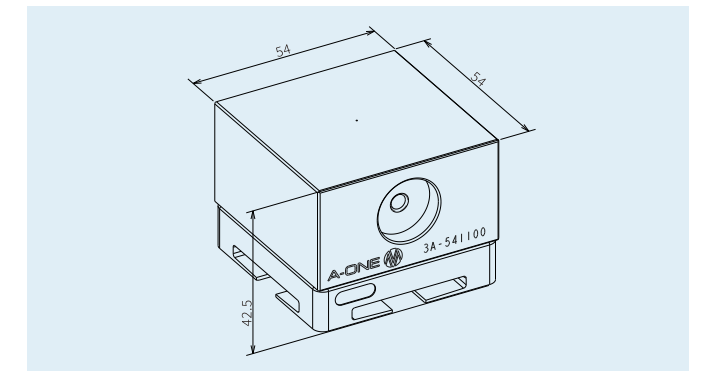

3A-530123 钢电极夹具座
Steel holder

- ▶ 规格 50.8 x 50.8mm 表面平
- ▶ 应用 安装基准表面大于50mm的电极或工件
- ▶ 备注 定位片需另购
- ▶ Version 50.8x50.8 surface
- ▶ Application To mount electrodes and workpieces with shaft sizes of up to 50mm
- ▶ Note Centering plates order separately

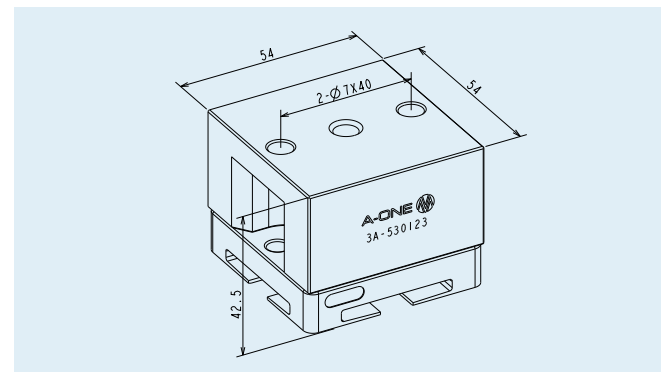

3A-540103 铜电极夹具座
Uniblank

- ▶ 规格 一套12个
- ▶ 应用 用于夹持最大20mm正方形电极或工件
- ▶ 备注 定位片需另购
- ▶ Version Set of 12 units
- ▶ Application For holding the largest 20mm square electrode or workpiece
- ▶ Note Centering plates order separately

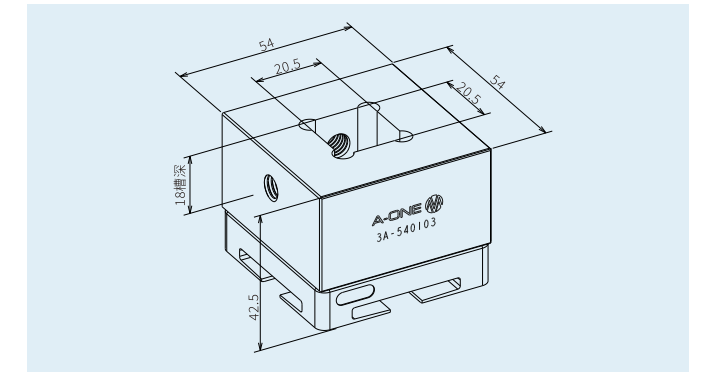

3A-531123 钢电极夹具座
Steel holder

- ▶ 规格 预留安装数据承载器位置。单独订购芯片 3A-400054
- ▶ 备注 定位片需另购
- ▶ Version Prepared for the installation of the code carrier
- ▶ Note Order chip 3A-400054 separately
- ▶ Note Centering plates order separately

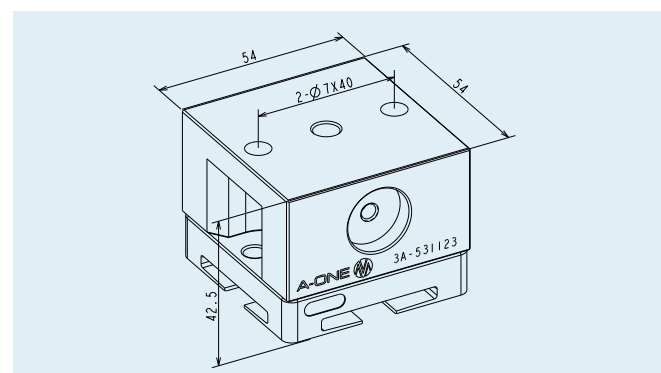

3A-541103 铜电极夹具座
Prisround

- ▶ 规格 一套12个, 预留安装数据承载器位置。单独订购芯片 3A-400054
- ▶ 备注 定位片需另购
- ▶ Version Set of 12 units, prepared for the installation of the code carrier.
- ▶ Note Order chip 3A-400054 separately
- ▶ Note Centering plates order separately

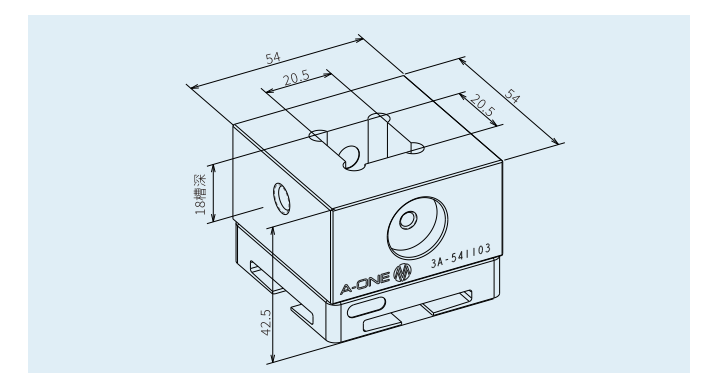

3A-540104 铜电极夹具座
Prisround

- ▶ 规格 一套12个
- ▶ 应用 用于夹持最大25mm 正方形电极或工件
- ▶ 备注 定位片需另购
- ▶ Version Set of 12 units
- ▶ Version For holding the largest 25mm square electrode or workpiece
- ▶ Note Centering plates order separately

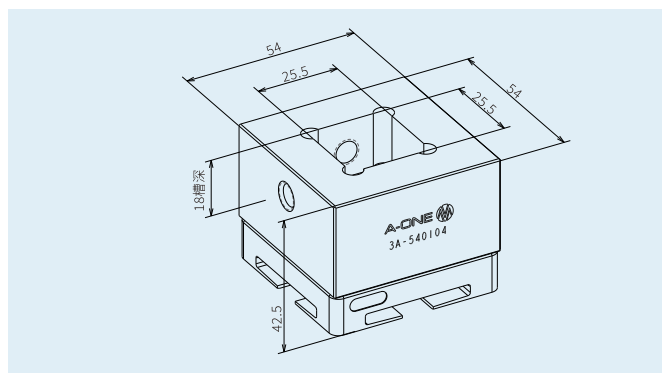

3A-540108 铜电极夹具座
Uniholder

- ▶ 规格 一套12个
- ▶ 应用 用于夹持最大15mm 长方形电极或工件
- ▶ 备注 定位片需另购
- ▶ Version Set of 12 units
- ▶ Application For holding the largest 15mm oblong electrode and workpiece
- ▶ Note Centering plates order separately

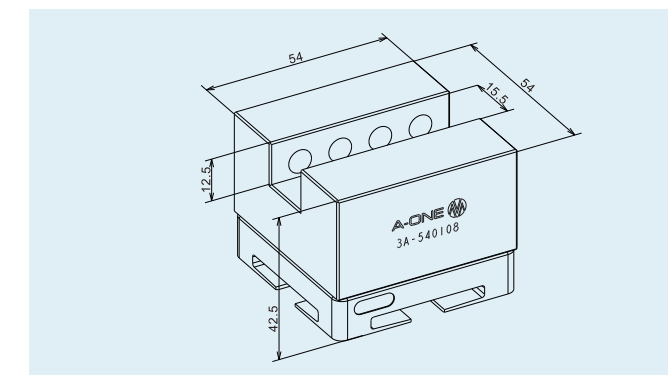

3A-541104 铜电极夹具座
Prisround

- ▶ 规格 一套12个, 预留安装数据承载器位置。单独订购芯片3A-400054
- ▶ 备注 定位片需另购
- ▶ Version Set of 12 units, prepared for the installation of the code carrier. Order chip 3A-400054 separately
- ▶ Note Centering plates order separately

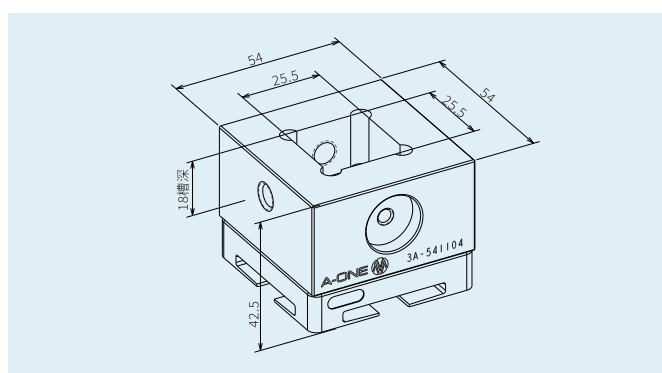

3A-541108 铜电极夹具座
Uniholder

- ▶ 规格 一套12个, 预留安装数据承载器位置。单独订购芯片3A-400054
- ▶ 备注 定位片需另购
- ▶ Version Set of 12 units, prepared for the installation of the code carrier. Order chip 3A-400054 separately
- ▶ Note Centering plates order separately

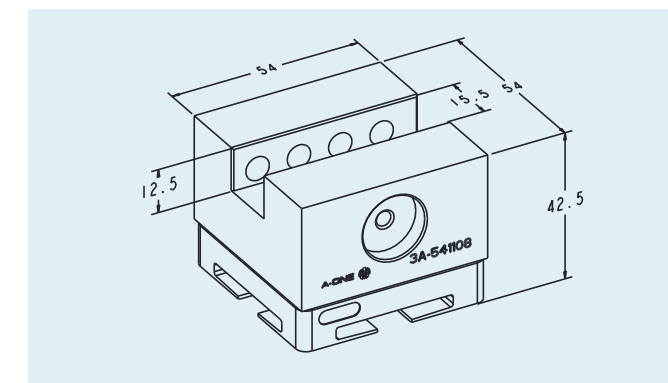

3A-540105 铜电极夹具座
Prisround

- ▶ 规格 一套12个
- ▶ 应用 用于夹持最大30mm 正方形电极或工件
- ▶ 备注 定位片需另购
- ▶ Version Set of 12 units
- ▶ Application For holding the largest 30mm square electrode or workpiece
- ▶ Note Centering plates order separately

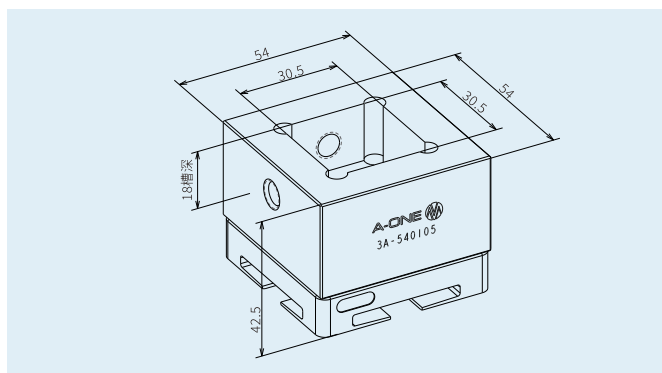

3A-540109 铜电极夹具座
Uniholder

- ▶ 规格 一套12个
- ▶ 应用 用于夹持最大20mm 长方形电极或工件
- ▶ 备注 定位片需另购
- ▶ Version Set of 12 units
- ▶ Application For electrode up to 20 mm oblong electrode and workpiece
- ▶ Note Centering plates order separately

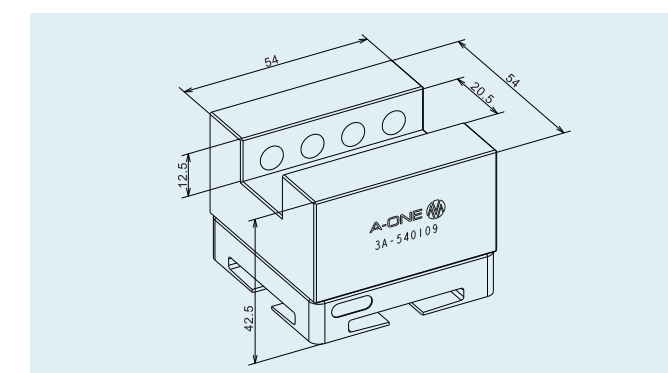

3A-541105 铜电极夹具座
Prisround

- ▶ 规格 预留安装数据承载器位置。单独订购芯片3A-400054
- ▶ 备注 定位片需另购
- ▶ Version Prepared for the installation of the code carrier. Order chip 3A-400054 separately
- ▶ Note Centering plates order separately

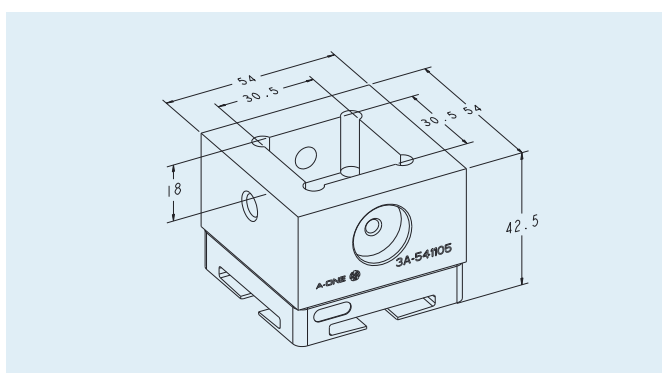

3A-541109 铜电极夹具座
Uniholder

- ▶ 规格 一套12个, 预留安装数据承载器位置。单独订购芯片3A-400054
- ▶ 备注 定位片需另购
- ▶ Version Set of 12 units, prepared for the installation of the code carrier. Order chip 3A-400054 separately
- ▶ Note Centering plates order separately

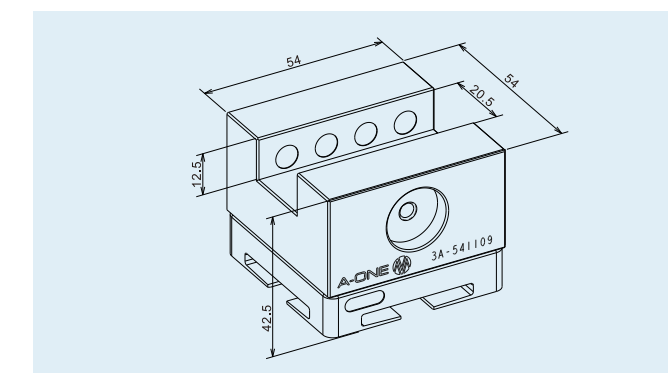

3A-540110 铜电极夹具座
Uniholder

- ▶ 规格 一套12个
- ▶ 应用 用于夹持最大25mm 长方形电极或工件
- ▶ 备注 定位片需另购
- ▶ Version Set of 12 units,
- ▶ Application For holding the largest 25mm oblong electrode and workpiece
- ▶ Note Centering plates order separately

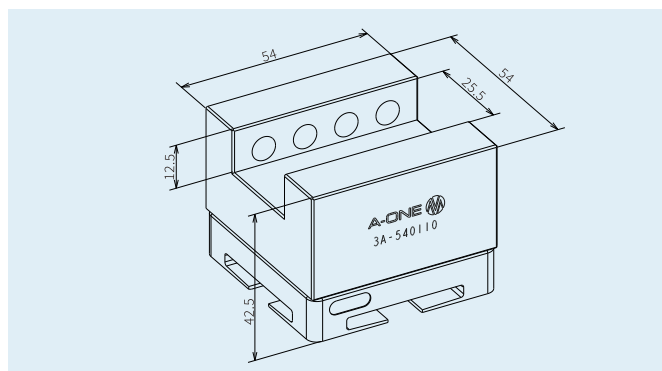

3A-540116 铜电极夹具座
Uniholder

- ▶ 规格 一套12个
- ▶ 应用 用于夹持最大35mm 长方形电极或工件
- ▶ 备注 定位片需另购
- ▶ Version Set of 12 units
- ▶ Application For holding the largest 35mm oblong electrode and workpiece
- ▶ Note Centering plates order separately

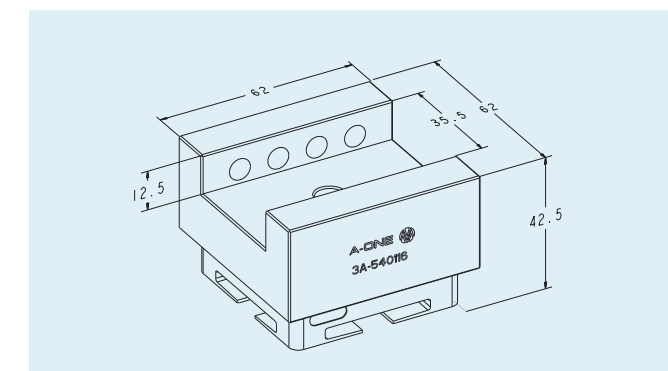

3A-541110 铜电极夹具座
Uniholder

- ▶ 规格 预留安装数据承载器位置。单独订购芯片3A-400054
- ▶ 备注 定位片需另购
- ▶ Version Prepared for the installation of the code carrier.
- ▶ Note Order chip 3A-400054 separately
Centering plates order separately

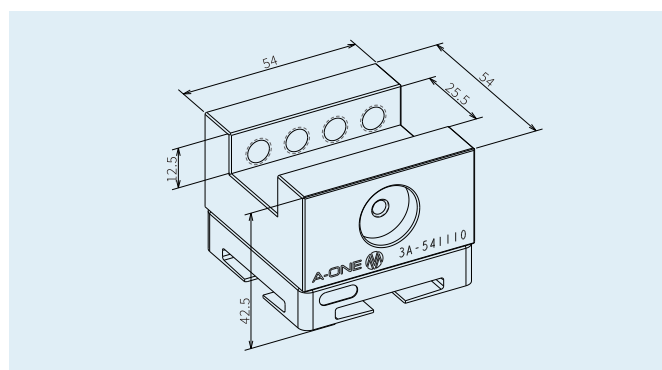

3A-541116 铜电极夹具座
Uniholder

- ▶ 规格 预留安装数据承载器位置。单独订购芯片3A-400054
- ▶ 备注 定位片需另购
- ▶ Version Prepared for the installation of the code carrier
- ▶ Note Order chip 3A-400054 separately
Centering plates order separately

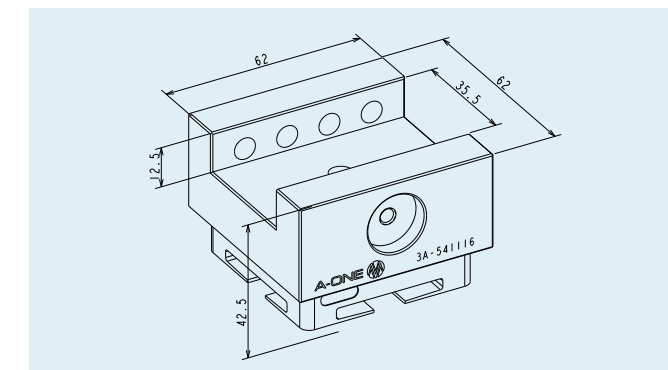

3A-540115 铜电极夹具座
Uniholder

- ▶ 规格 一套12个
- ▶ 应用 用于夹持最大30mm 长方形电极或工件
- ▶ 备注 定位片需另购
- ▶ Version Set of 12 units
- ▶ Application For holding the largest 30mm oblong electrode and workpiece
- ▶ Note Centering plates order separately

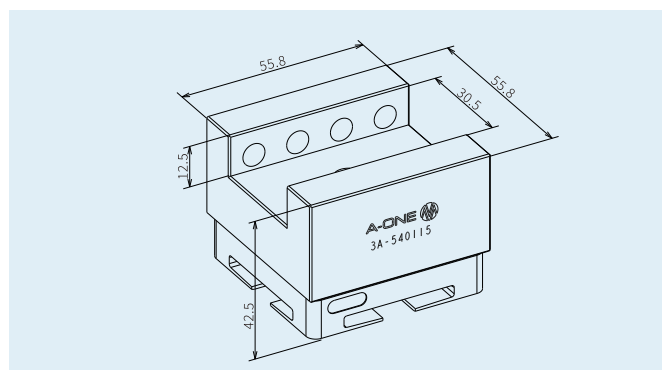

3A-540123 铜电极夹具座
Uniplate

- ▶ 规格 50.8 x 50.8mm 表面平
- ▶ 应用 安装基准表面大于50mm 的电极或工件
- ▶ 备注 定位片需另购
- ▶ Version 50.8x50.8mm surface
- ▶ Application To mount electrodes and workpieces with shaft sizes of up to 50mm
- ▶ Note Centering plates order separately

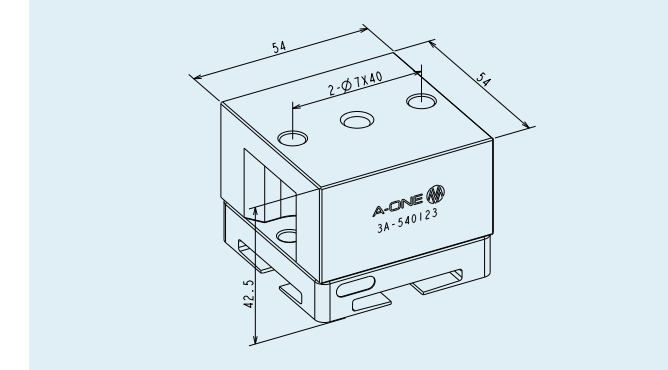

3A-541115 铜电极夹具座
Uniholder

- ▶ 规格 预留安装数据承载器位置。单独订购芯片3A-400054
- ▶ 备注 定位片需另购
- ▶ Version Prepared for the installation of the code carrier.
- ▶ Note Order chip 3A-400054 separately
Centering plates order separately

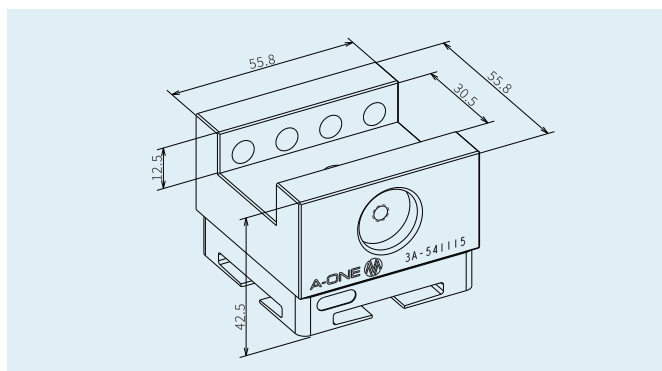

3A-541123 铜电极夹具座
Uniplate

- ▶ 规格 预留安装数据承载器位置。单独订购芯片3A-400054
- ▶ 备注 定位片需另购
- ▶ Version Prepared for the installation of the code carrier.
- ▶ Note Order chip 3A-400054 separately
Centering plates order separately

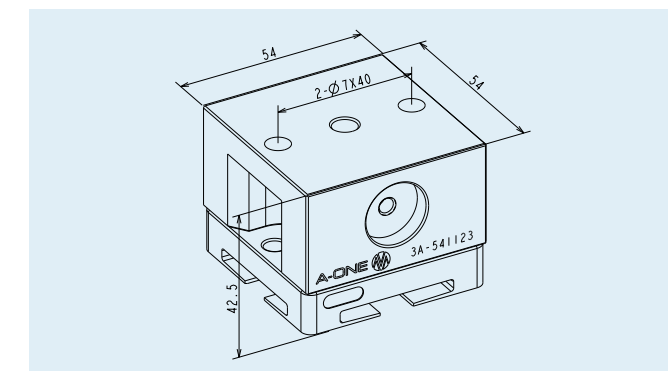

3A-300099 R 型筒式夹头
R Collet Chuck Holder

- ▶ 规格 适用筒夹 ER32
- ▶ 应用 电极尺寸 $\varnothing 2-20\text{mm}$
- ▶ 注意 筒夹需另购
- ▶ Version Suited for ER32 collet chuck
- ▶ Application For electrode up to $\varnothing 2-20\text{mm}$
- ▶ Note Order collet chuck separately

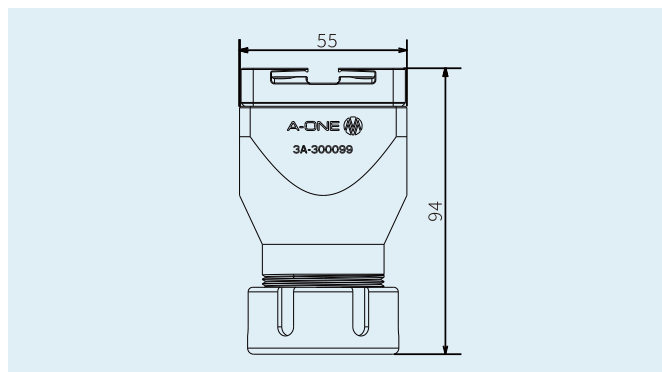

3A-400013 扭力扳手
Torque wrench

- ▶ 规格 扭力可调4-12nm
- ▶ 应用 安装调试3A-400003 定位片 (50型) 脚钉用
- ▶ Version Torque is adjustable 4-12nm
- ▶ Application Can be used when assemble screws in 3A-400003 (50 type) centering plate



3A-400054 带芯片的固定装置H14
Chip with holder

- ▶ 规格 衬套中装有嵌入式数据承载器。电器导线互联系统芯片: 只读
- ▶ 应用 应用于任何预先准备放置芯片的A-ONE电极夹头和托板扫描器另购
- ▶ 注意
- ▶ Version Sleeve fitting with built-in datacarrier. Rapid chip: read only.
- ▶ Application In any A-ONE electrode holder and pallet which has been prepared for it
- ▶ Note Scan machine order separately

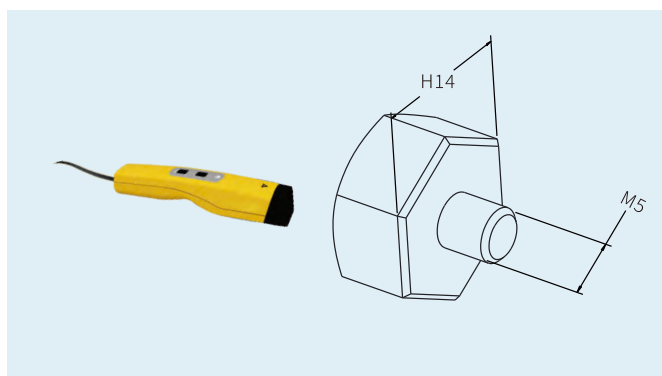

3A-300107 黑、红、蓝色电极储存胶盒
Electrode storage box (Black/Red/Blue)

- ▶ 规格 内置尺寸为54.7x54.7mm, 产品适用于50型电极座存放, 一款可放15个
- ▶ 应用
- ▶ Version Inside size: 54.7x54.7mm, Can be used to storage 50 type electrode holders, One can put 15 pieces
- ▶ Note

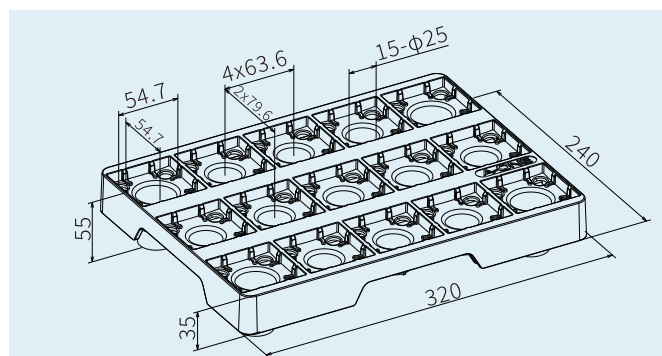

3A-300054 R 型EDM 零位基准
R type EDM Sensor with ball D $\varnothing 6$

- ▶ 应用 适用于EDM电火花机成型, 工件或电极基准零位的找正
- ▶ Application To be used on zero point correction for EDM, workpiece or electrode

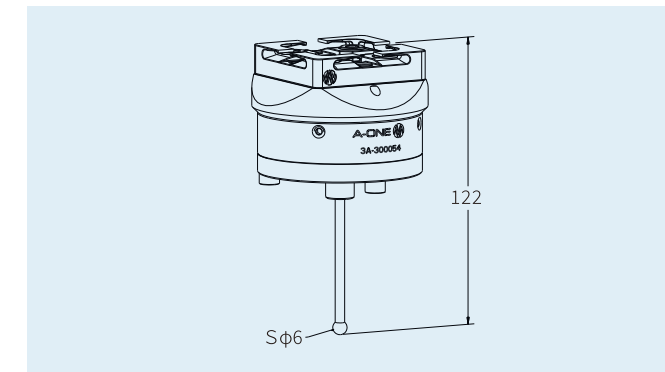

3A-100056 R 型检测杆
R type Checking pin

- ▶ 规格 测量长度110mm
- ▶ 应用 适用于R型卡盘的校正和检测
- ▶ 基准 X、Y 外圆及中心孔
- ▶ Version Measuring length up to 110mm
- ▶ Application Alignment and measurement of R type chuck
- ▶ Benchmark X、Y axis ,cylindrical and center hole

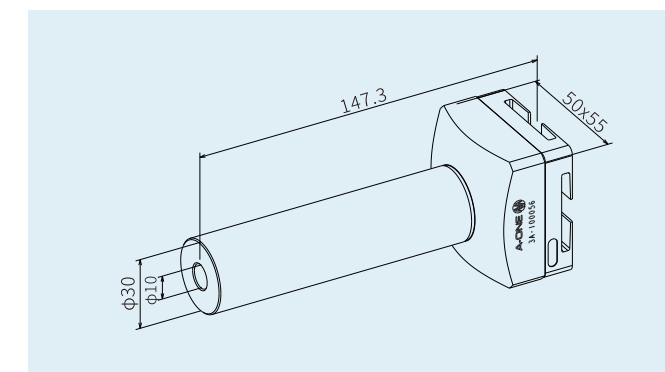

3A-100075 R型平直规
R type flat calibration gauge

- ▶ 应用 用于卡盘X、Y、Z方向平行检测, 校正
- ▶ Application Used for detection and correction of parallel X、Y and Z directions of the chuck

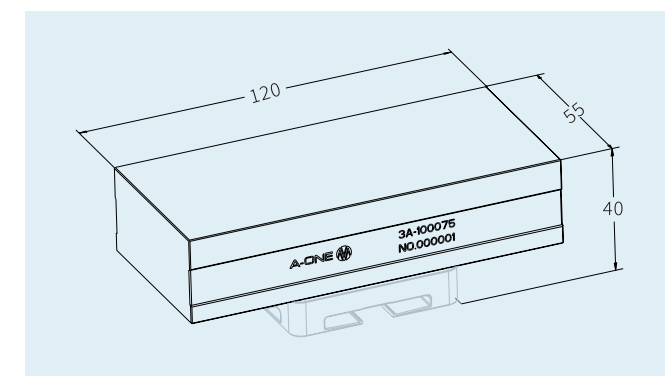

3A-300027 R 型校正规
R alignment rail

- ▶ 规格 测量长度为50mm
- ▶ 应用 用于调整角位, 磨削外径做中心调整之用
- ▶ Version Measuring length 50mm
- ▶ Application Used to adjust angle, grinding outside diameter for center adjustment

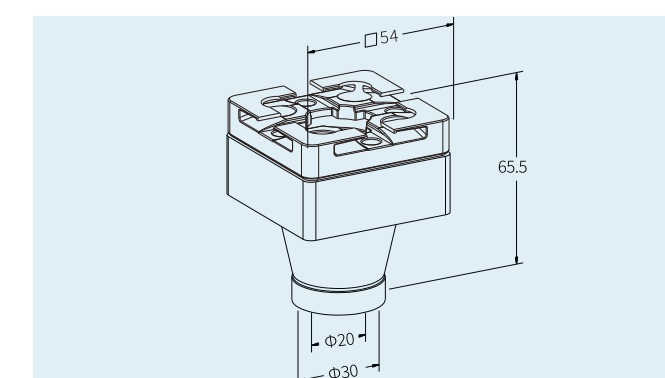

部分合作伙伴 (排序不分先后)

Partial partner

模具加工 Mold processing

- | | | | | |
|--------|--------|-------|--------|------|
| | | | | |
| 宝利根 | 宝田精工 | 比亚迪 | 常州华威模具 | 大豪车业 |
| | | | | |
| 大连釜艺精密 | 得意电子 | 德丰电创 | 东菱 | 东泰精密 |
| | | | | |
| 凤铝 | 富士康集团 | 广东长盈 | 赫比 | 恒德 |
| | | | | |
| 宏丰 | 金莱特 | 金三维 | 精英模具 | 九江金鹭 |
| | | | | |
| 九牧厨卫 | 莱克 | 理光 | 立讯精密工业 | 领益 |
| | | | | |
| 绿点科技 | 南平铝业 | 宁波华德 | 宁波继峰 | 宁波均胜 |
| | | | | |
| 普联 | 群创光电 | 厦门华尔达 | 山东豪迈 | 上海瀚氏 |
| | | | | |
| 深圳凯中精密 | 伟康医疗 | 香港模具 | 烟台霍富 | 亿和 |
| | | | | |
| 银宝山新 | 珠海格力大金 | 珠海三威 | 华益盛 | 海泰科 |

口碑好, 20多年经验积累

Good word of mouth , More than 20 years of experience

凭借品质稳定、性价比高, 得到海内外客户的高度肯定。

Thanks to its stable quality and high cost performance, it is highly recognized by customers at home and abroad.



零件加工 Parts processing

- | | | | | |
|-----------|------|-----------|--------|--------|
| | | | | |
| ASM先进半导体 | TTI | 北方自动控制研究所 | 彼联科技 | 伯恩光学 |
| | | | | |
| 潮州三环 | 大博医疗 | 东莞祥鑫 | 国泰达鸣精密 | 杭州西子航空 |
| | | | | |
| 恒拓高 | 华生电机 | 利元亨 | 南京造币厂 | 南兴木工 |
| | | | | |
| 锐健 | 瑞声科技 | 上海航天 | 一汽大众 | 中船重工 |
| | | | | |
| 中国工程物理研究院 | 中均科技 | 中山科瑞 | 迈瑞 | 深圳吉阳 |

其他 Other

- | | | | | | |
|--------|----|------|------|-----|-------|
| | | | | | |
| 北京精雕集团 | 牧野 | 航天壹巨 | 庆鸿机电 | 沙迪克 | 株洲科力特 |